

PROGETTO DI ALLESTIMENTO DELLA MOSTRA

"Viaggio attraverso i giardini d'Europa
da André Le Nôtre a Henry James"

PIANO PRIMO SALE DELLE ARTI

OGGETTO: ELABORATI GRAFICI

DATA: 03/2019

RESPONSABILE DEL PROCEDIMENTO:

Arch. Francesco Bosso

PROGETTO DI ALLESTIMENTO

Arch. Maurizio Reggi (Coord.)
Arch. Diego Bernardi

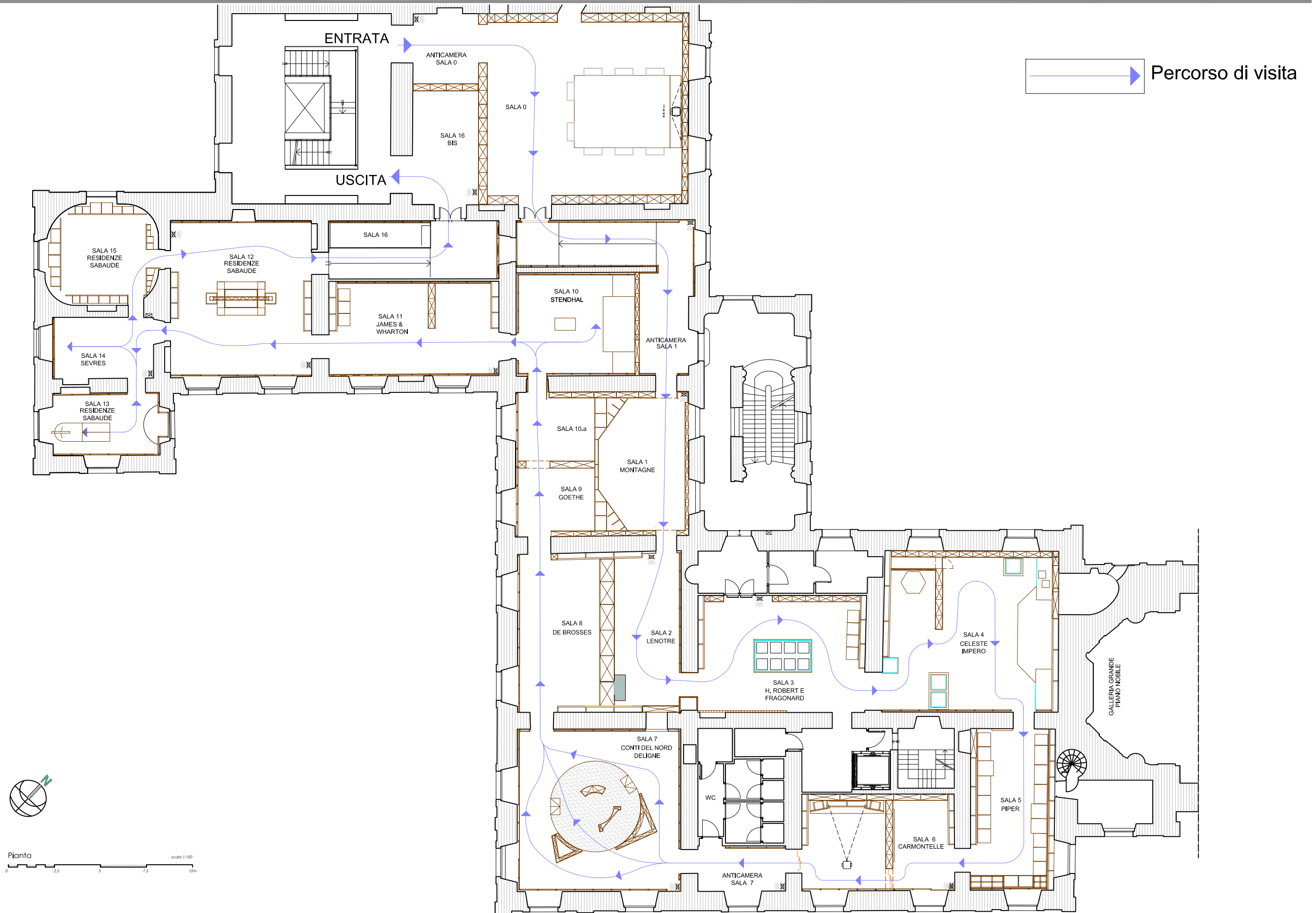

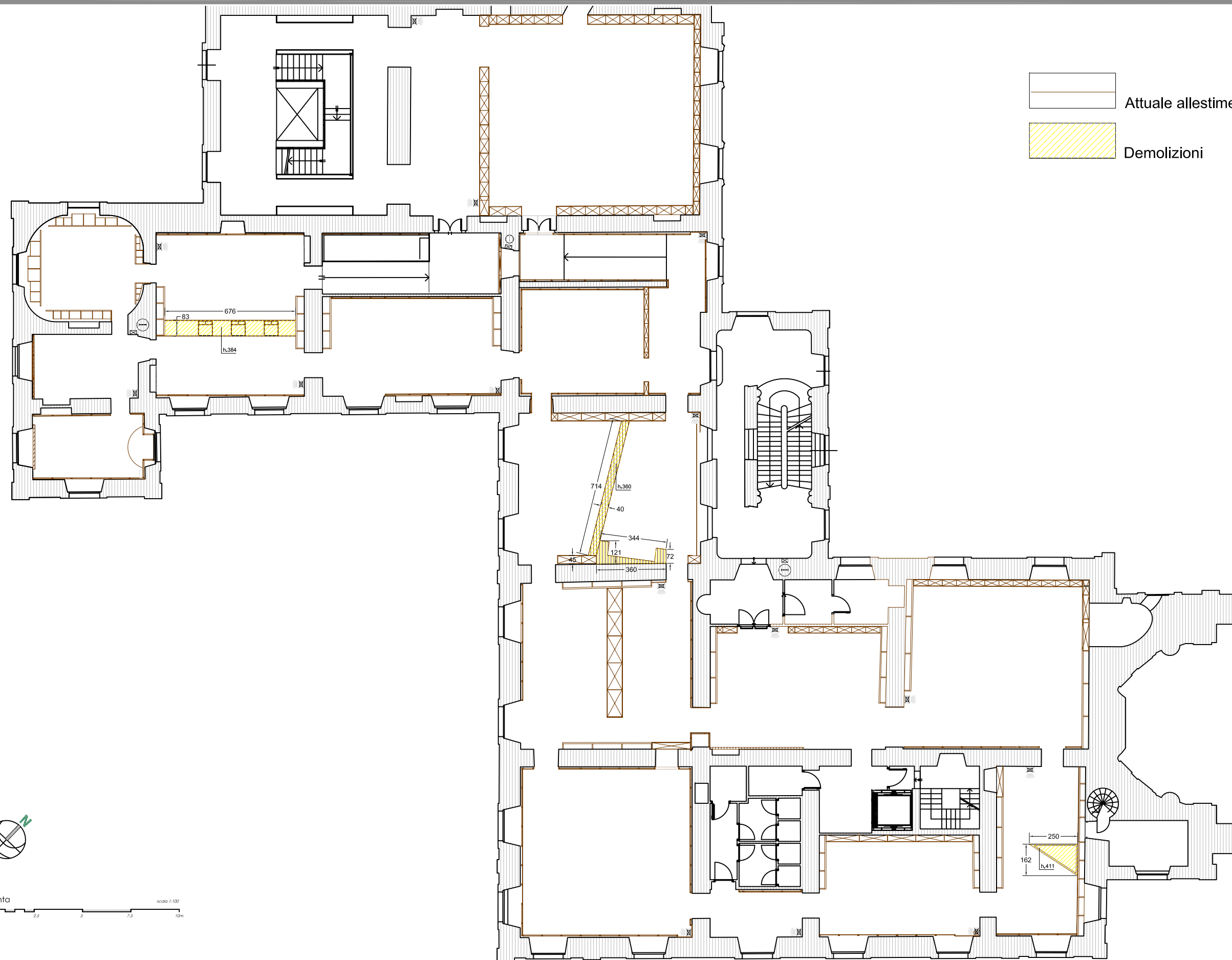



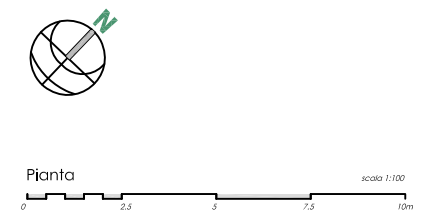

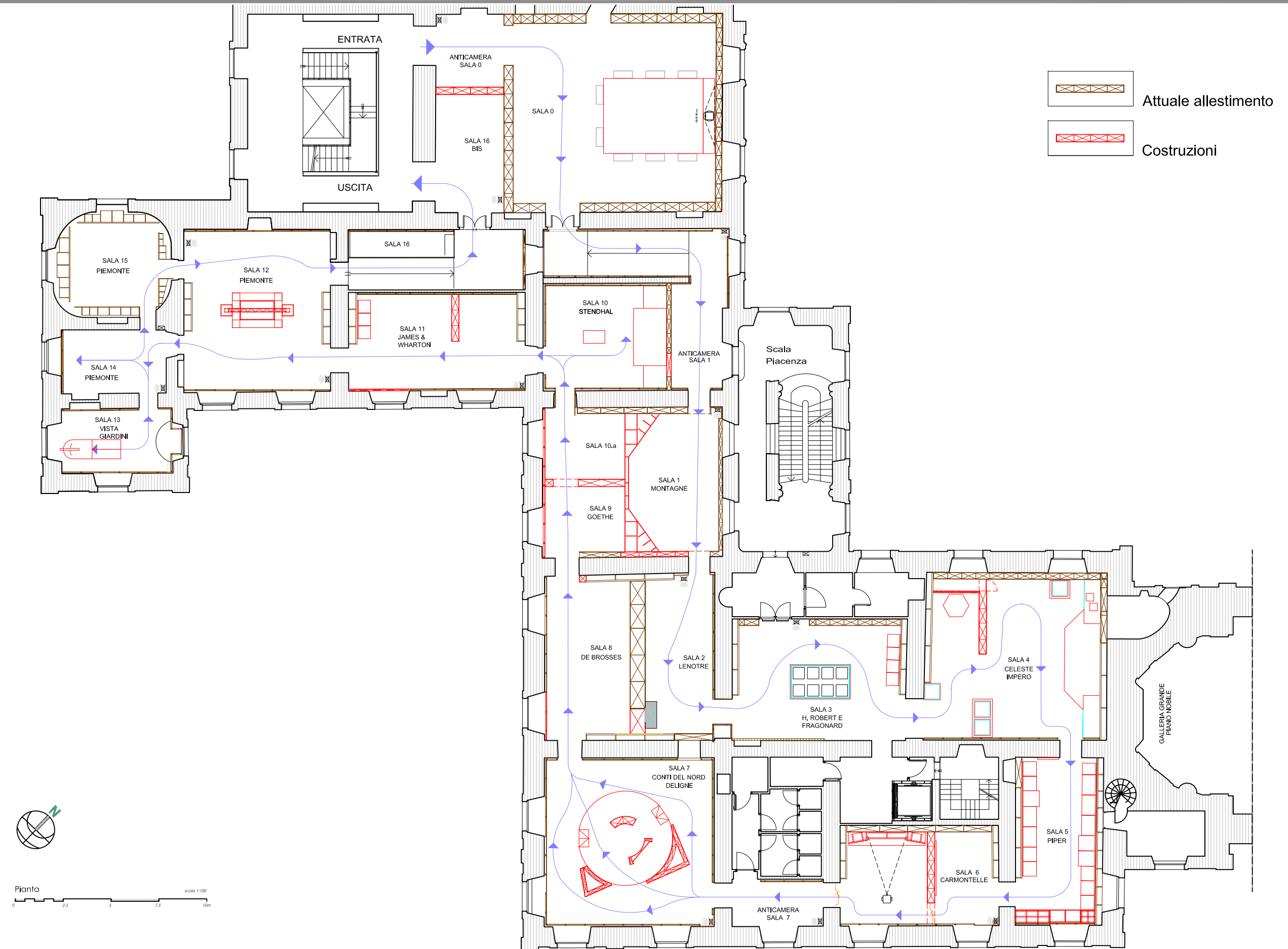

Attuale allestimento
Demolizioni











IMPIANTI ESISTENTI

-  Piantana
-  Binari a soffitto per illuminazione
-  Binari Halfen utilizzati nell'allestimento
-  Ventilconvettori
-  Proiezioni travi solai
-  Idrante

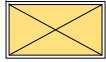
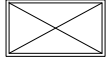
CODICI ELEMENTI IN APPALTO

- Sn.M0n Moli esistenti e nuovi
- Sn.G0n Grafica: pellicola in PVC
- Sn.C0n Grafica: Canvas sparapuntati
- Sn.B0n Grafica: teli in PVC
- Sn.F0n Grafica: pannelli sandwich piuma
- Sn.P0n Grafica: prespaziati
- Sn.V0n Vettrine/Bacheche
- Sn.S0n Specchi e vetri
- Sn.T0n Tende
- Sn.TV0n monitor/televisori/videoproiettori
- Sn.AV0n arredi vari

RAPPRESENTAZIONE GRAFICA ELEMENTI IN APPALTO

-  Moli esistenti
-  Moli nuova fornitura
-  Grafica: pellicola su molo
-  Grafica: canvas
-  Grafica: pannelli in piuma
-  Grafica: prespaziati
-  Opere

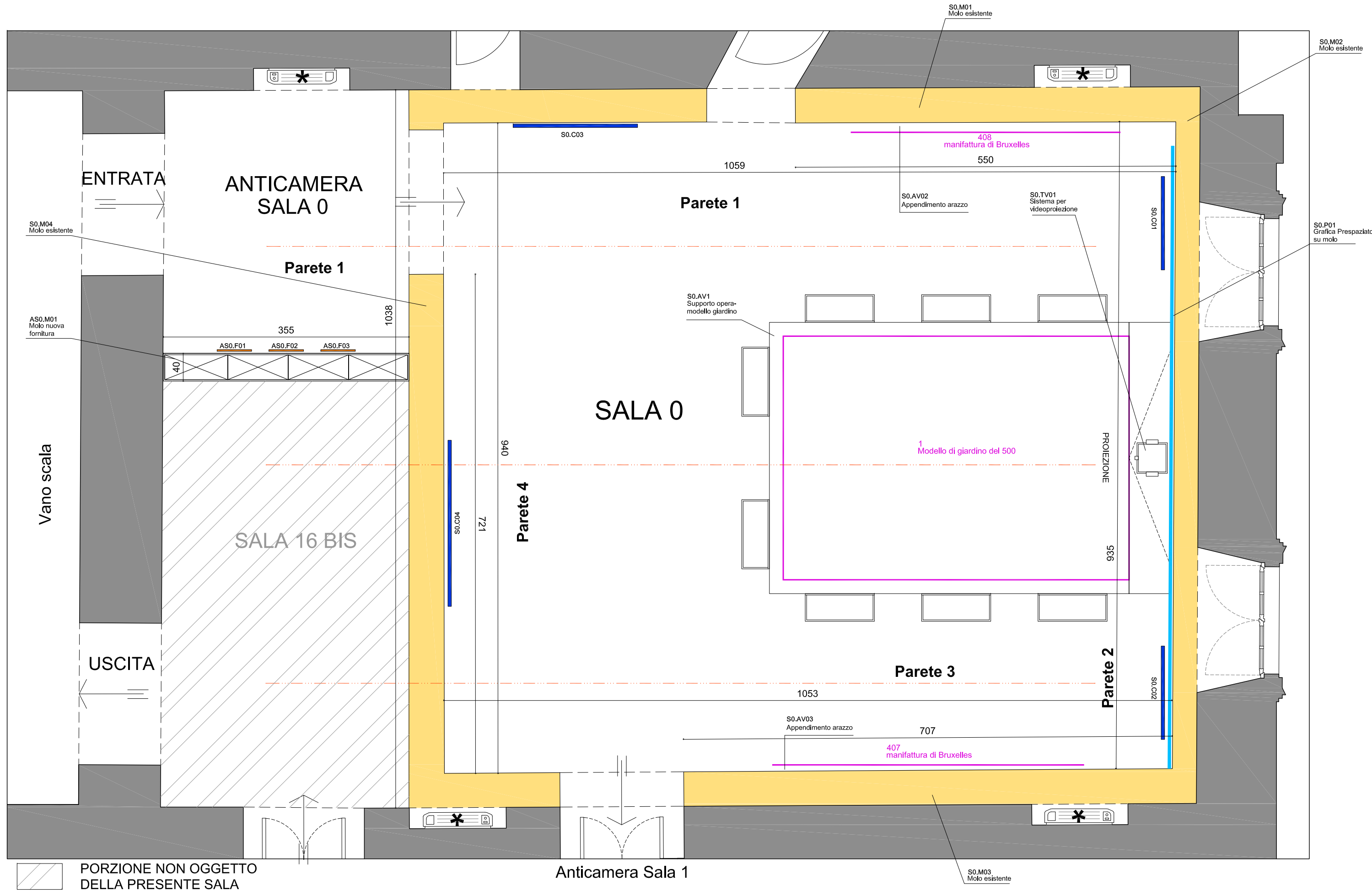

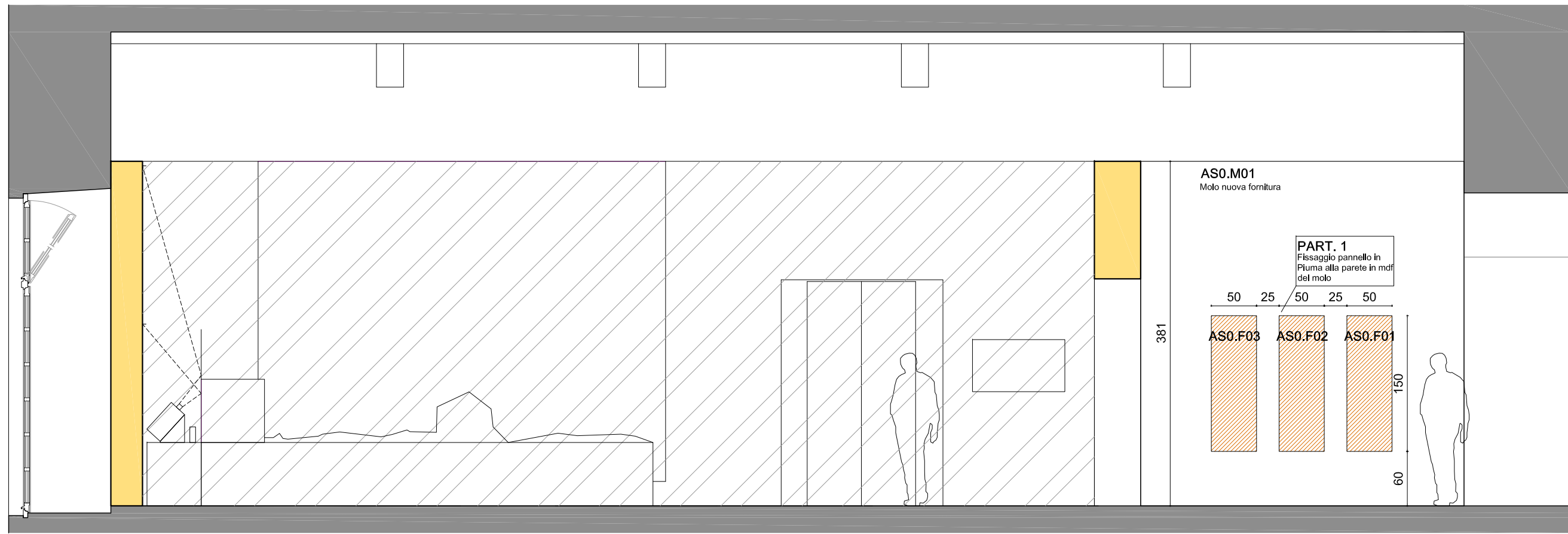

Parete 1

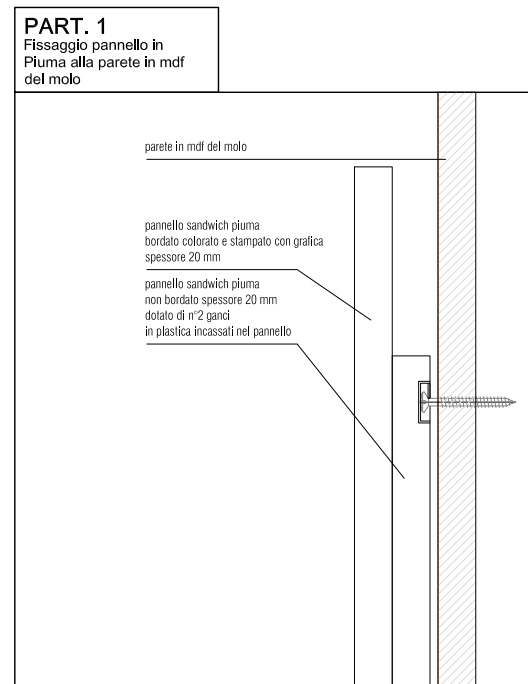

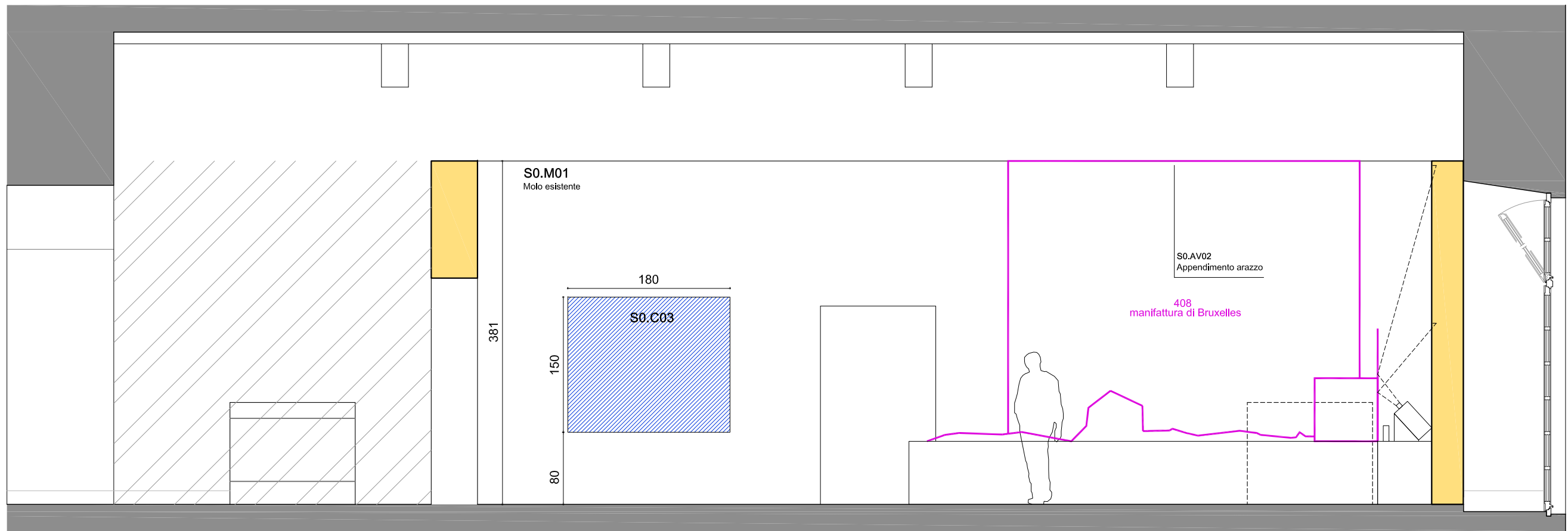

Parete 1

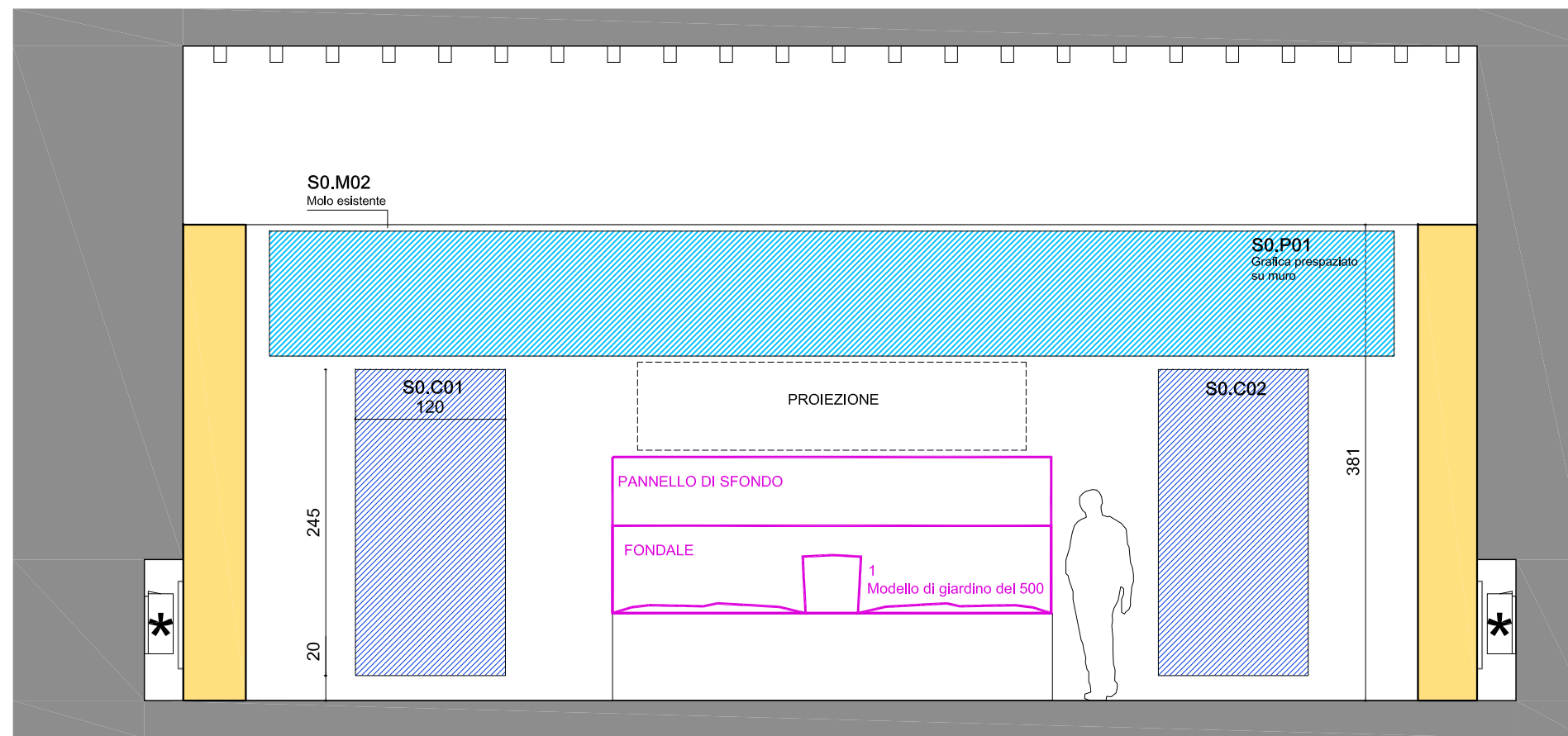

Parete 2

 PORZIONE NON OGGETTO DELLA PRESENTE SALA

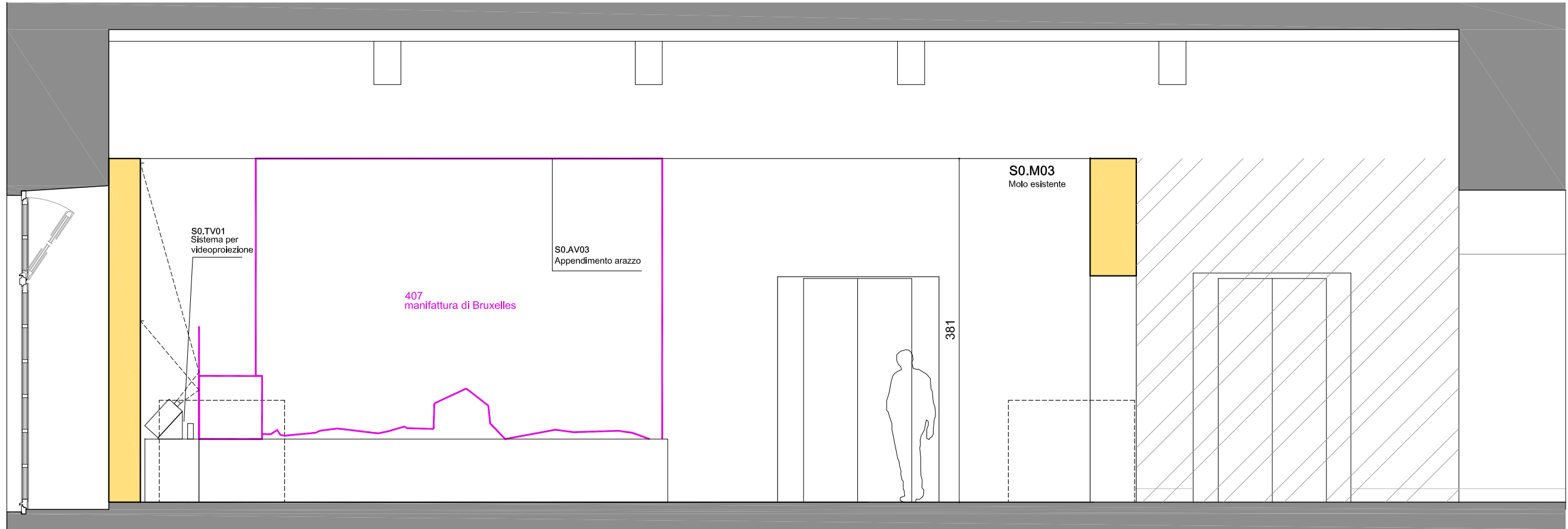

Parete 3

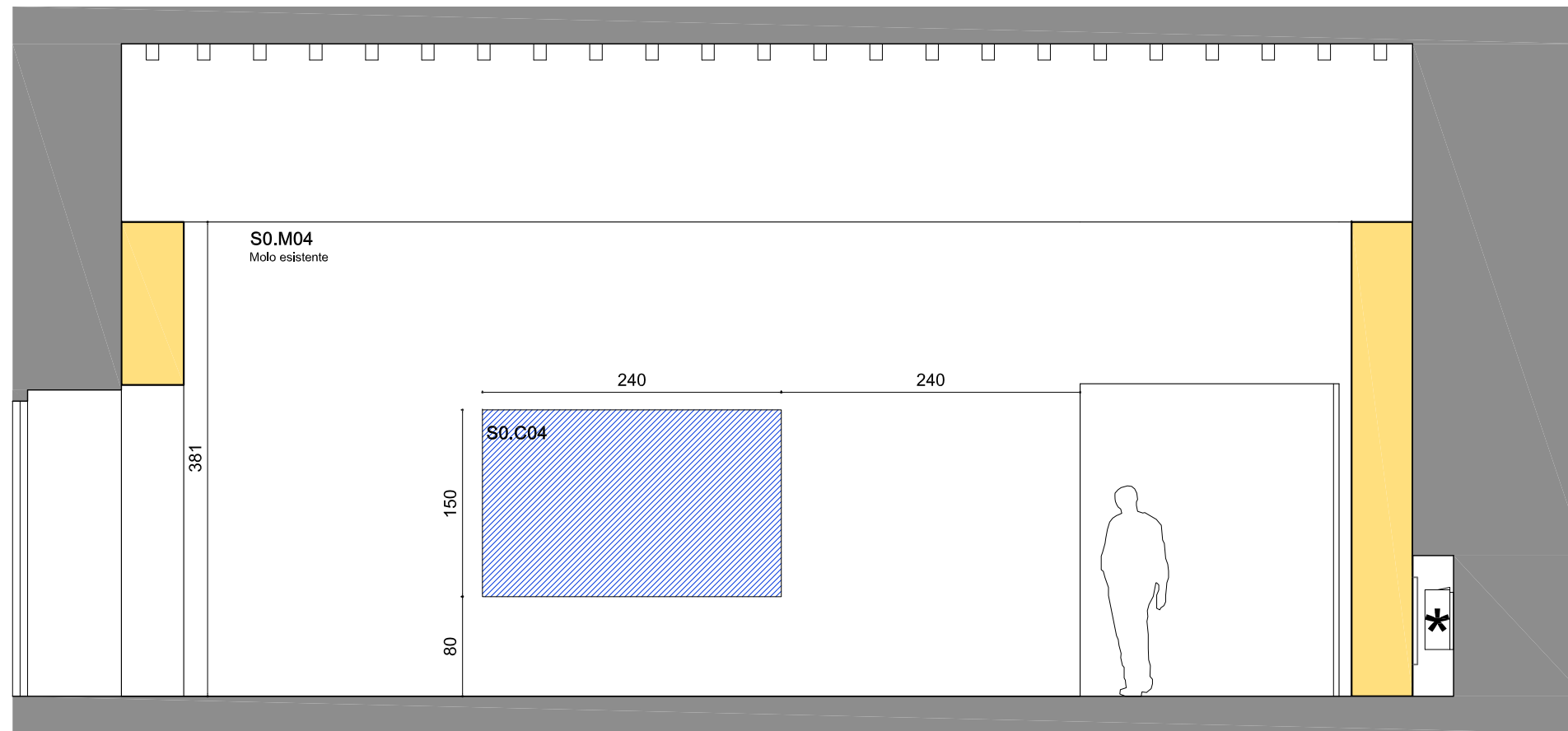

Parete 4

 PORZIONE NON OGGETTO DELLA PRESENTE SALA

S0.AV1
Supporto opera-
modello giardino

PART. 1
finitura pedana modello giardino

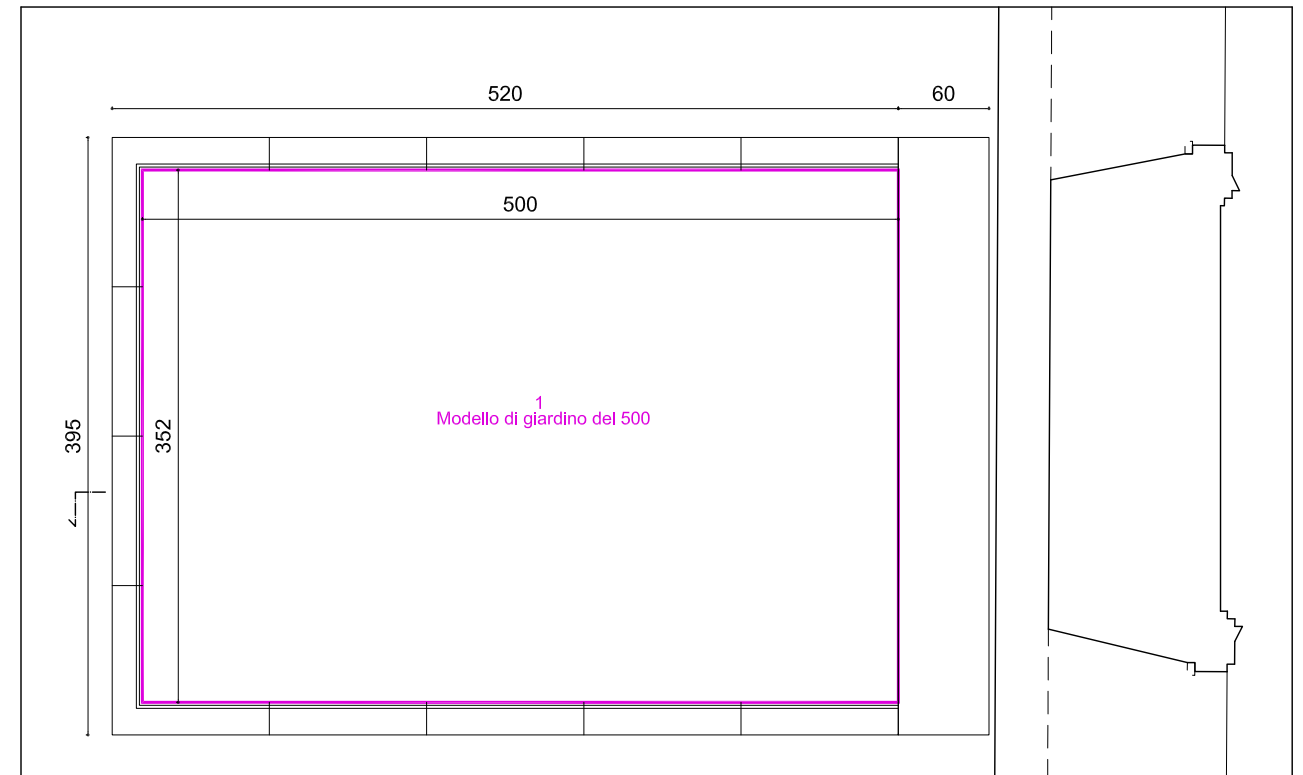
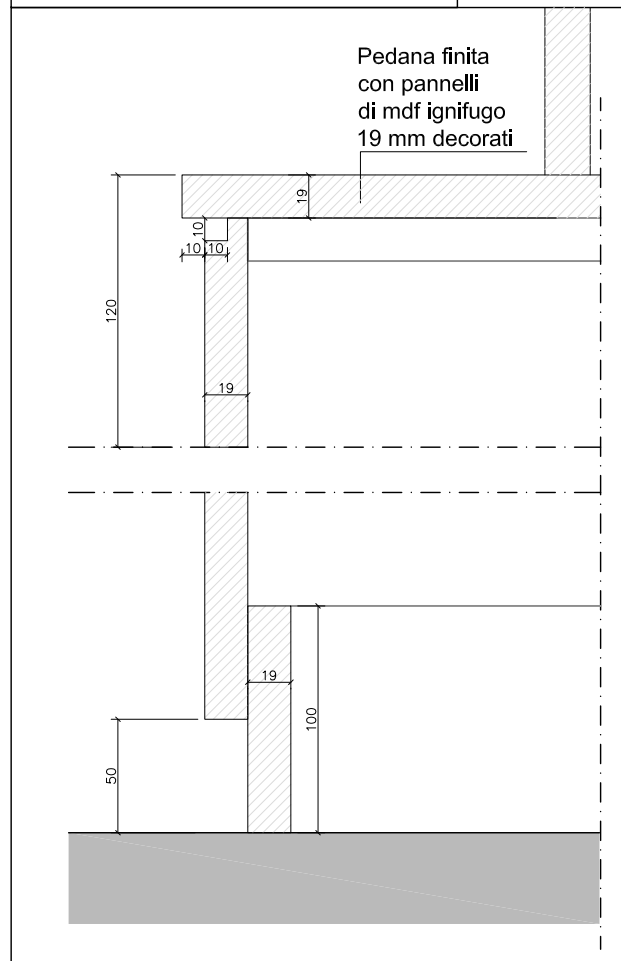

PIANTA

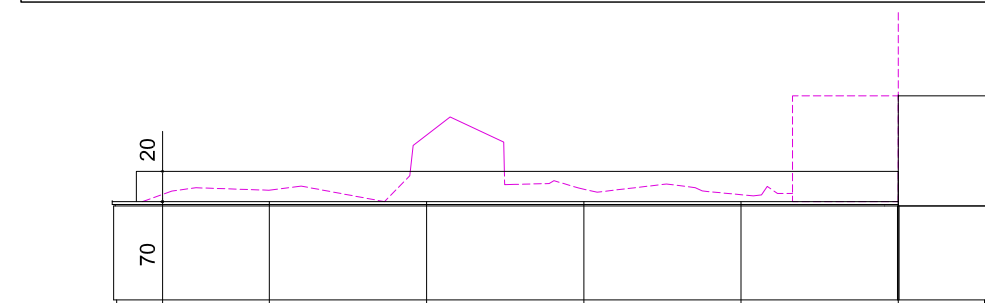

PROSPETTO

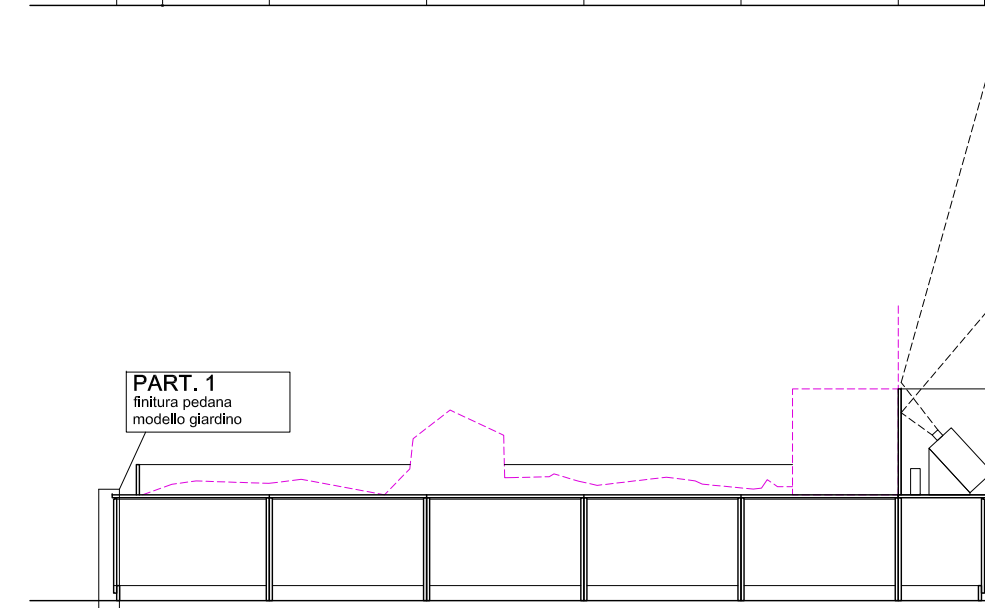

SEZIONE

S0.AV02
S0.AV03
Appendimento arazzo

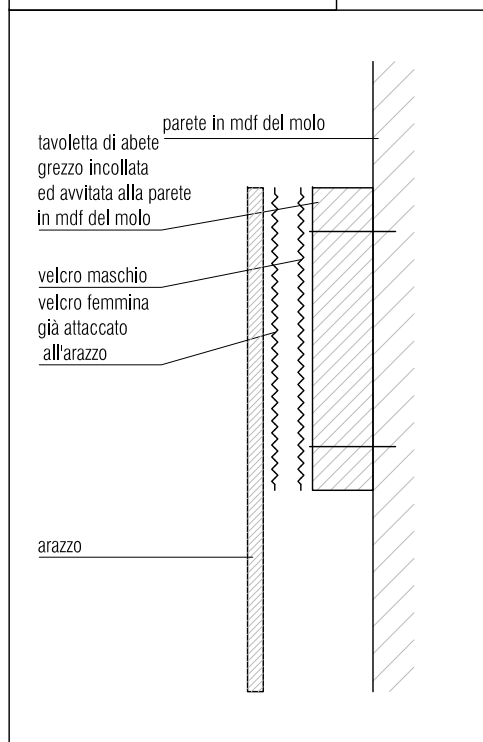

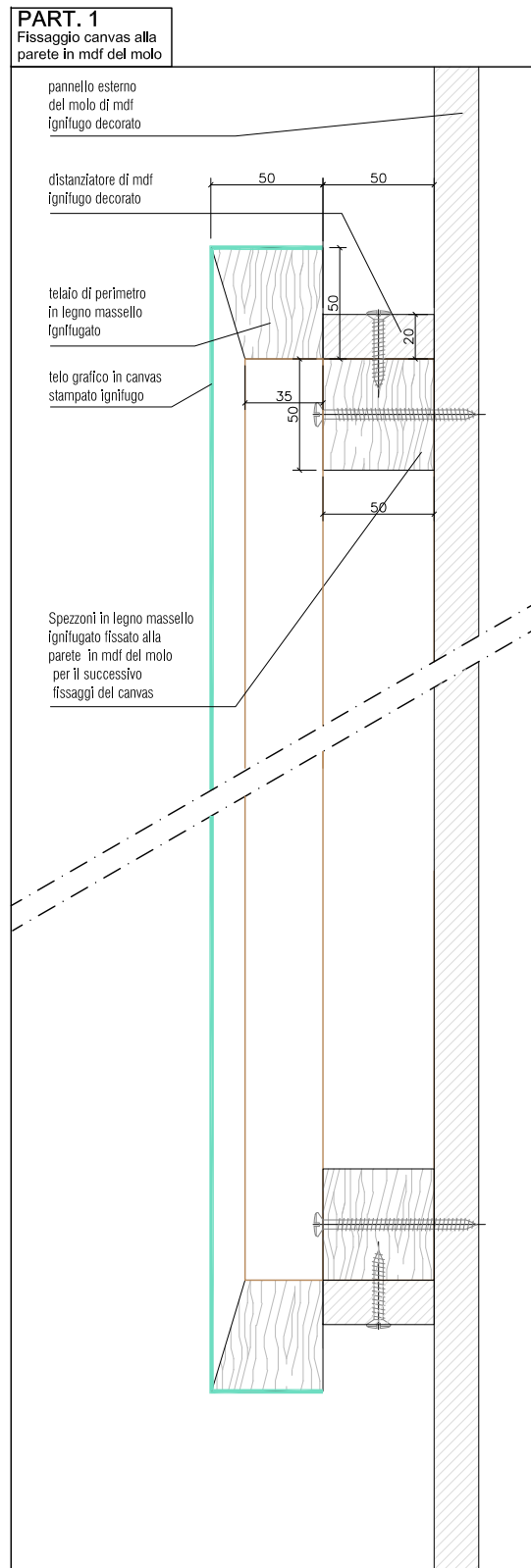

S0.C01/C02
Telaio ligneo sparapuntato con telo grafico realizzato in masselli di legno ignifugato

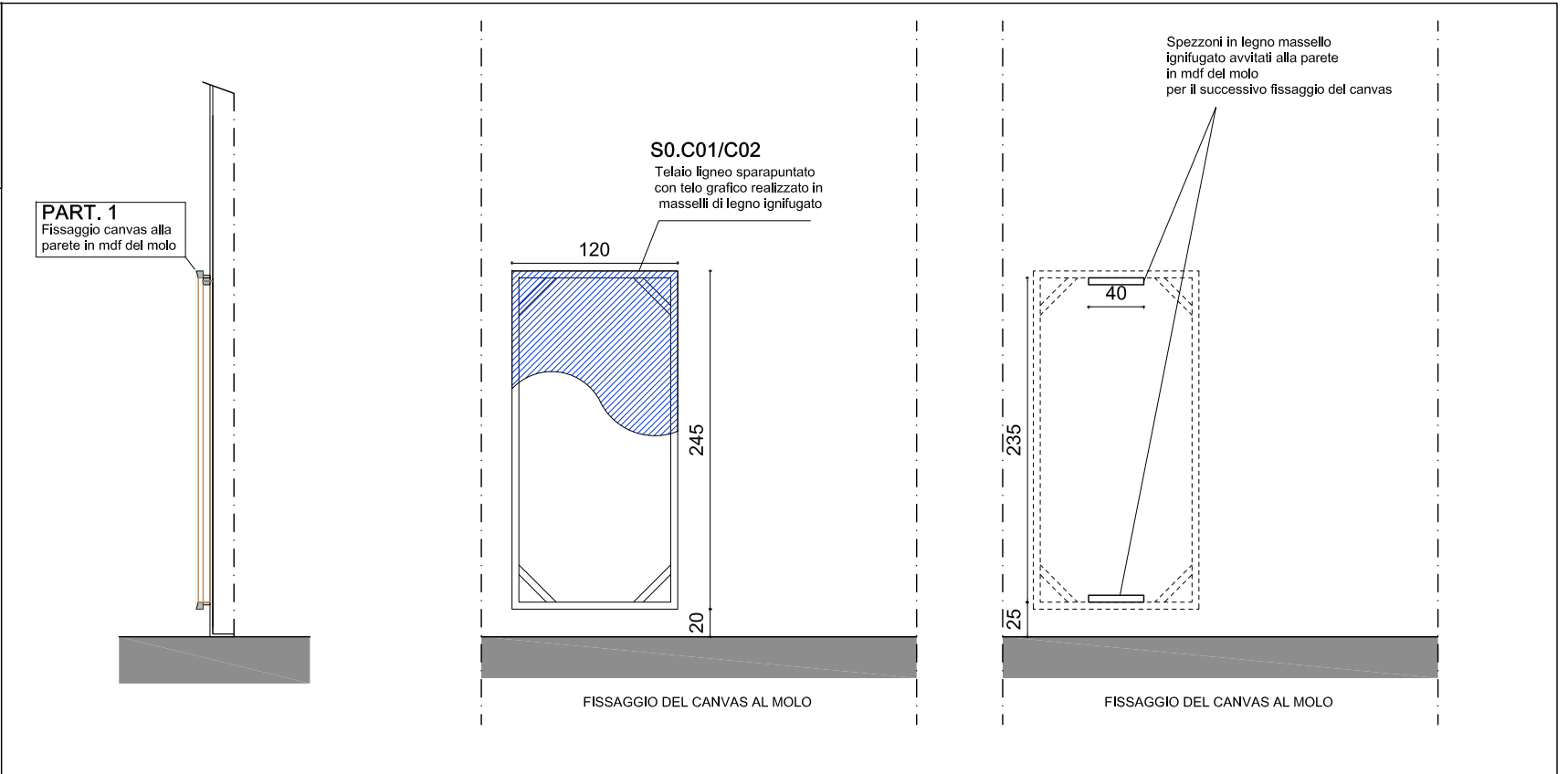

S0.CO3
Telaio ligneo sparapuntato con telo grafico realizzato in masselli di legno ignifugato

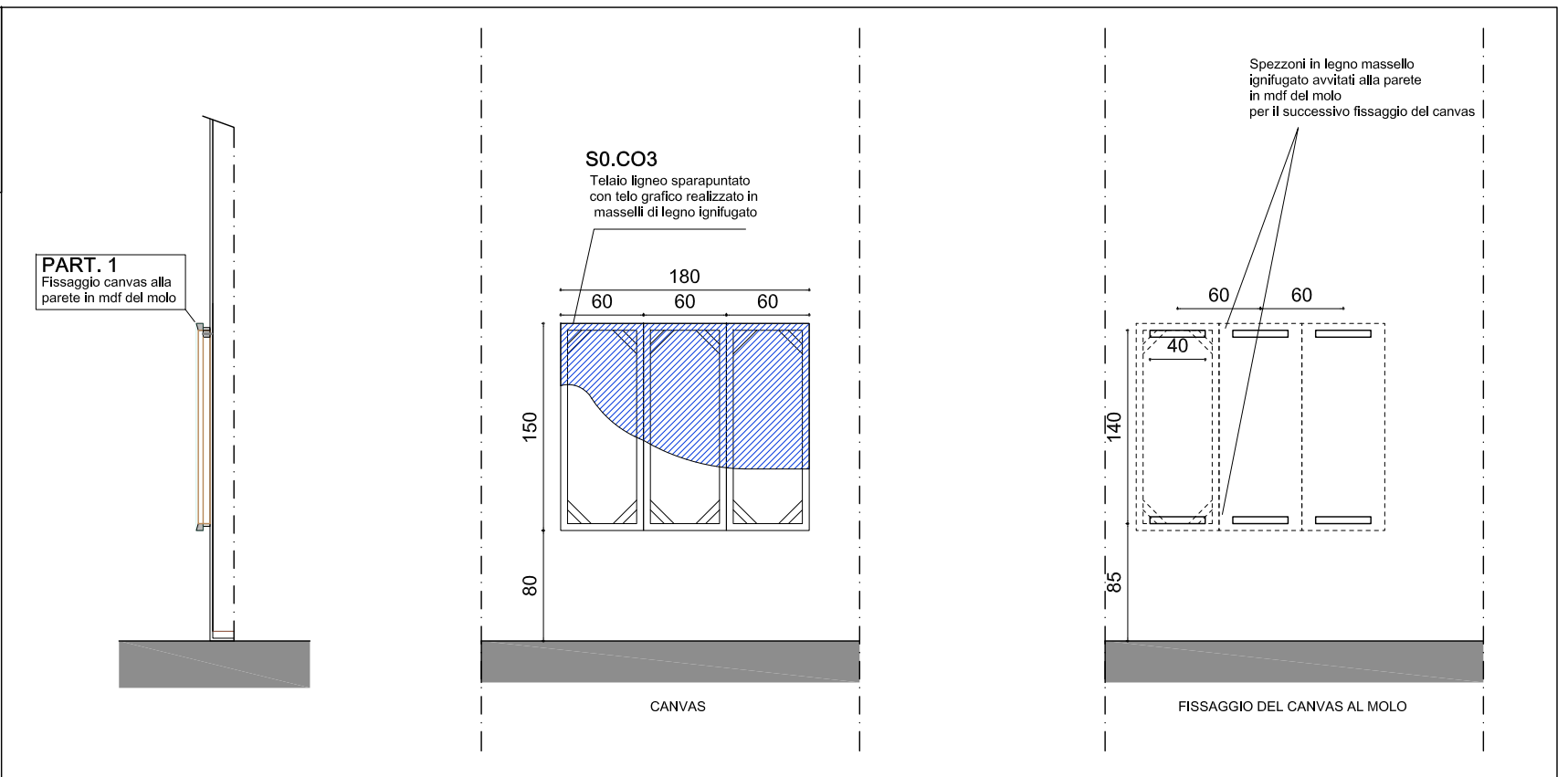

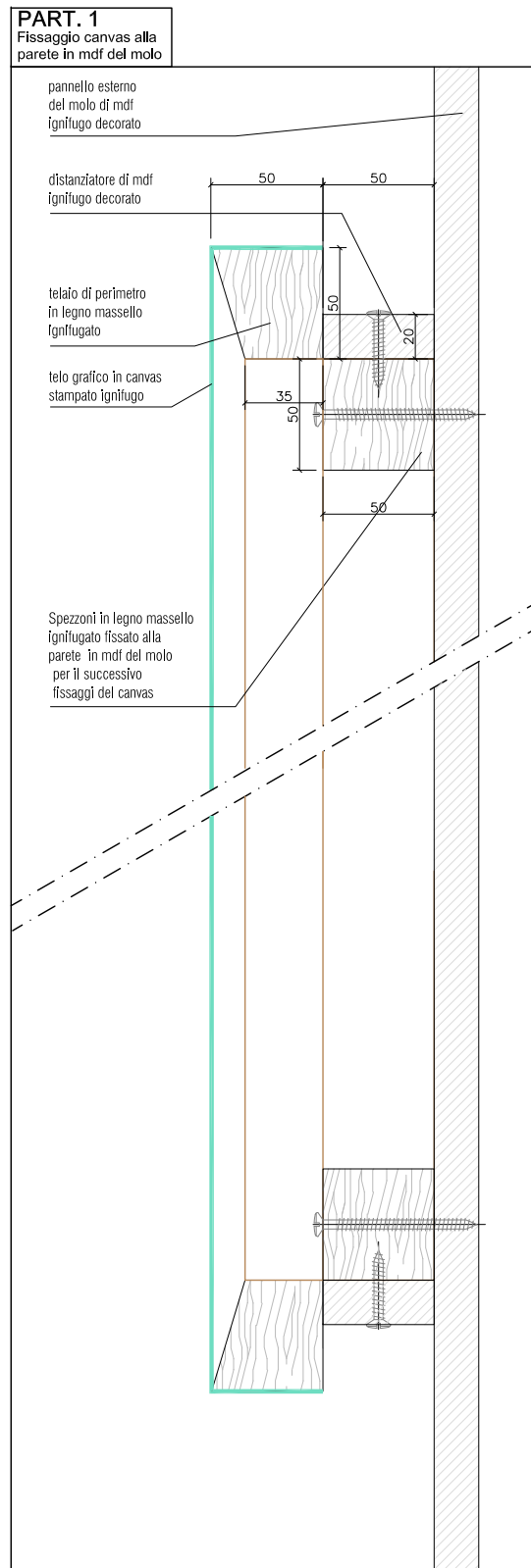

S0.CO4
Telaio ligneo sparapuntato con telo grafico realizzato in masselli di legno ignifugato

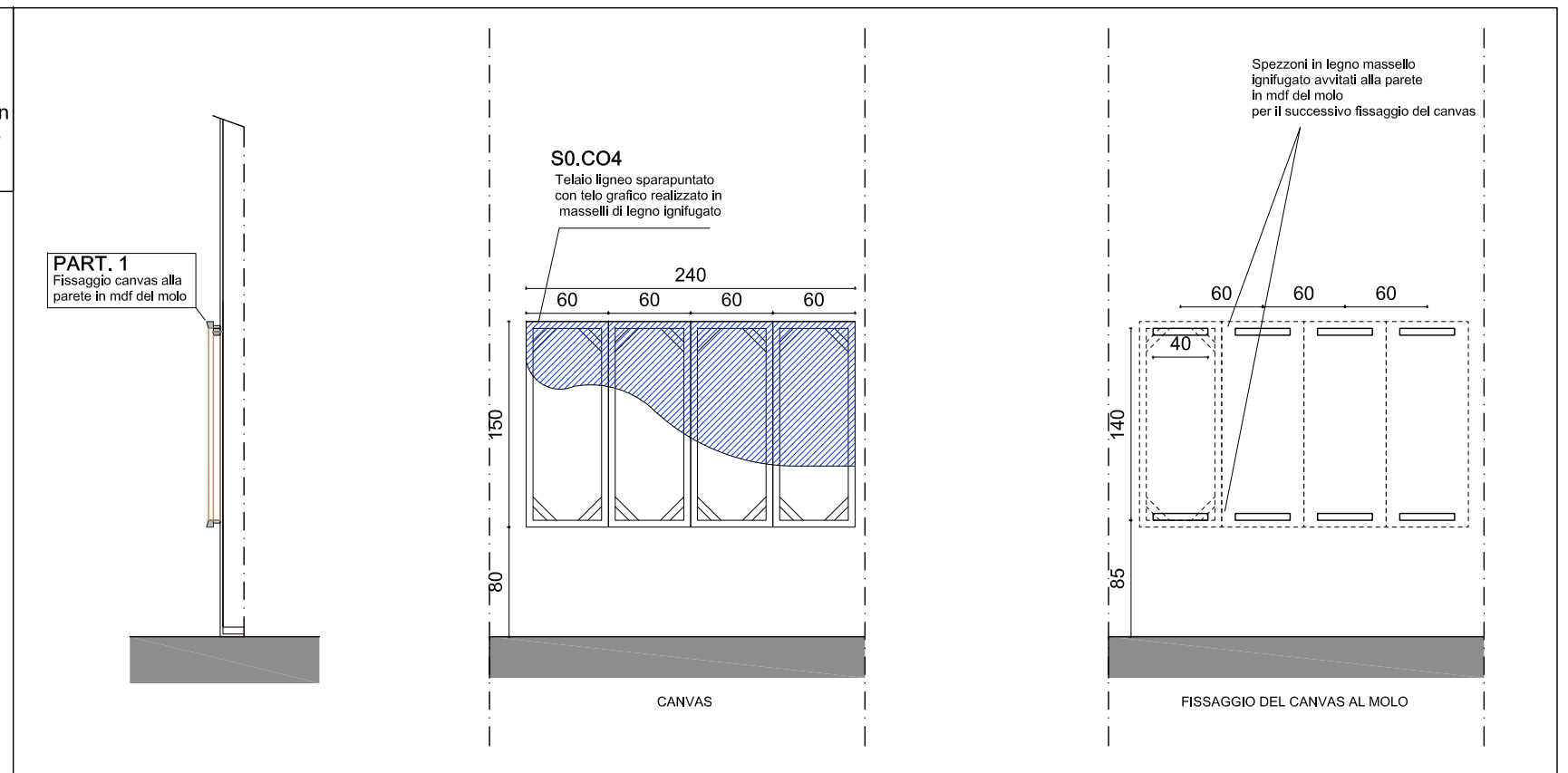

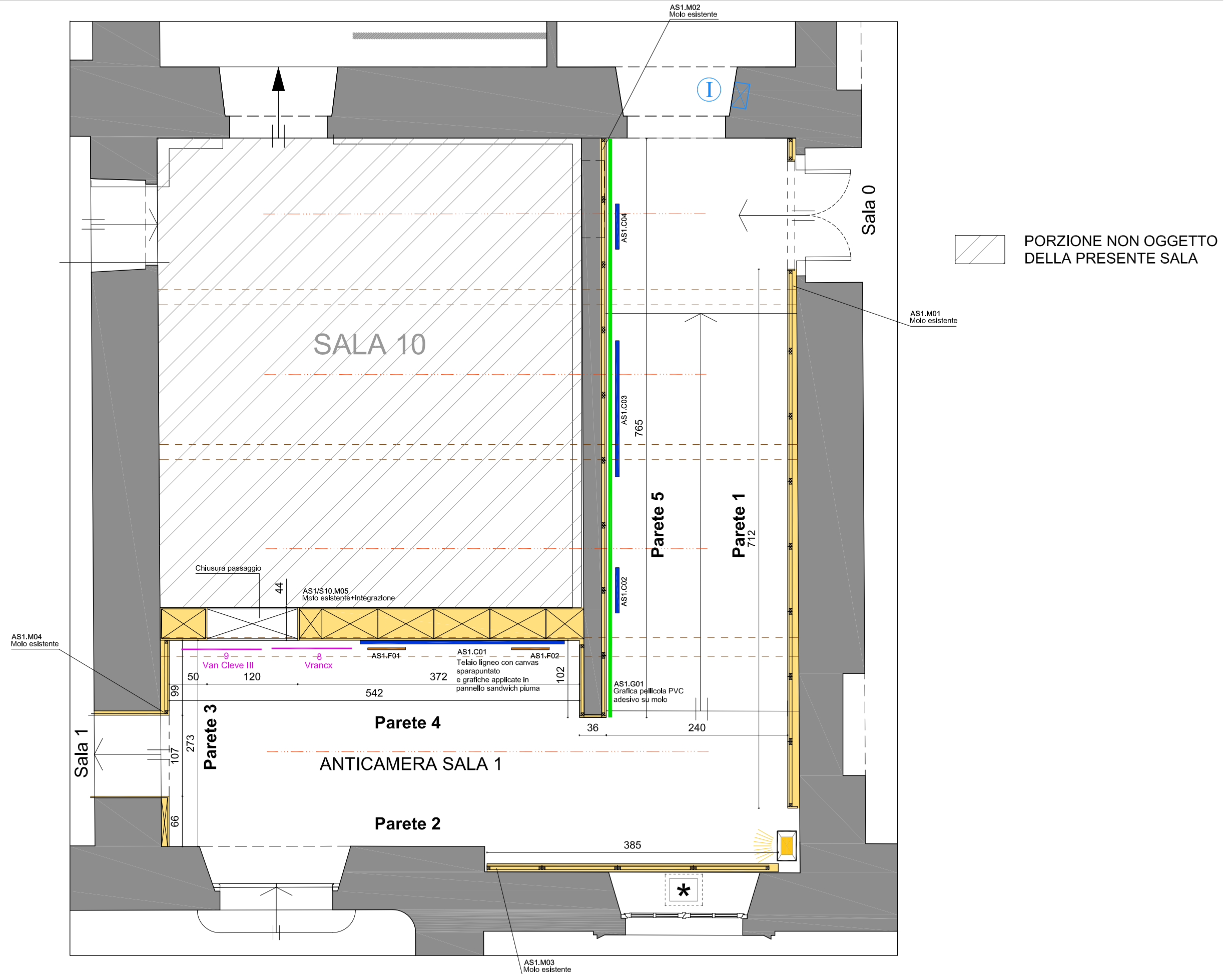

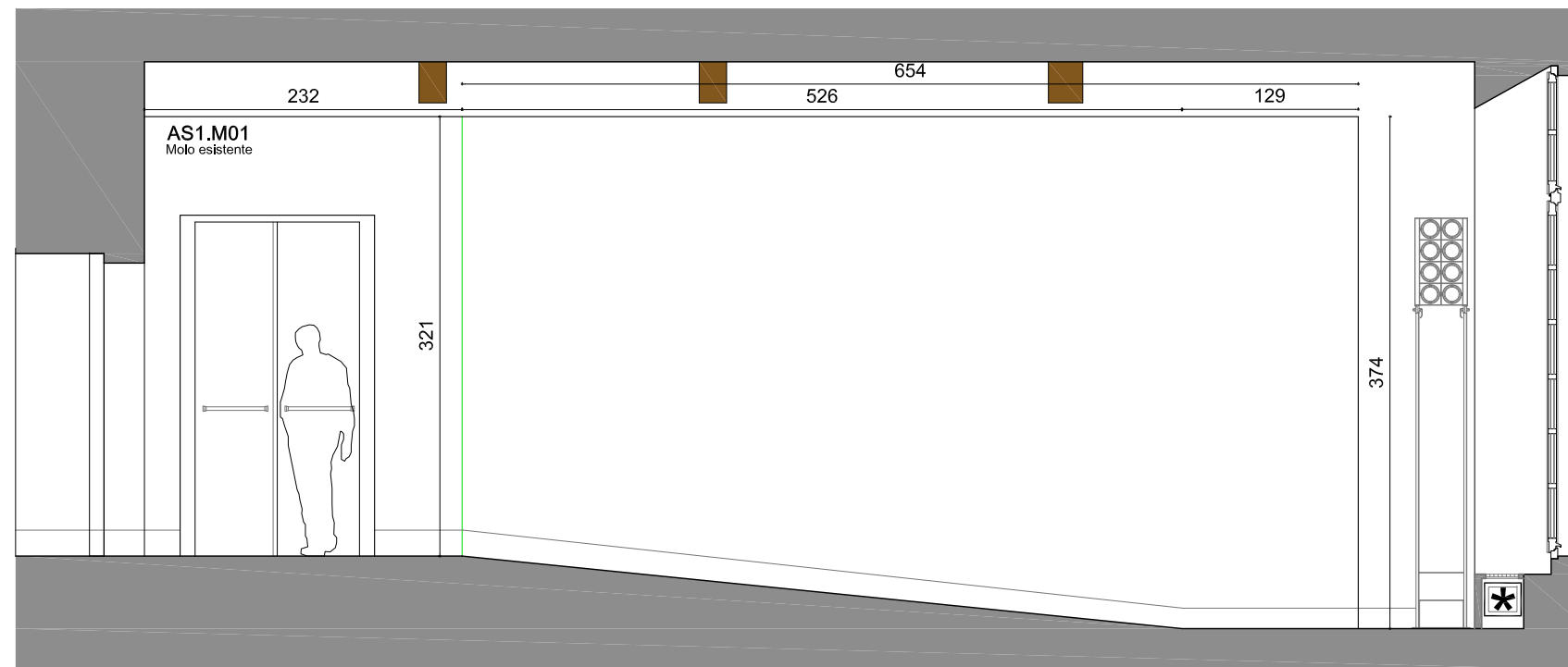

Parete 1

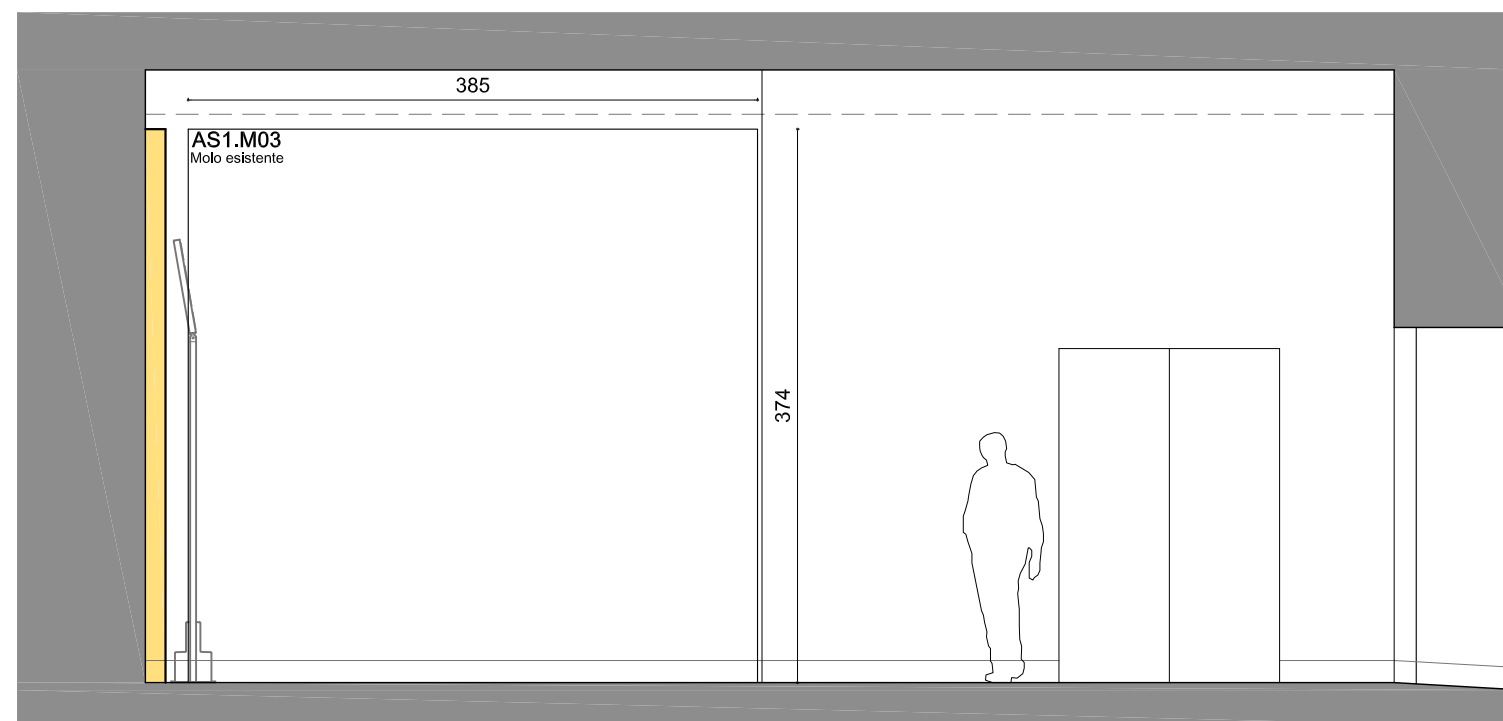

Parete 2

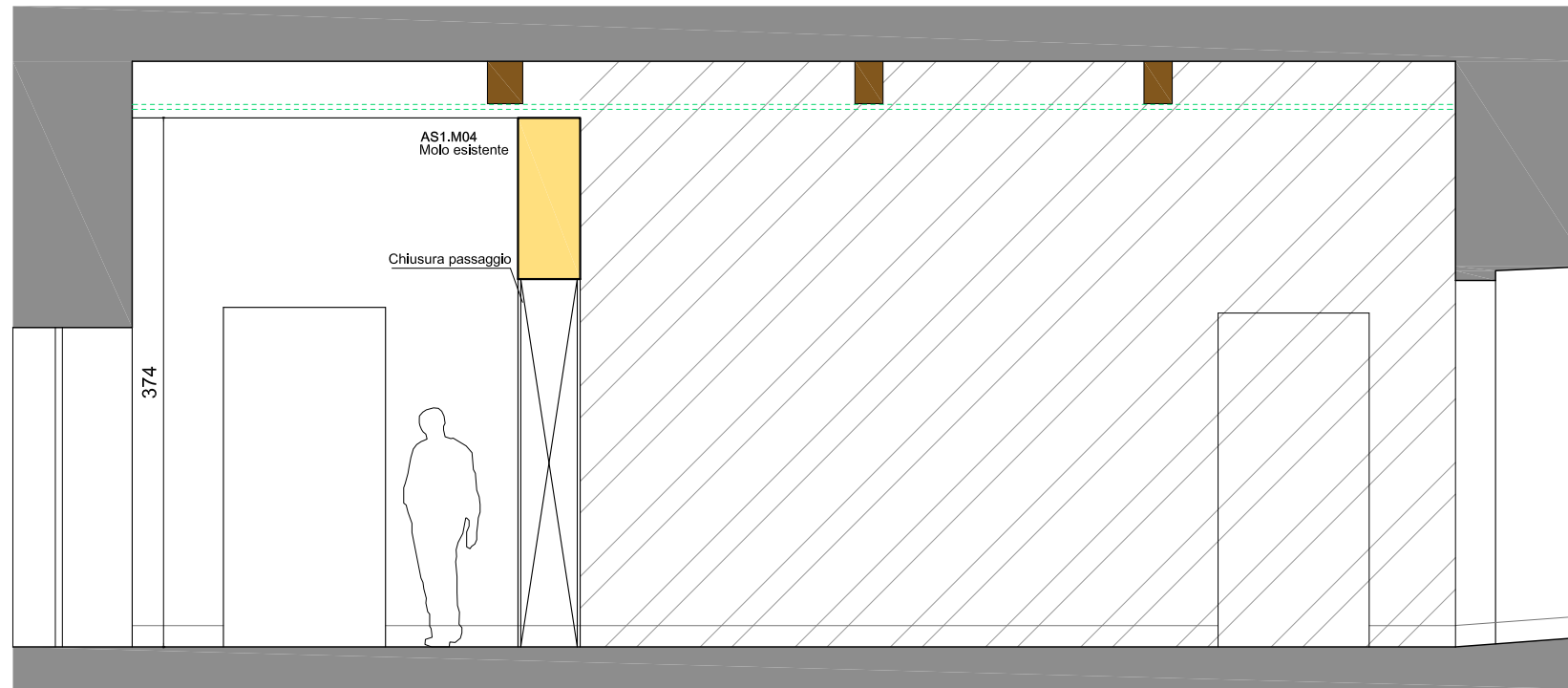

Parete 3

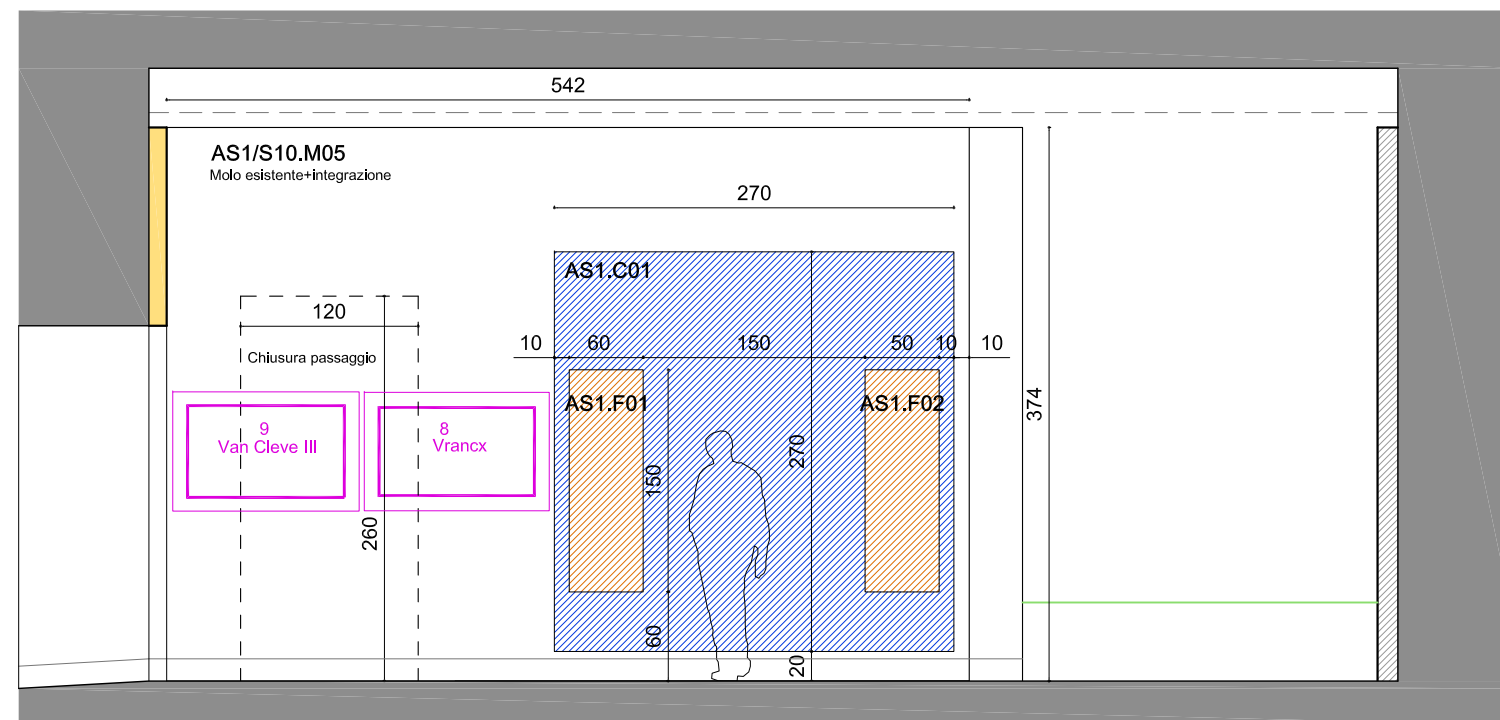

Parete 4

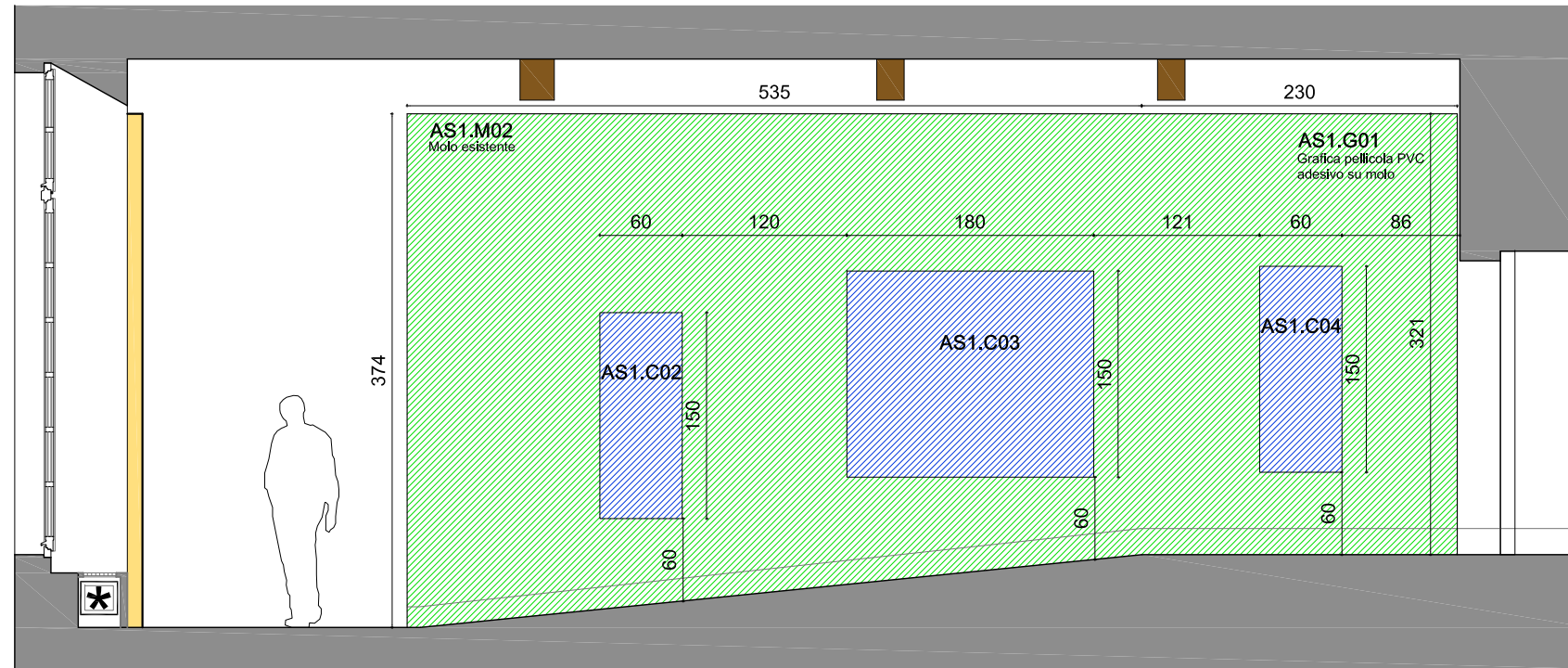

Parete 5

PART. 1
Fissaggio canvas alla parete in mdf del molo

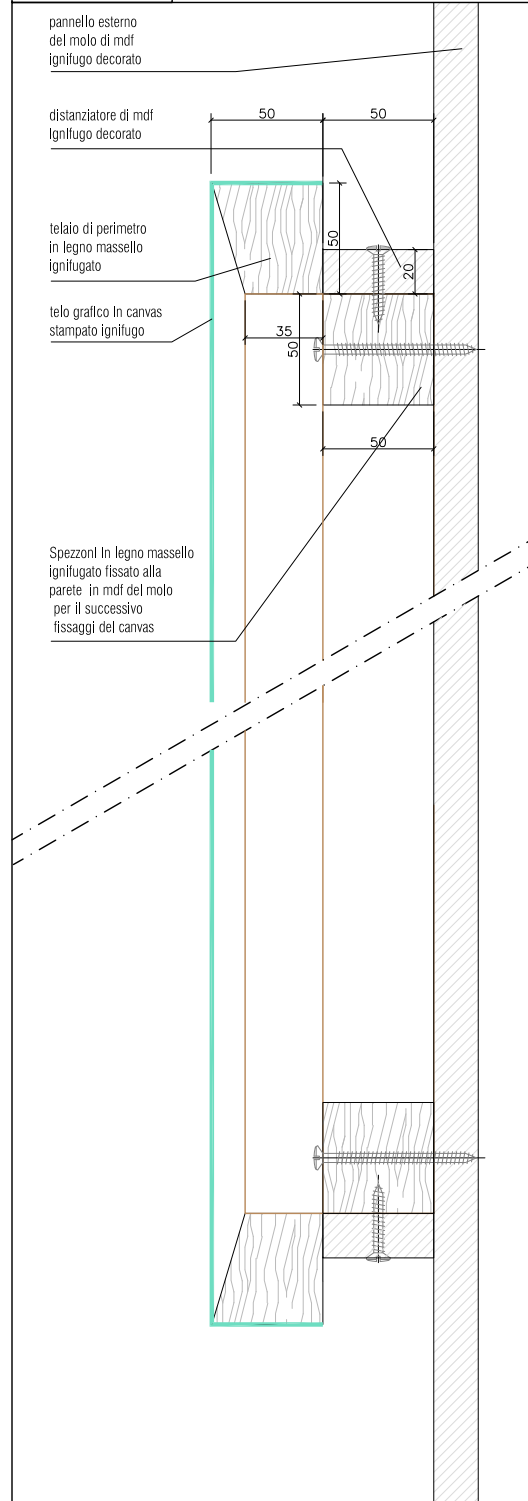

AS1.C02/C04
Telaio ligneo sparapuntato con telo grafico realizzato in masselli di legno ignifugato

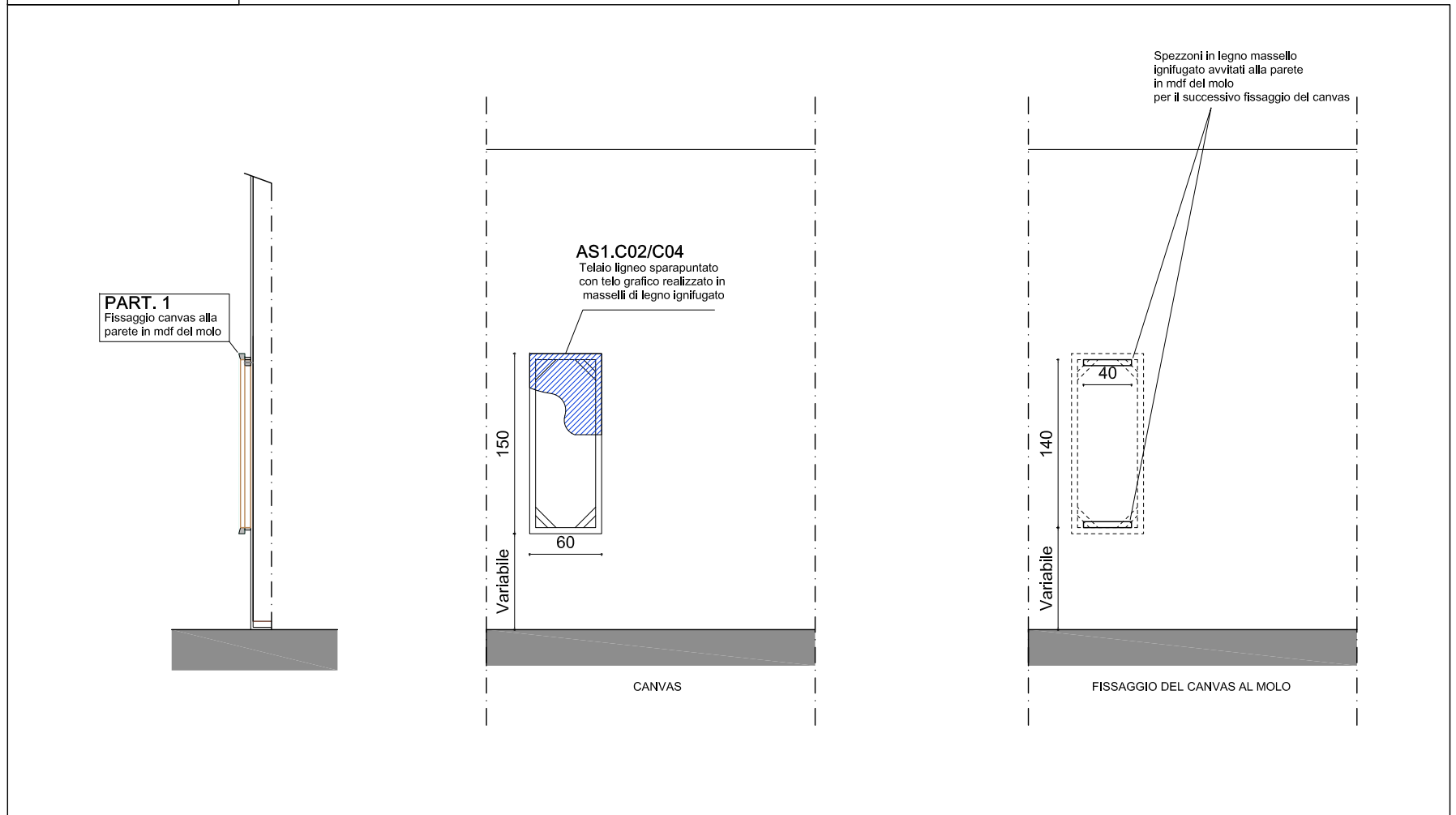

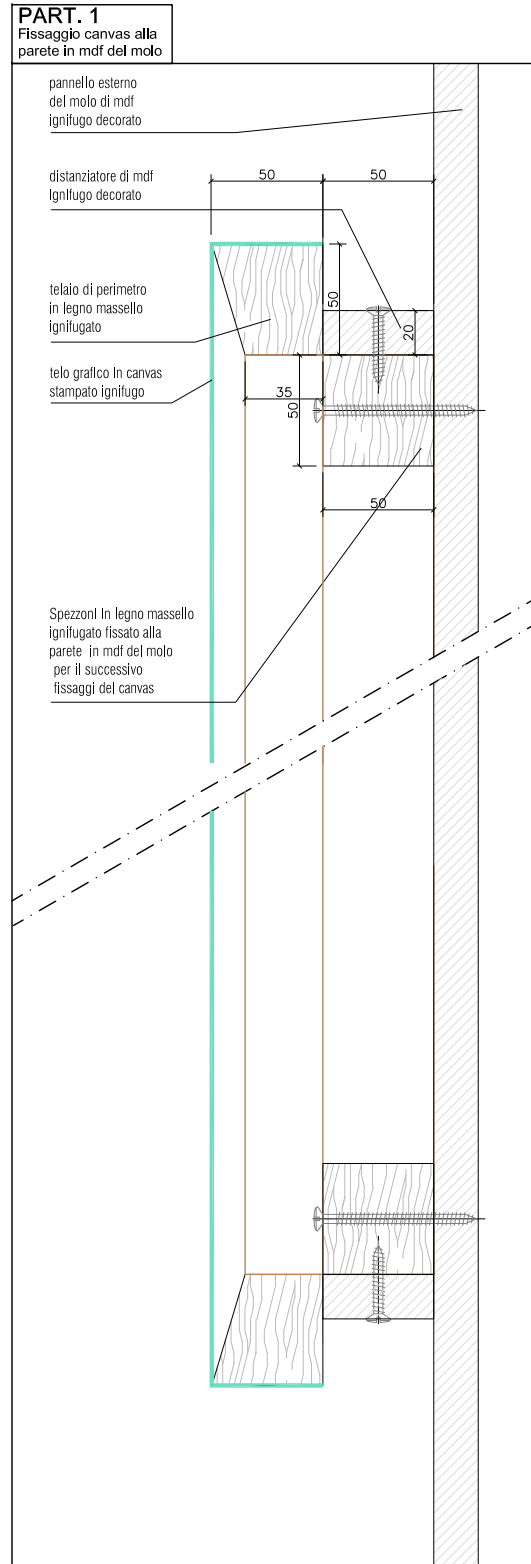

AS1.C03
Telaio ligneo sparapuntato con telo grafico realizzato in masselli di legno ignifugato

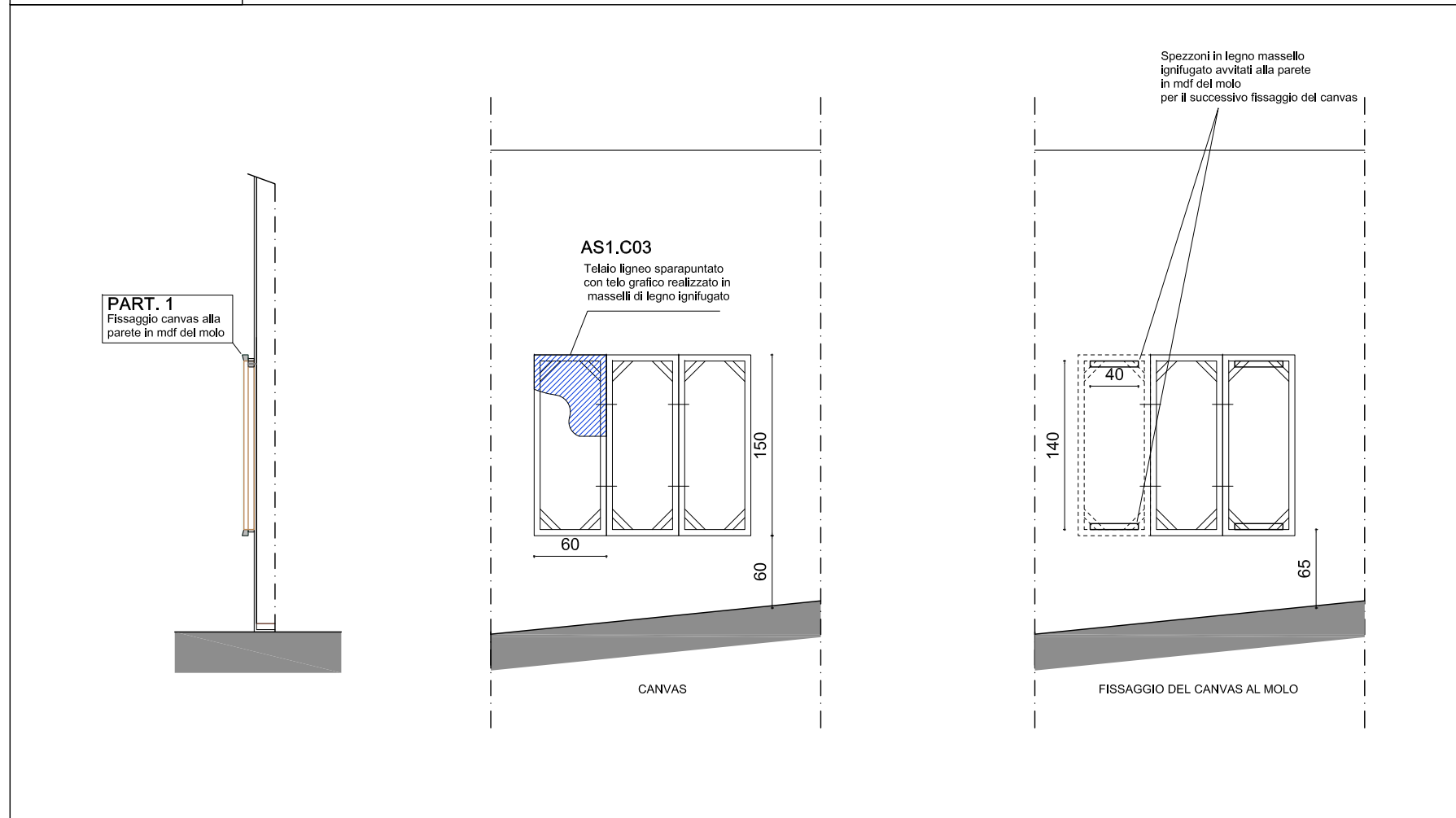

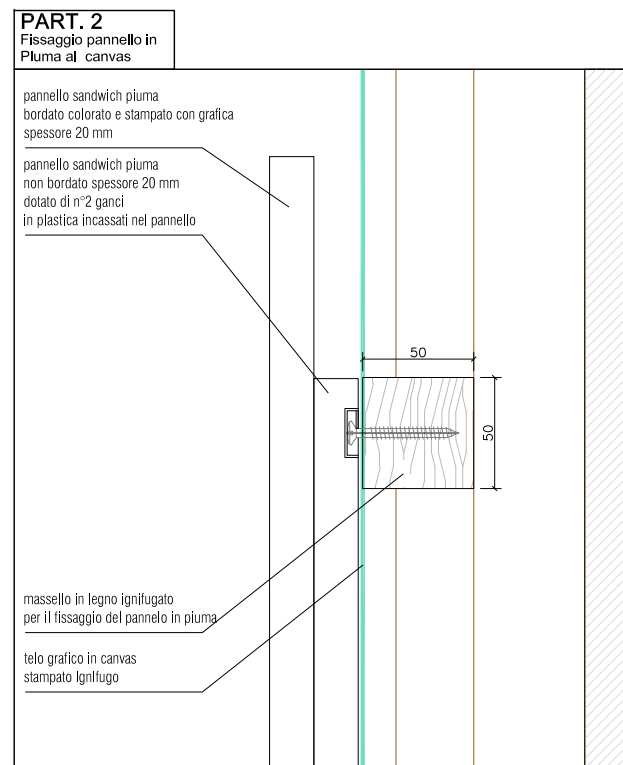
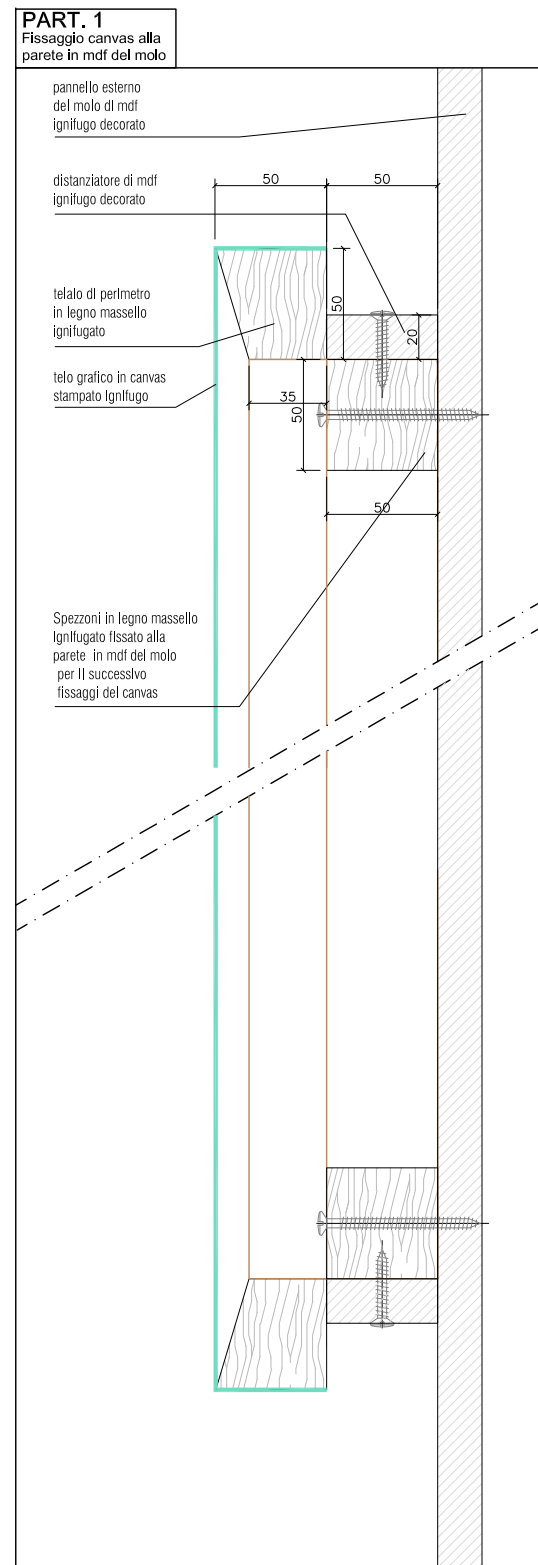

AS1.C01
Telaio ligneo sparapuntato con telo grafico realizzato in masselli di legno ignifugato

AS1.F01/F02
Doppio pannello in piuma spessore 20 mm

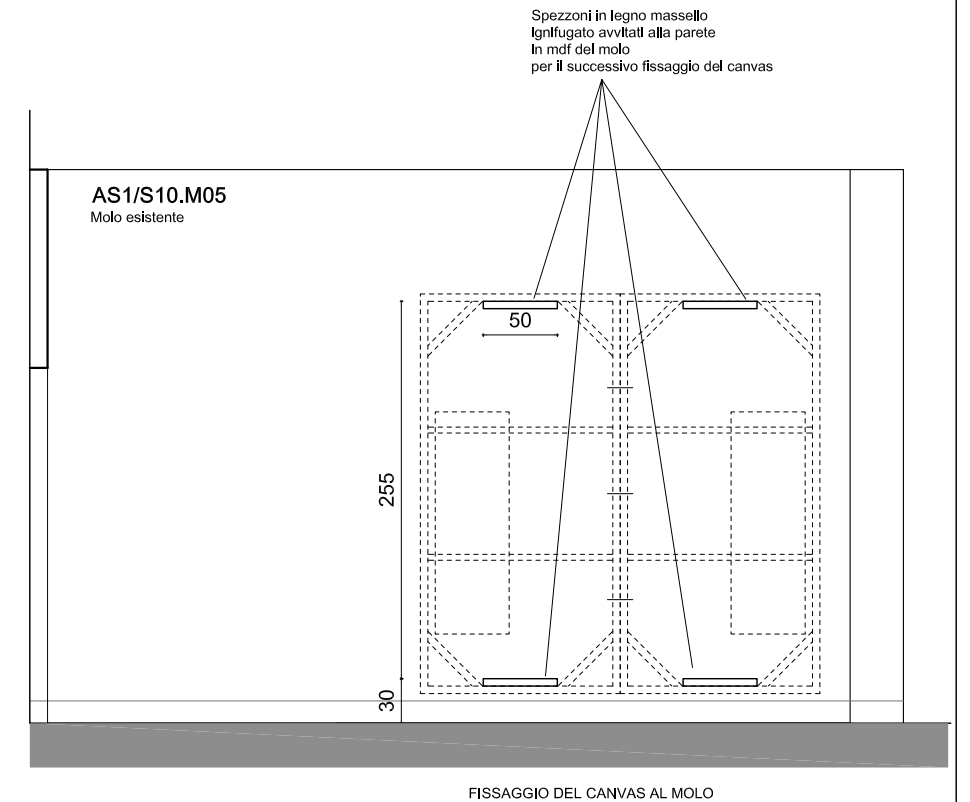
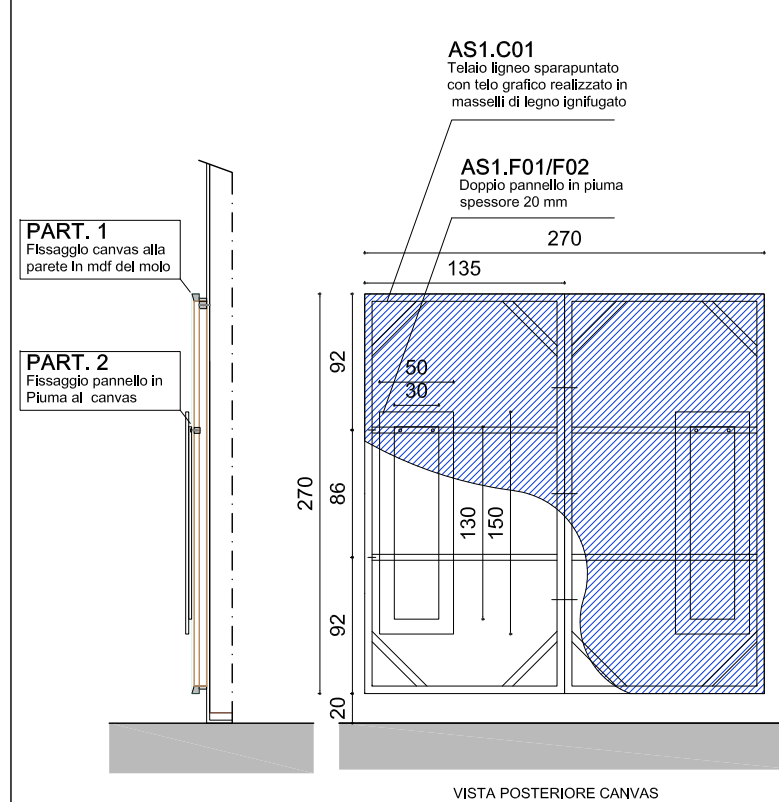

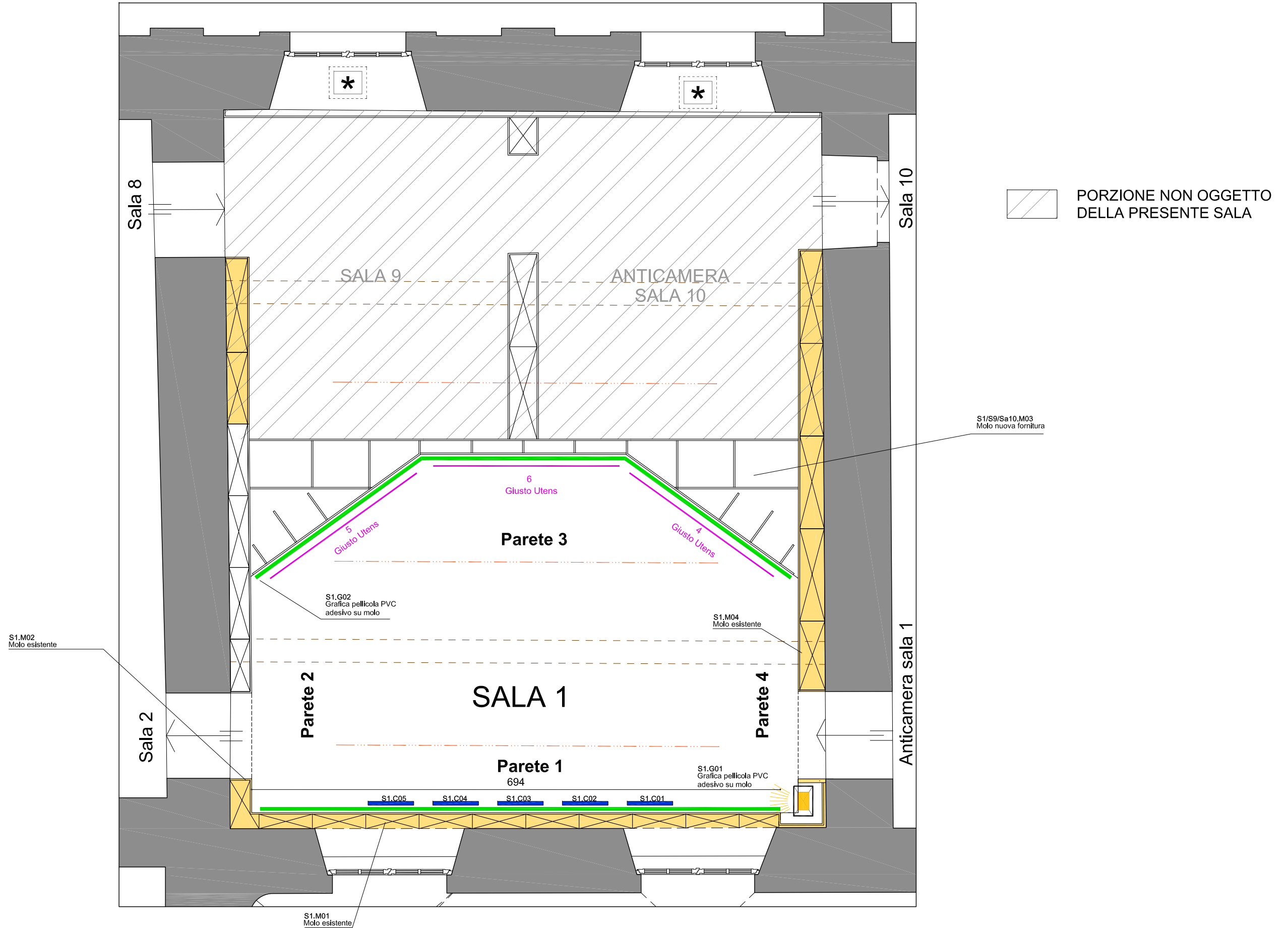

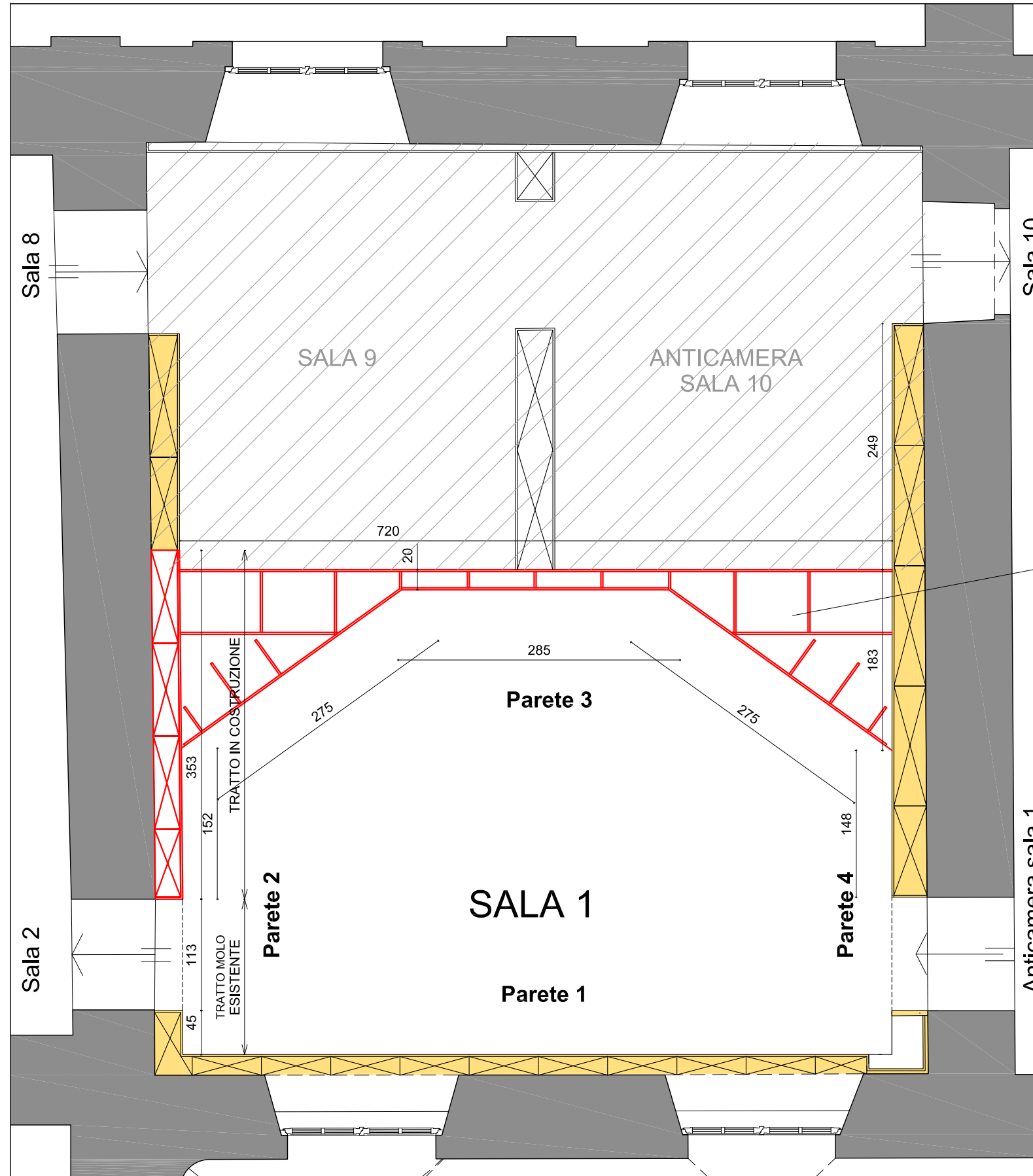



 PORZIONE NON OGGETTO DELLA PRESENTE SALA

 COSTRUZIONE

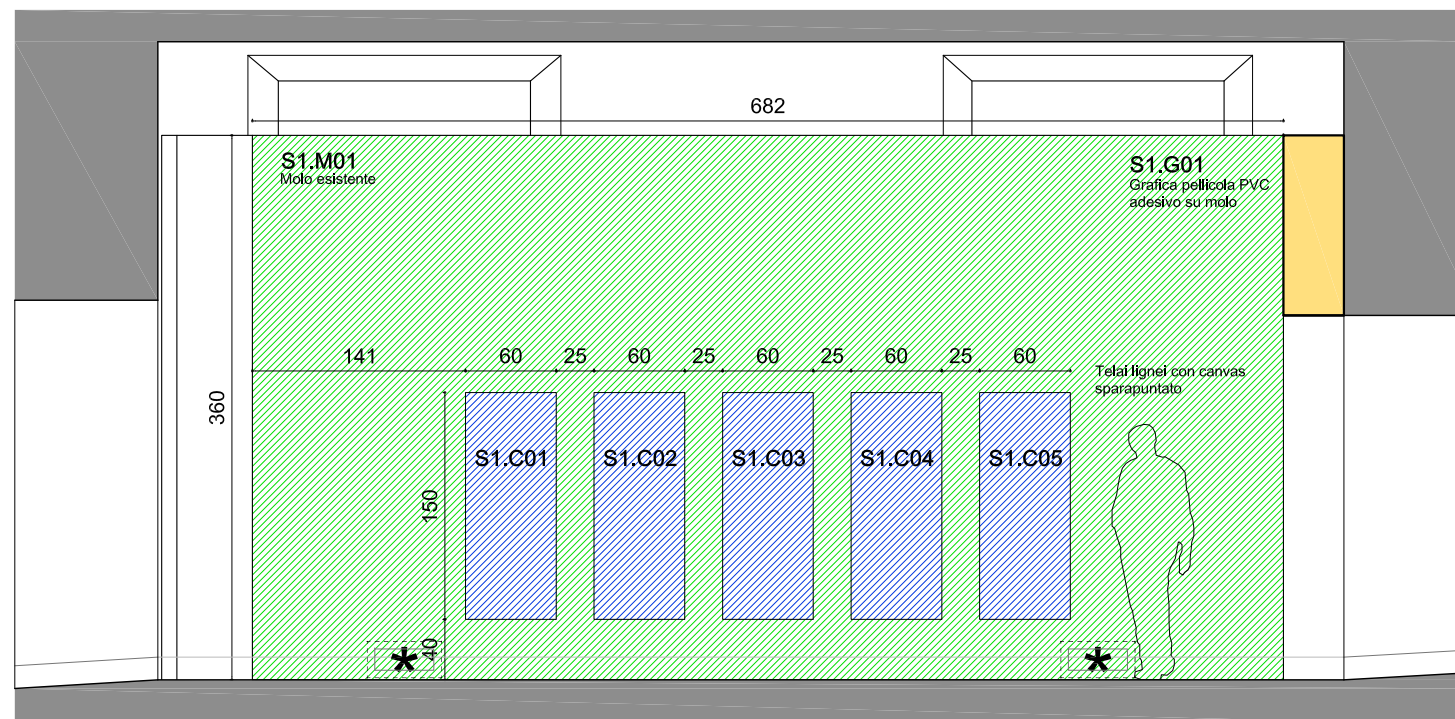
S1/S9/Sa10.M03
Molo nuova fornitura



-  COSTRUZIONE
-  PORZIONE NON OGGETTO DELLA PRESENTE SALA

Parete 1

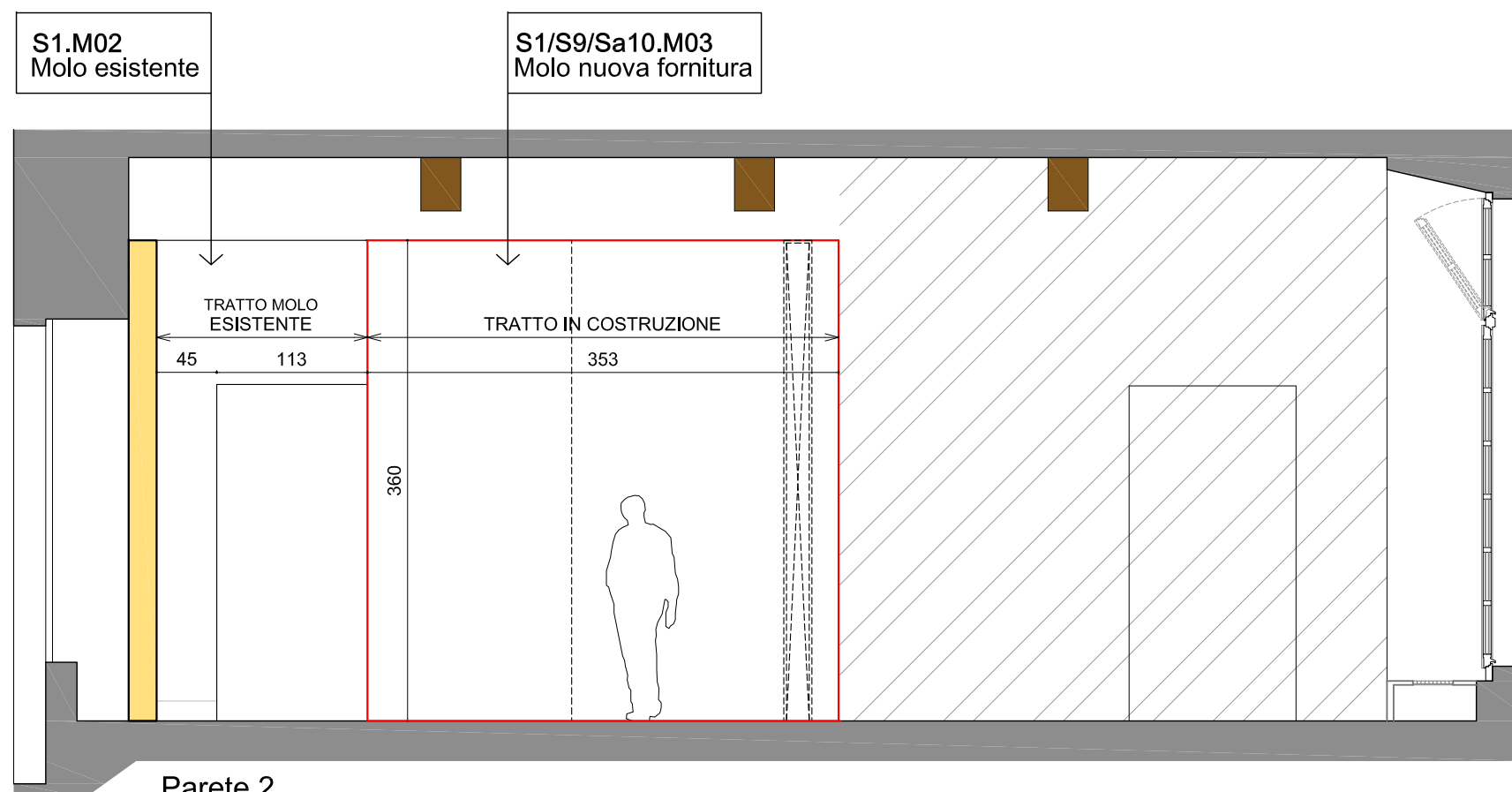

Parete 2

S1/S9/Sa10.M03
Molo nuova fornitura

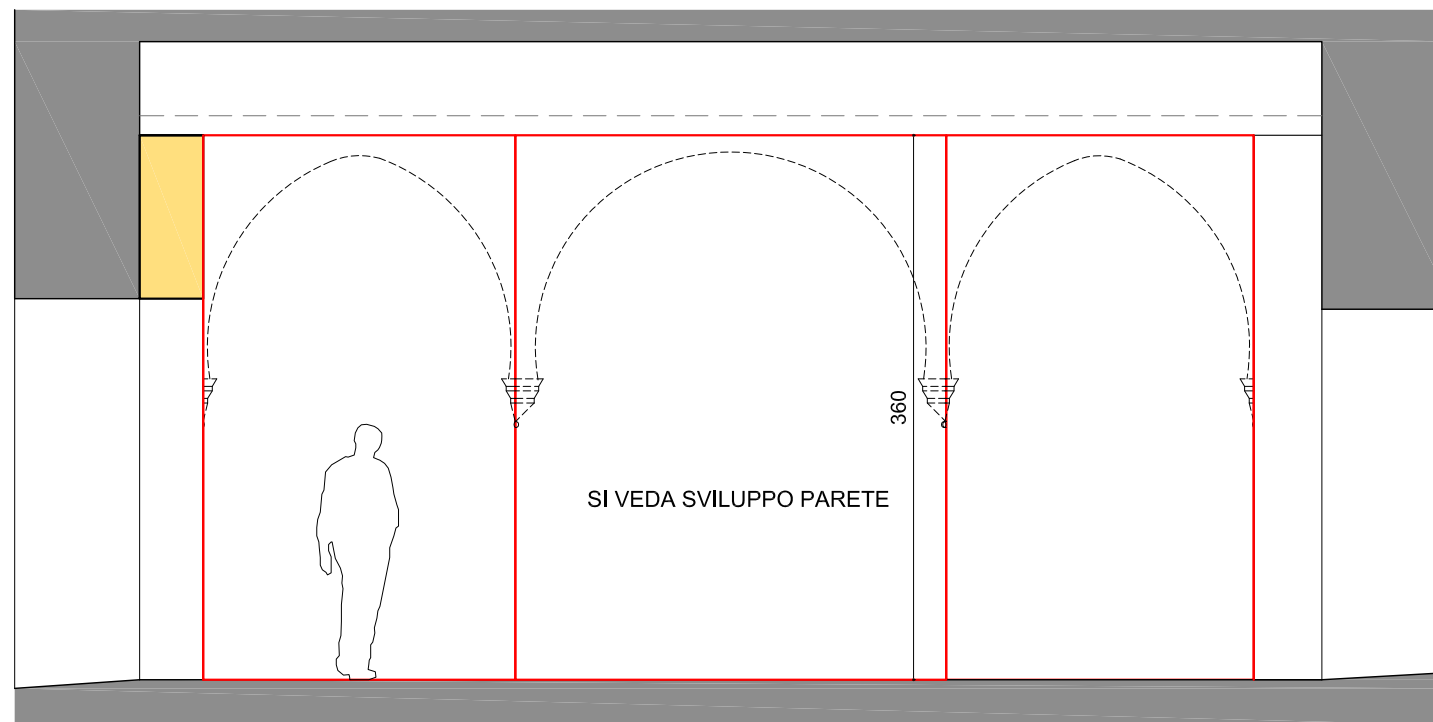

Parete 3

 COSTRUZIONE

 PORZIONE NON OGGETTO DELLA PRESENTE SALA

S1/S9/Sa10.M03
Molo nuova fornitura

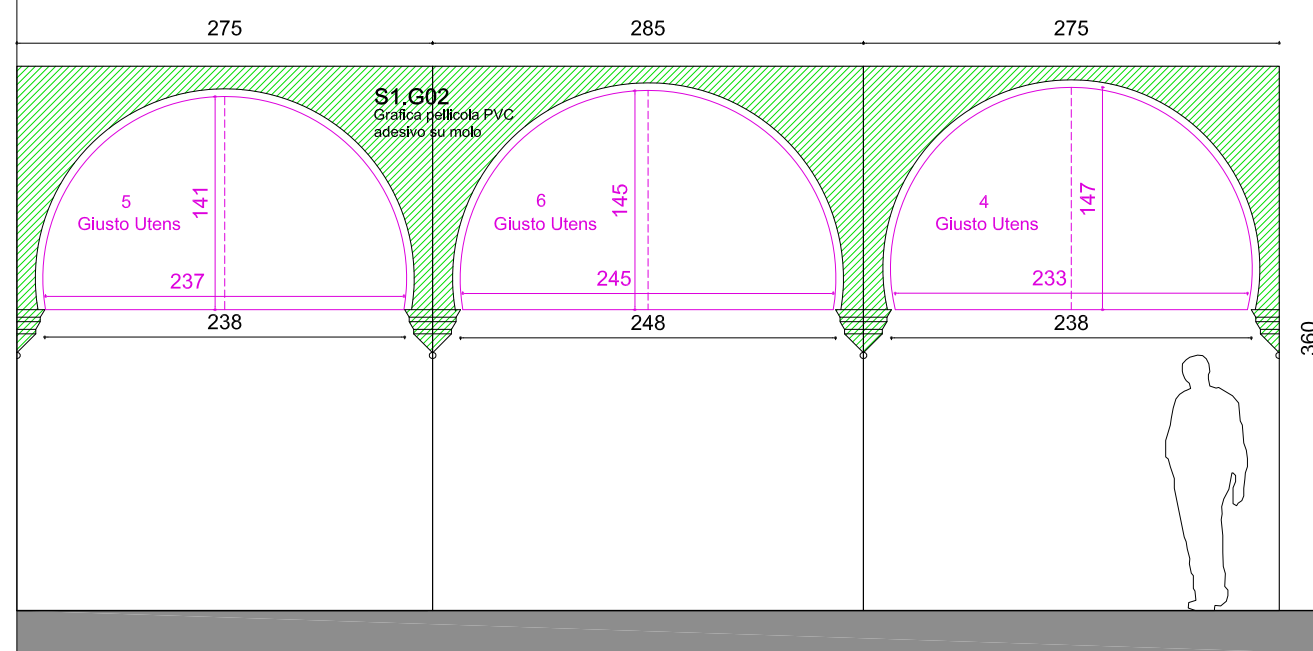

Sviluppo parete 3

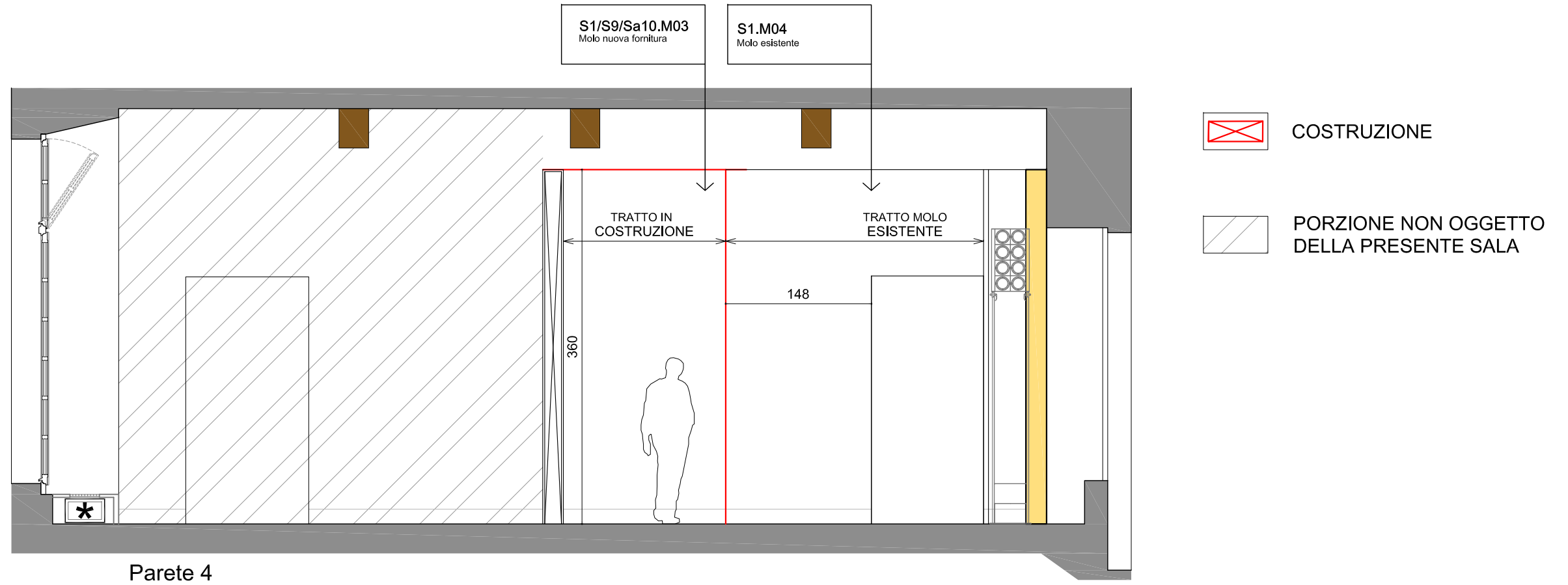

PART. 1
Fissaggio canvas alla parete in mdf del mofo

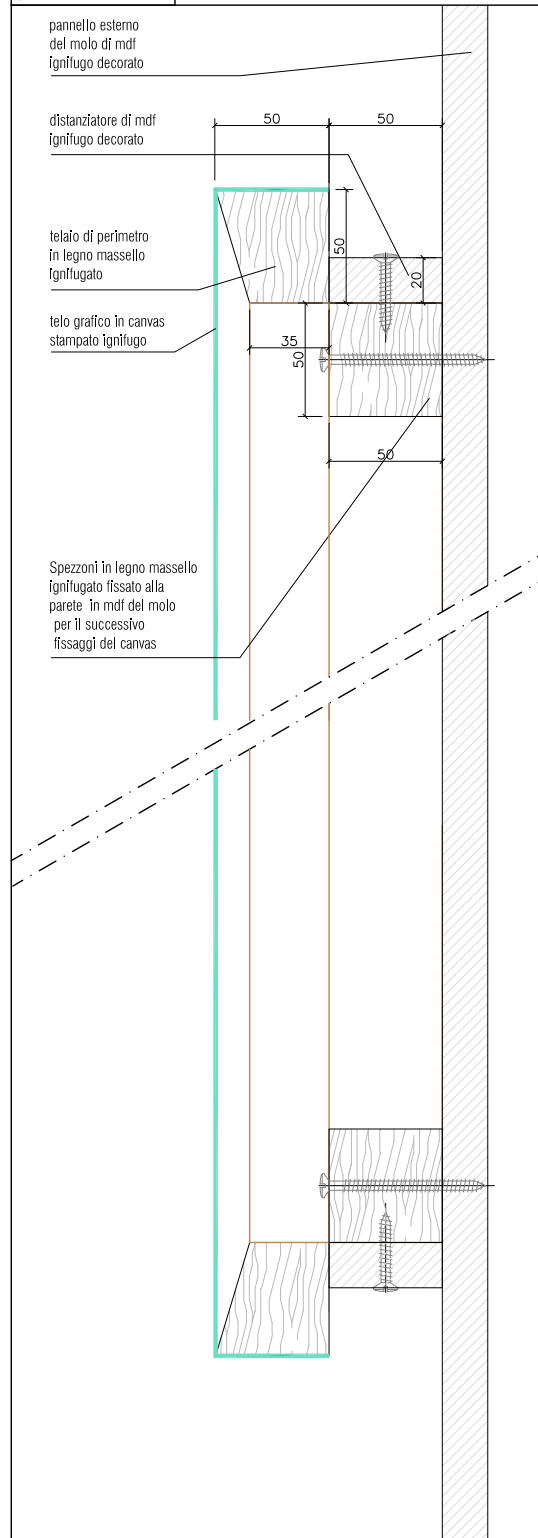

S1.C01/C02/C03/C04/C05
Telaio ligneo sparapuntato con telo grafico realizzato in masselli di legno ignifugato

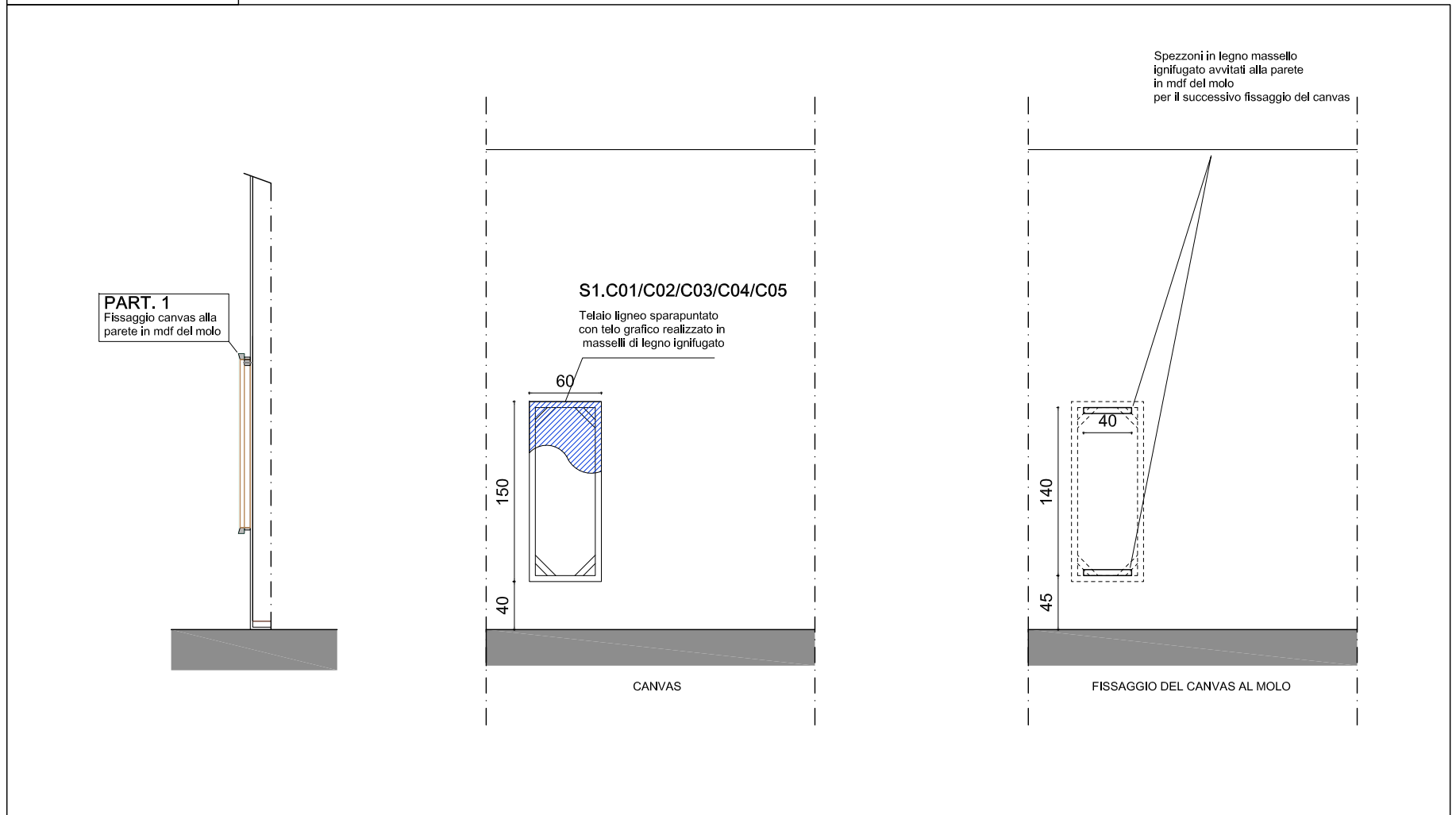

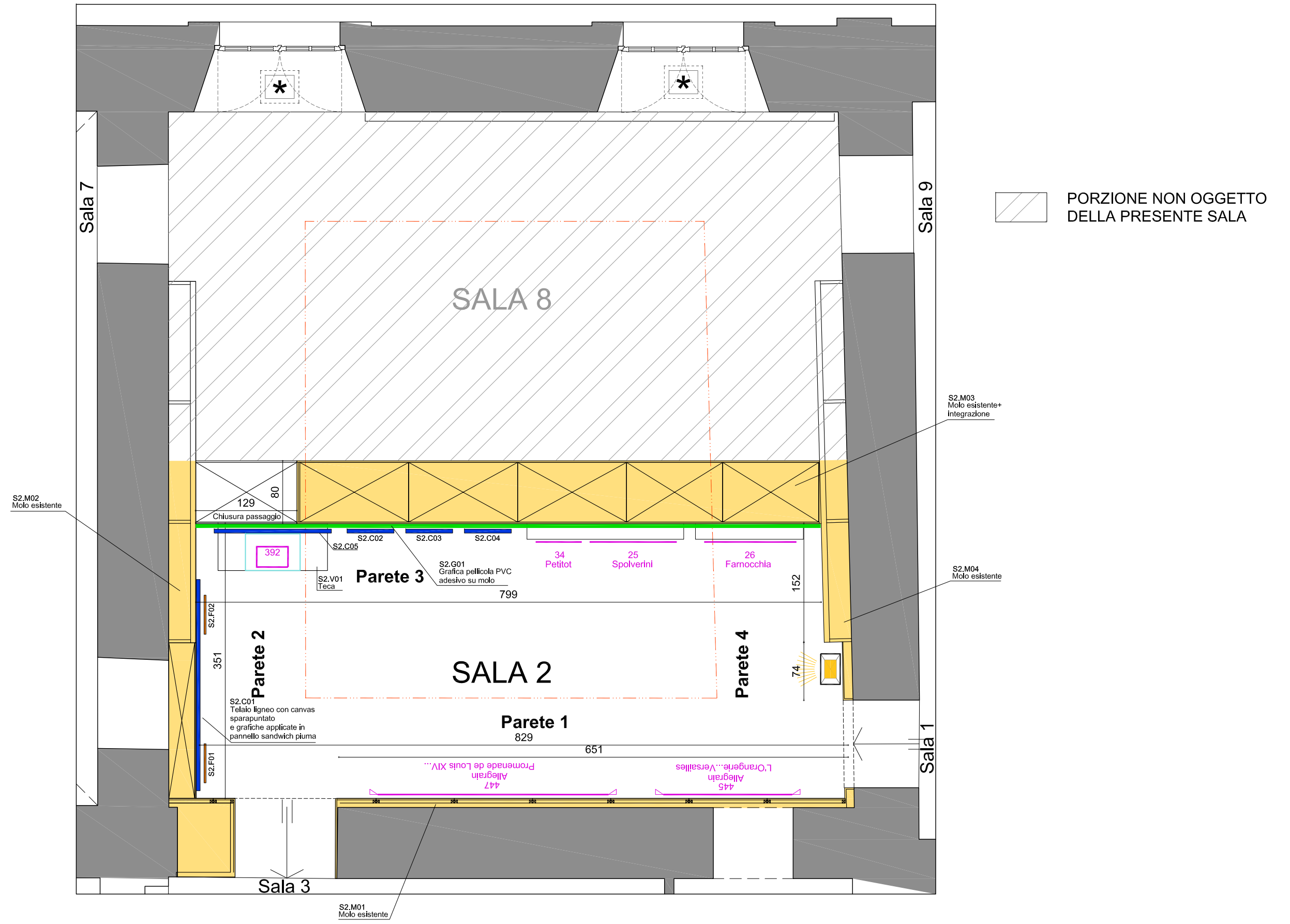

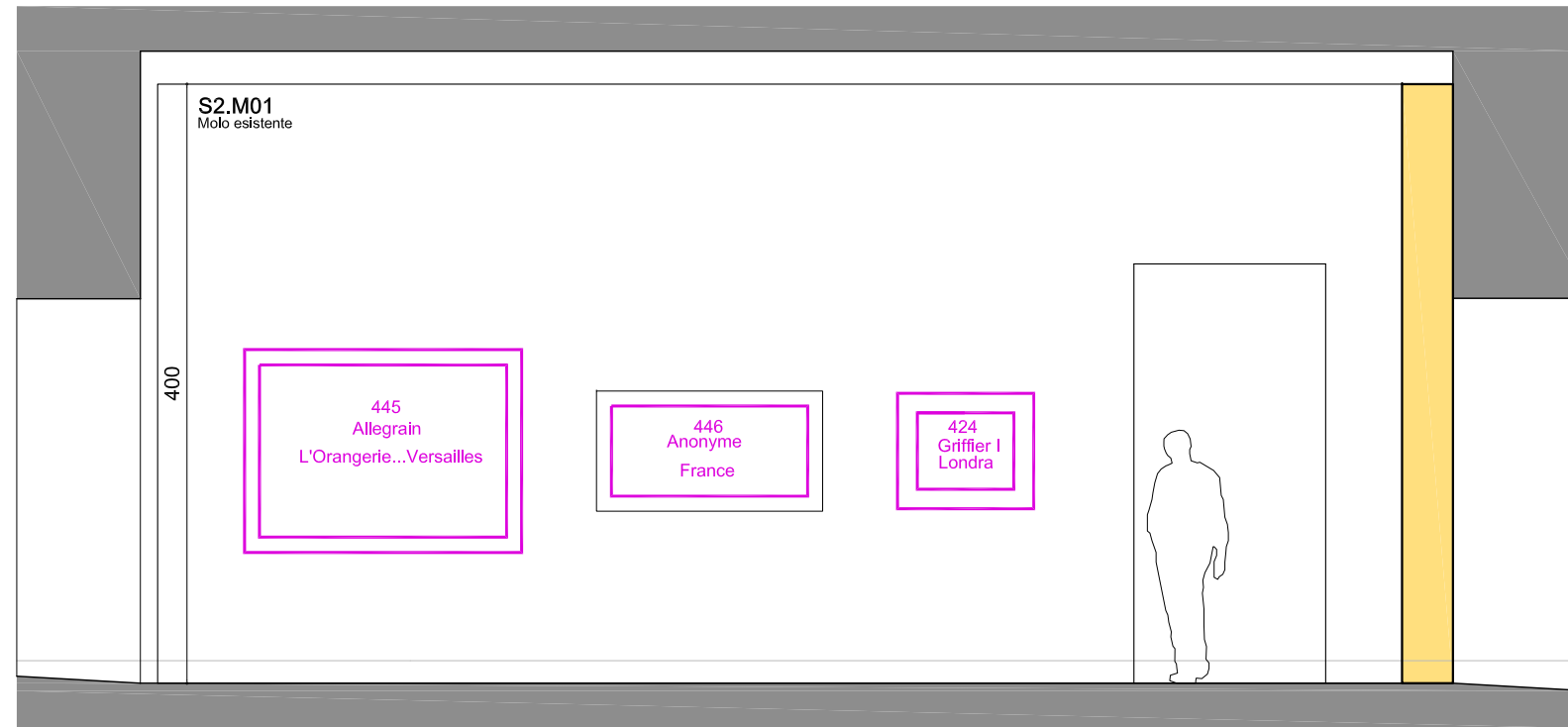

 PORZIONE NON OGGETTO DELLA PRESENTE SALA

Parete 1

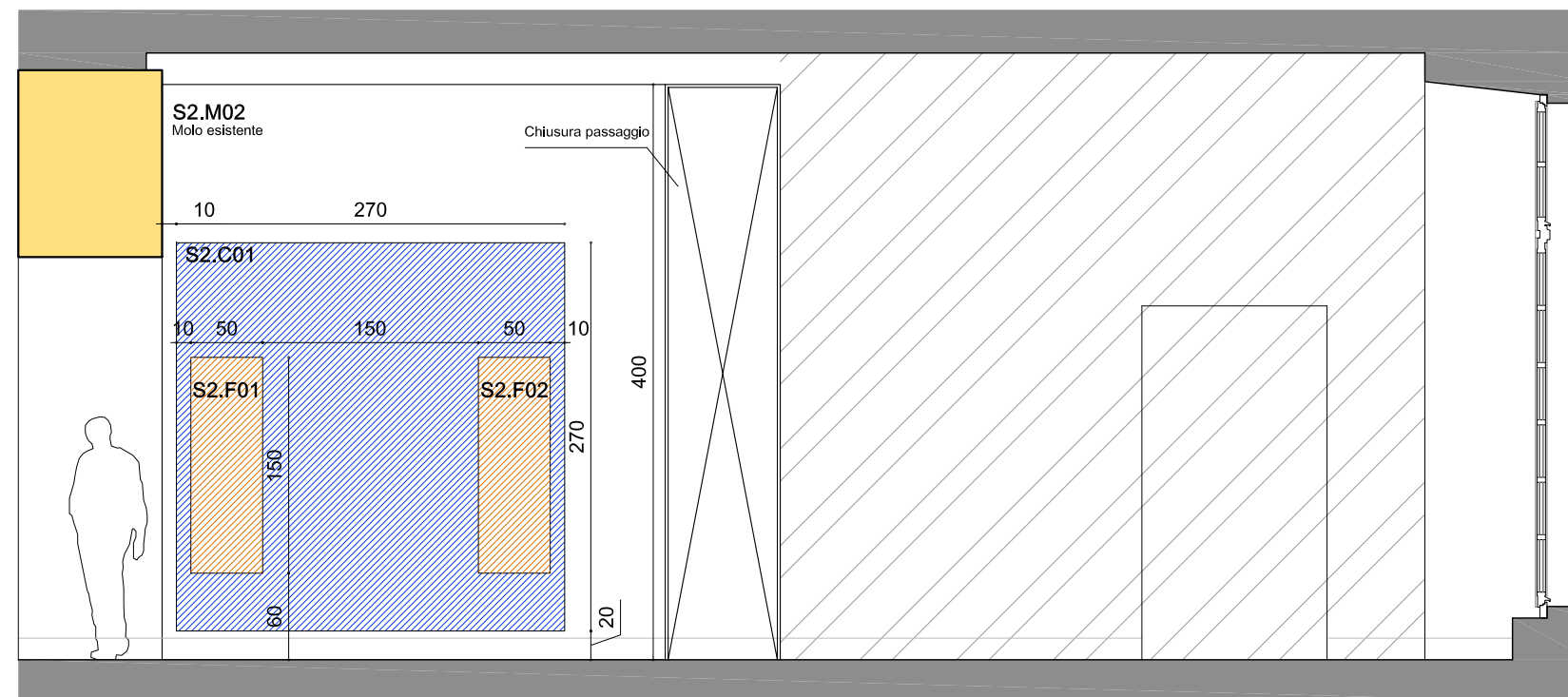

Parete 2

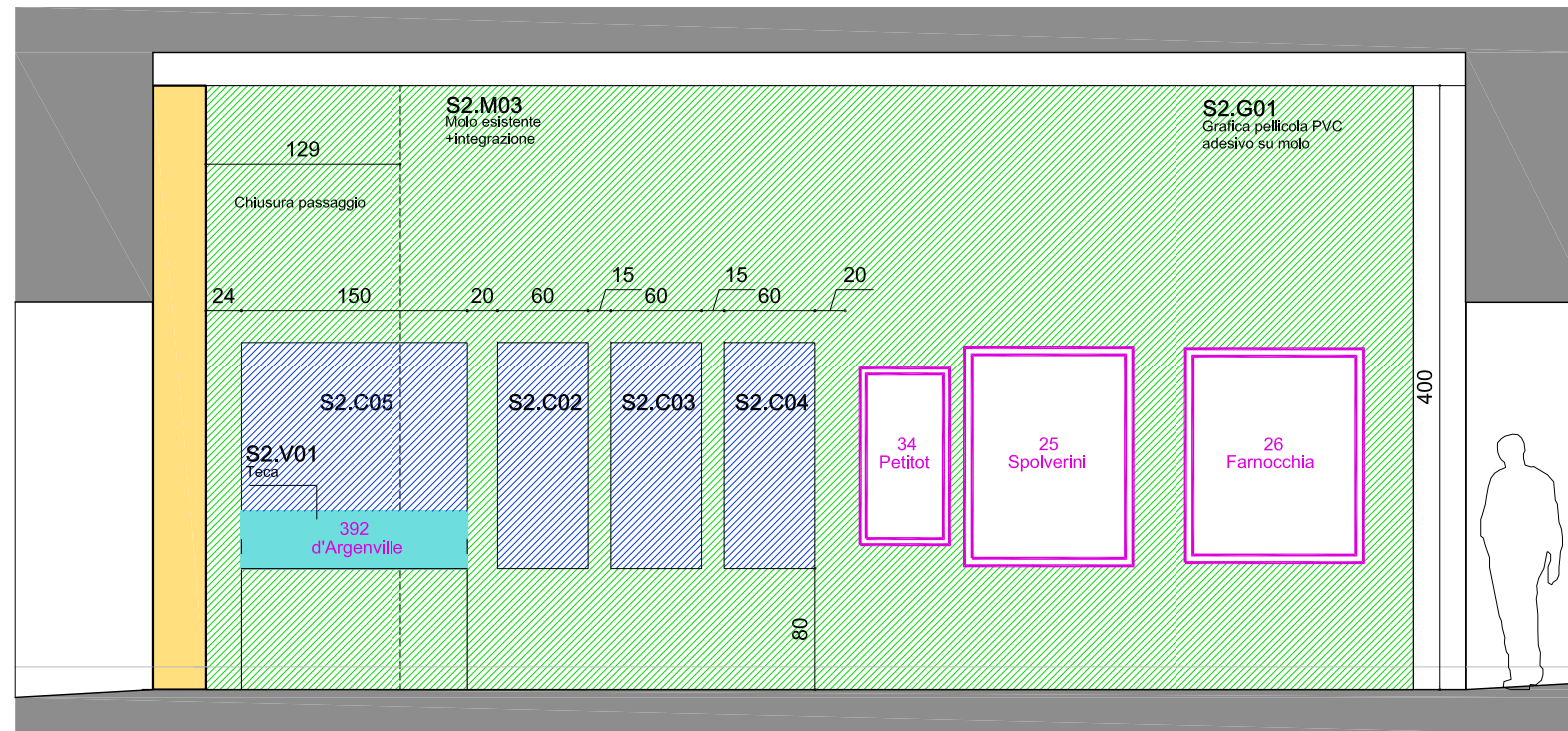

Parete 3

 PORZIONE NON OGGETTO DELLA PRESENTE SALA

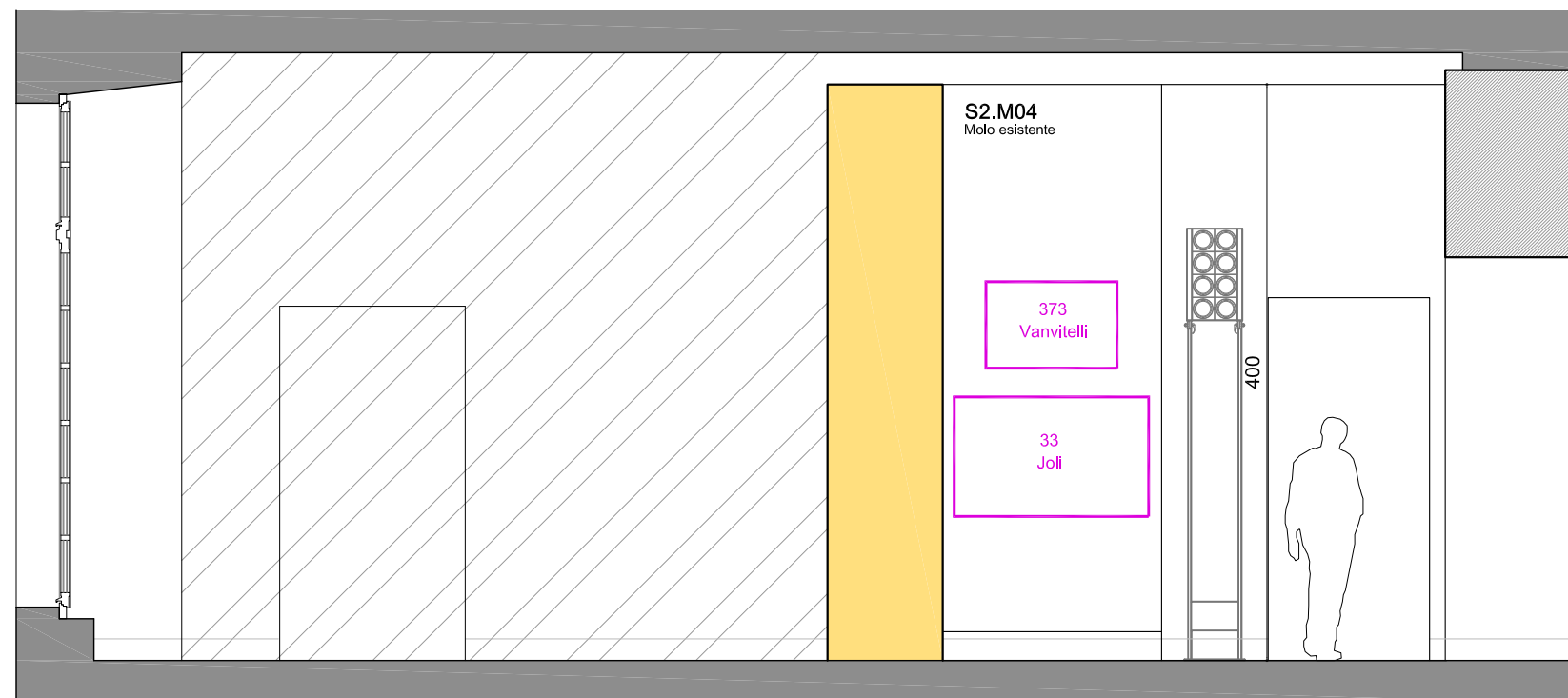

Parete 4

PART. 2
Fissaggio pannello in Piuma al canvas

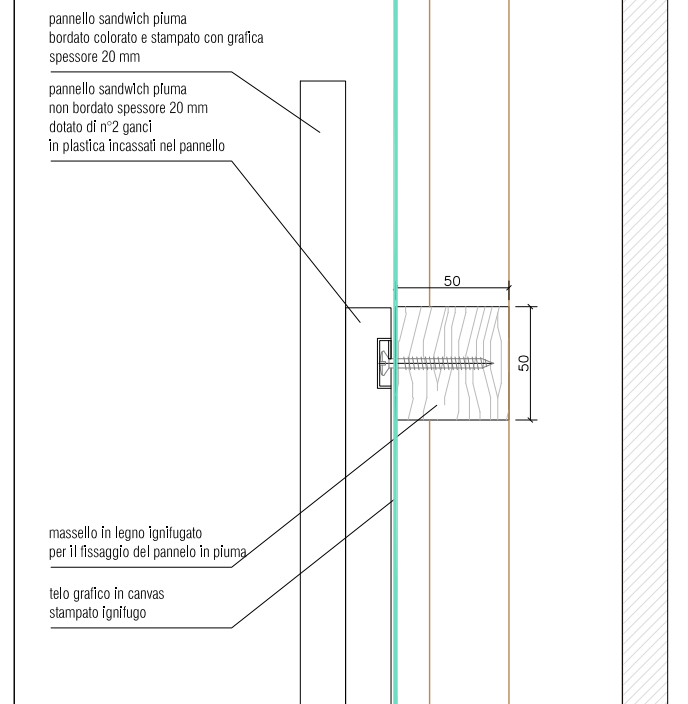

PART. 1
Fissaggio canvas alla parete in mdf del mofo

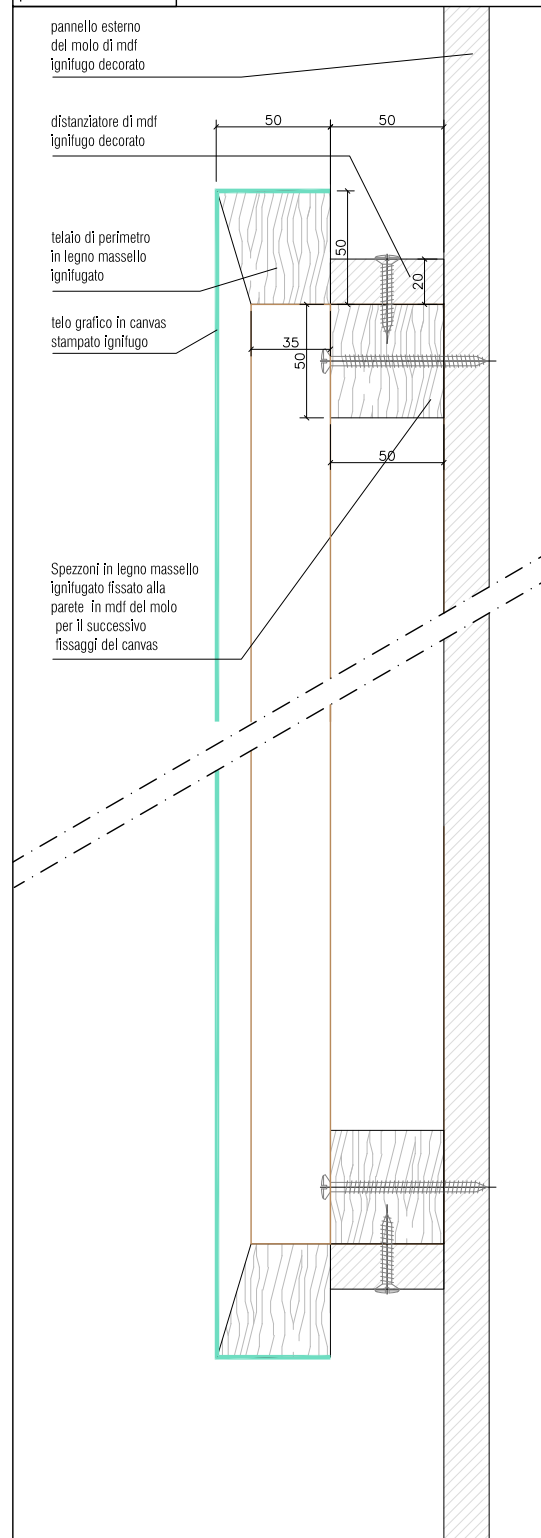

S2.C01
Telaio ligneo sparapuntato con telo grafico realizzato in masselli di legno ignifugato

S2.F01/F02
Doppio pannello in piuma spessore 20 mm

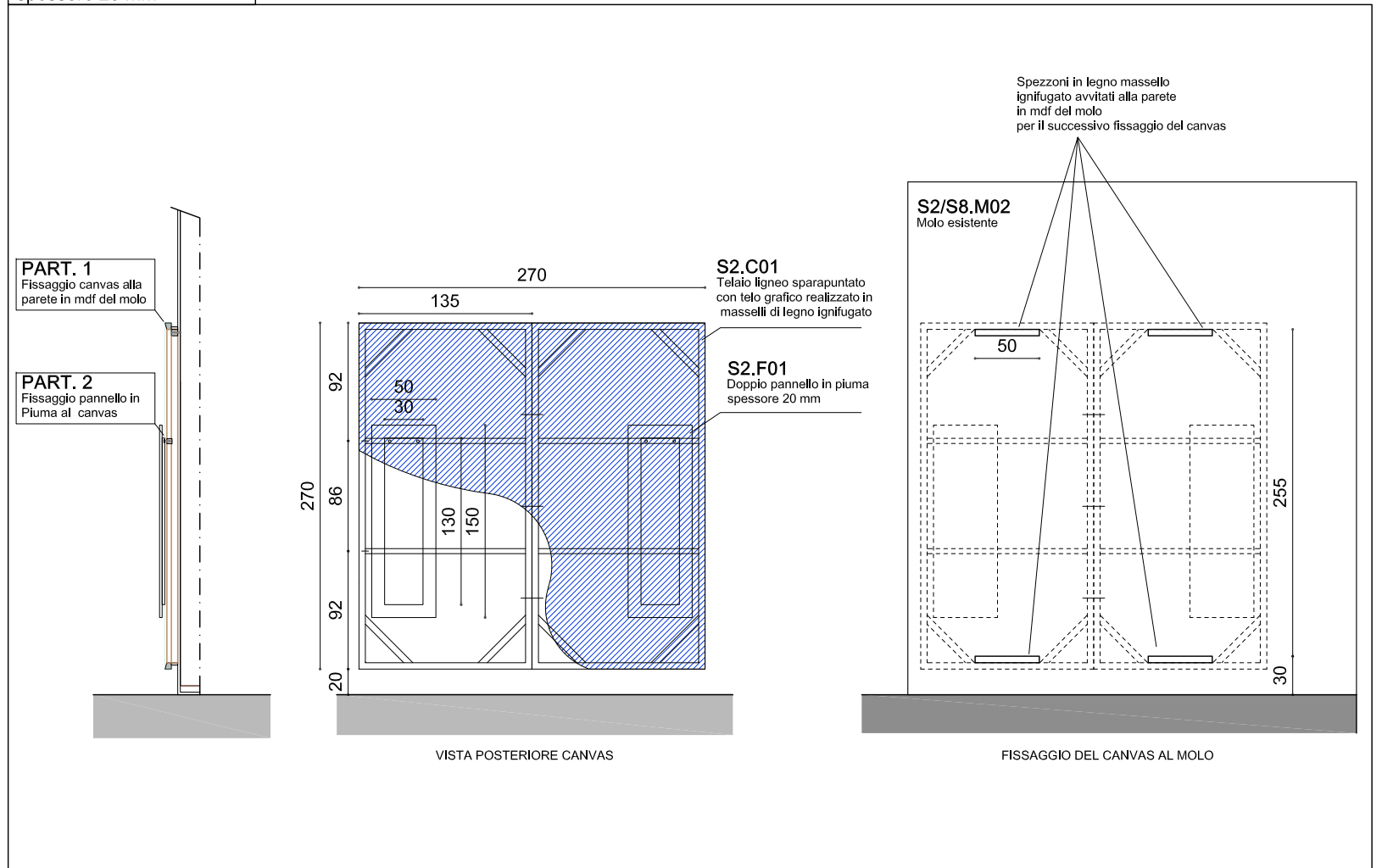

PART. 1
Fissaggio canvas alla parete in mdf del molo

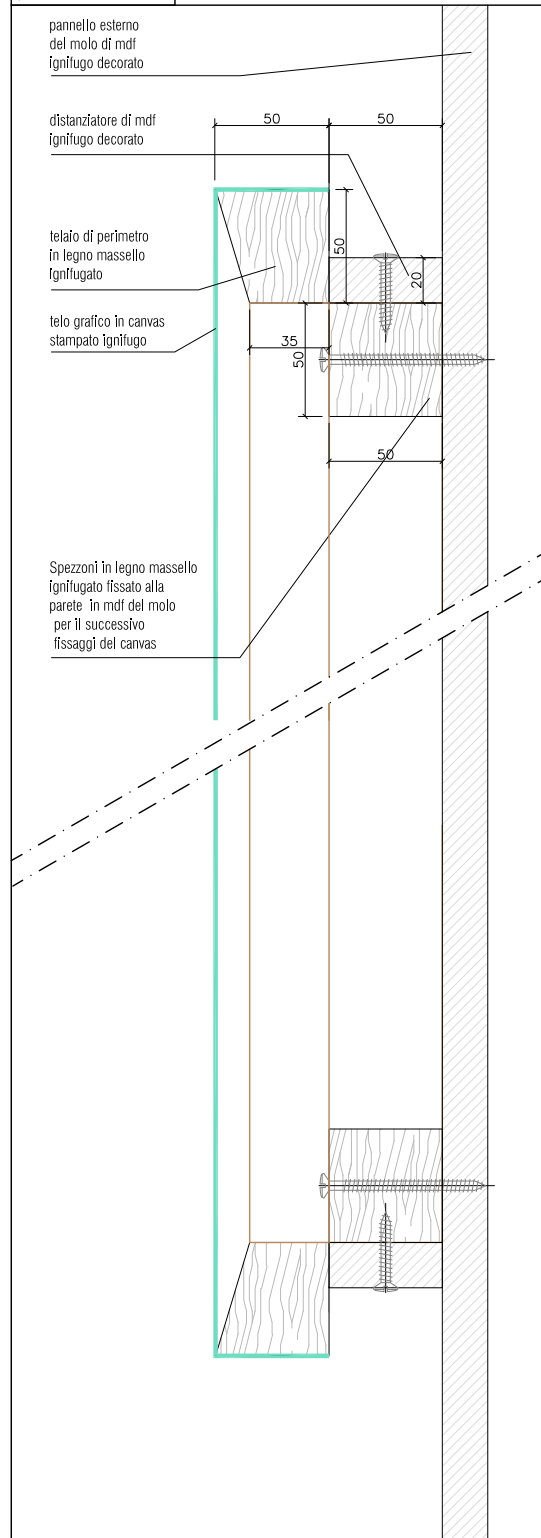

S2.C02/C03/C04
Telaio ligneo sparapuntato con telo grafico realizzato in masselli di legno ignifugato

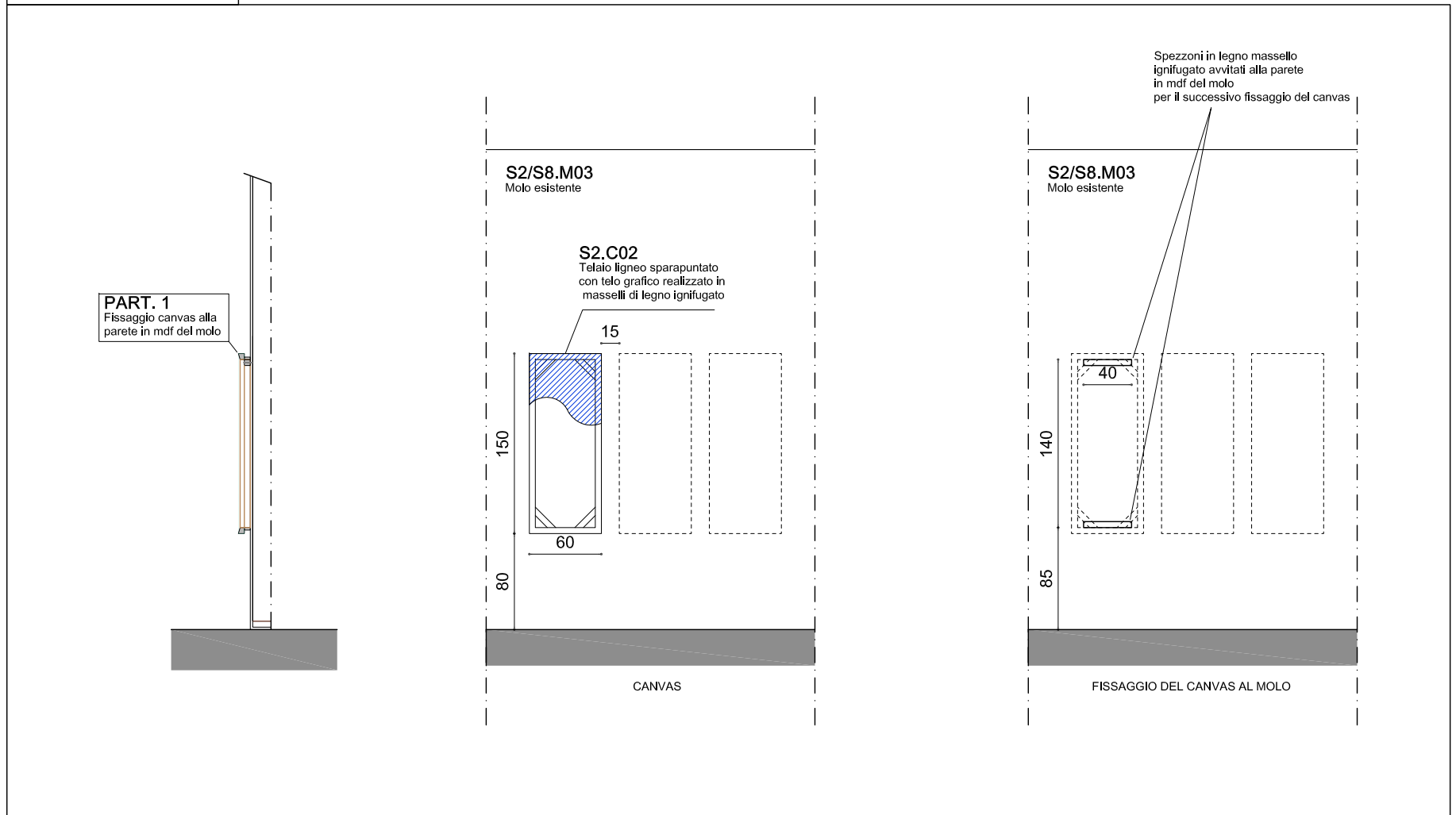

PART. 1
Fissaggio canvas alla parete in mdf del molo

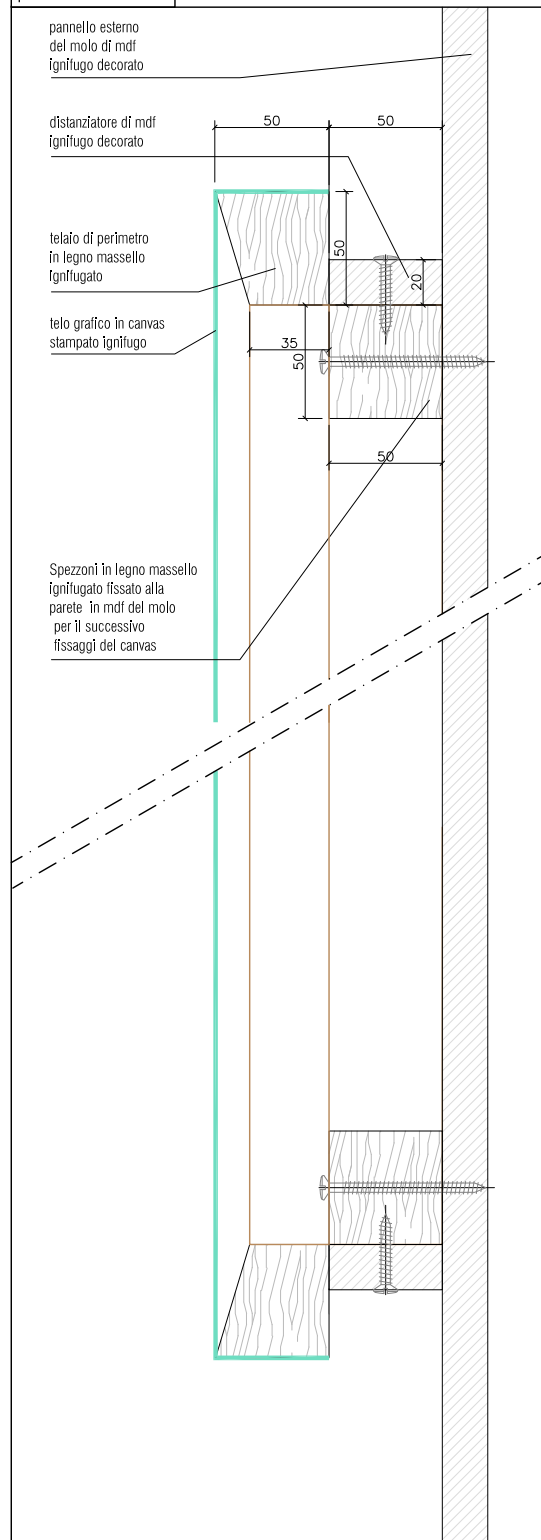

S2.05
Telaio ligneo sparapuntato con telo grafico realizzato in masselli di legno ignifugato

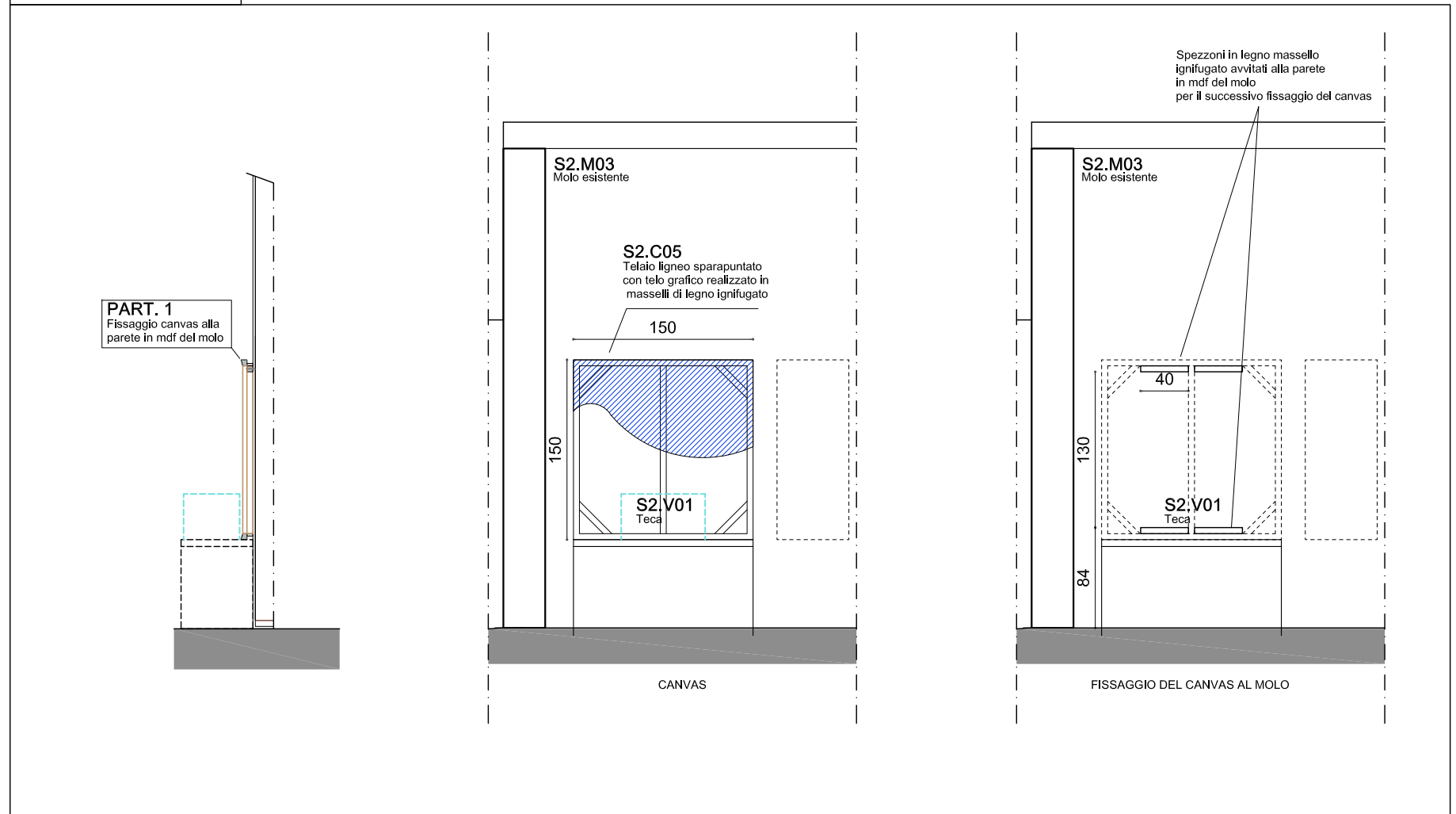

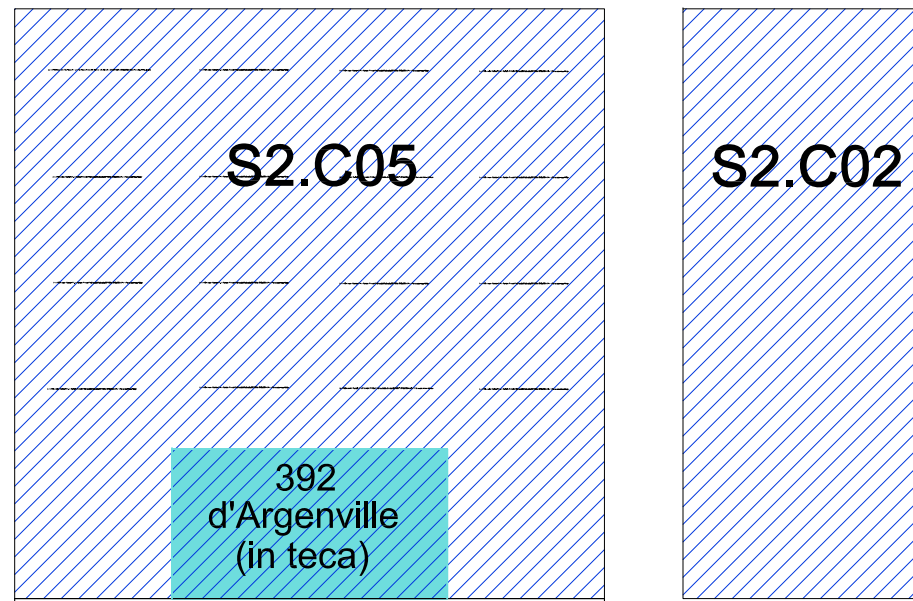

PROSPETTO FRONTALE

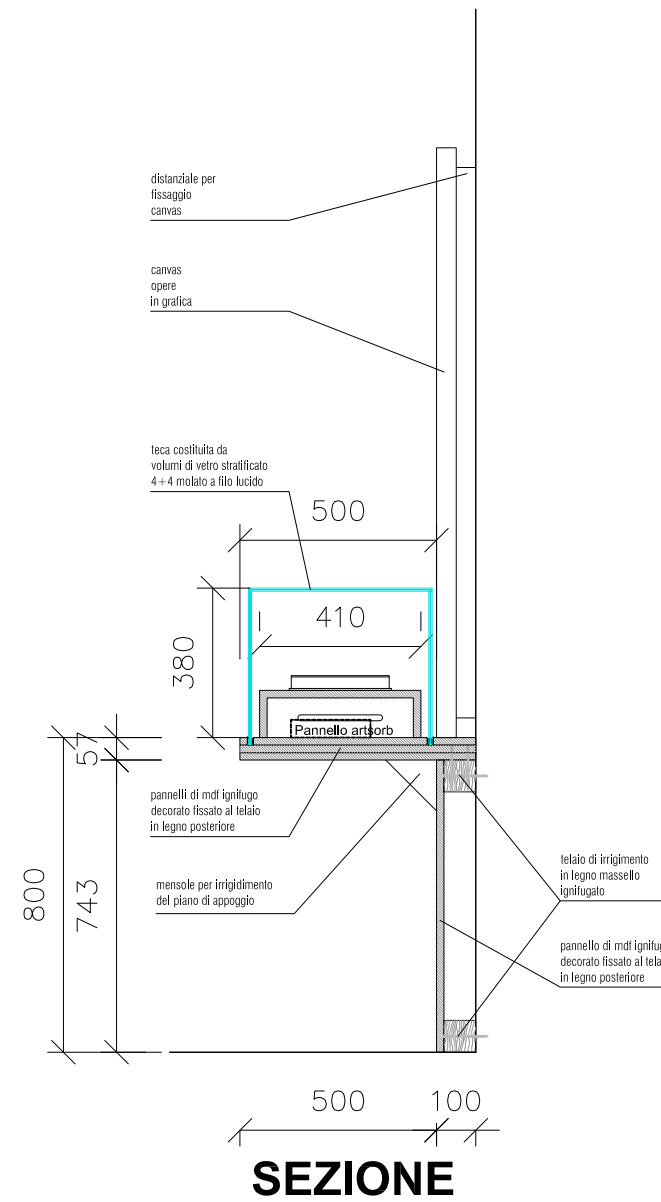

SEZIONE

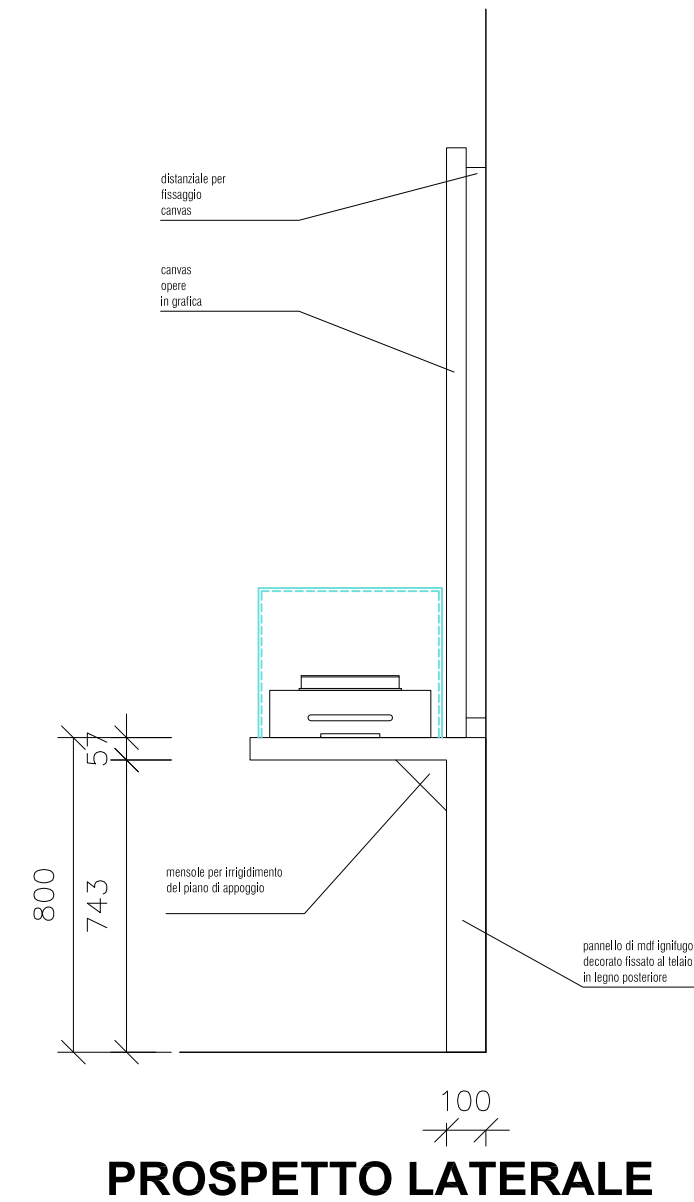

PROSPETTO LATERALE

DETTAGLIO SIGILLATURA VETRI

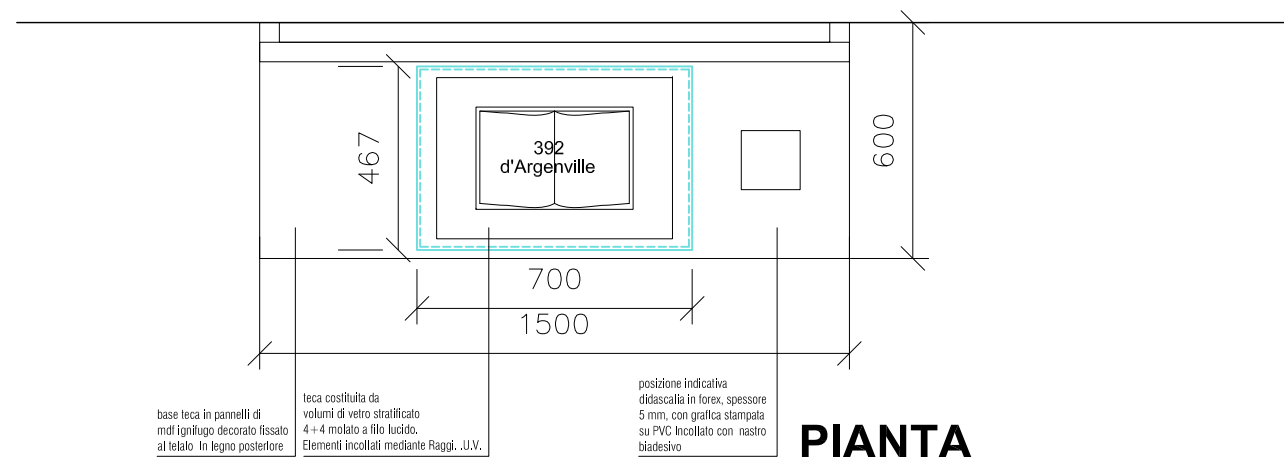
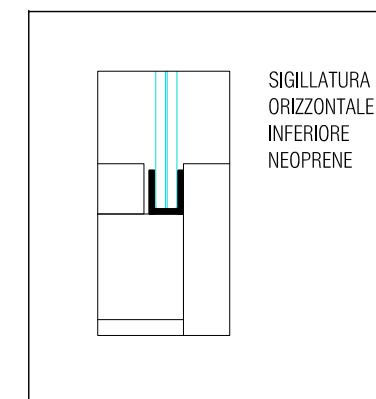

PIANTA

S2.V01
Teca

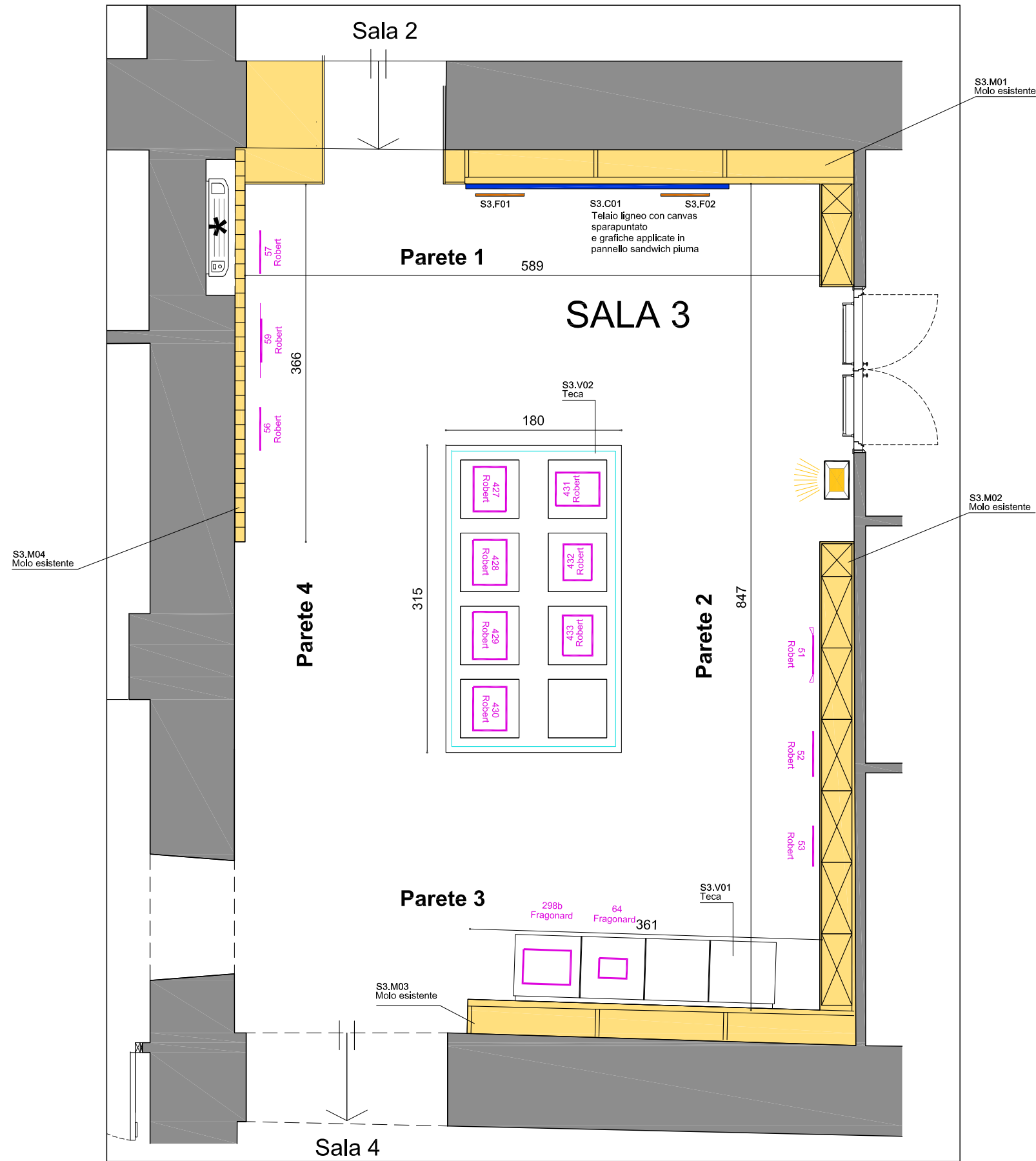

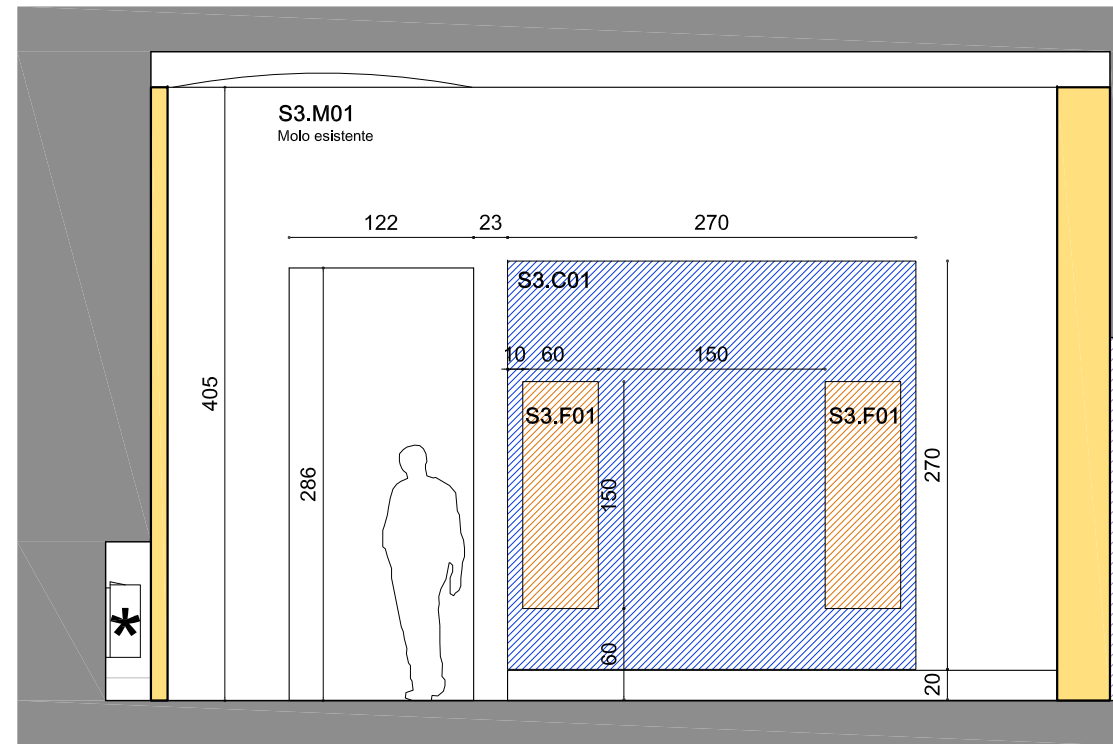

Parete 1

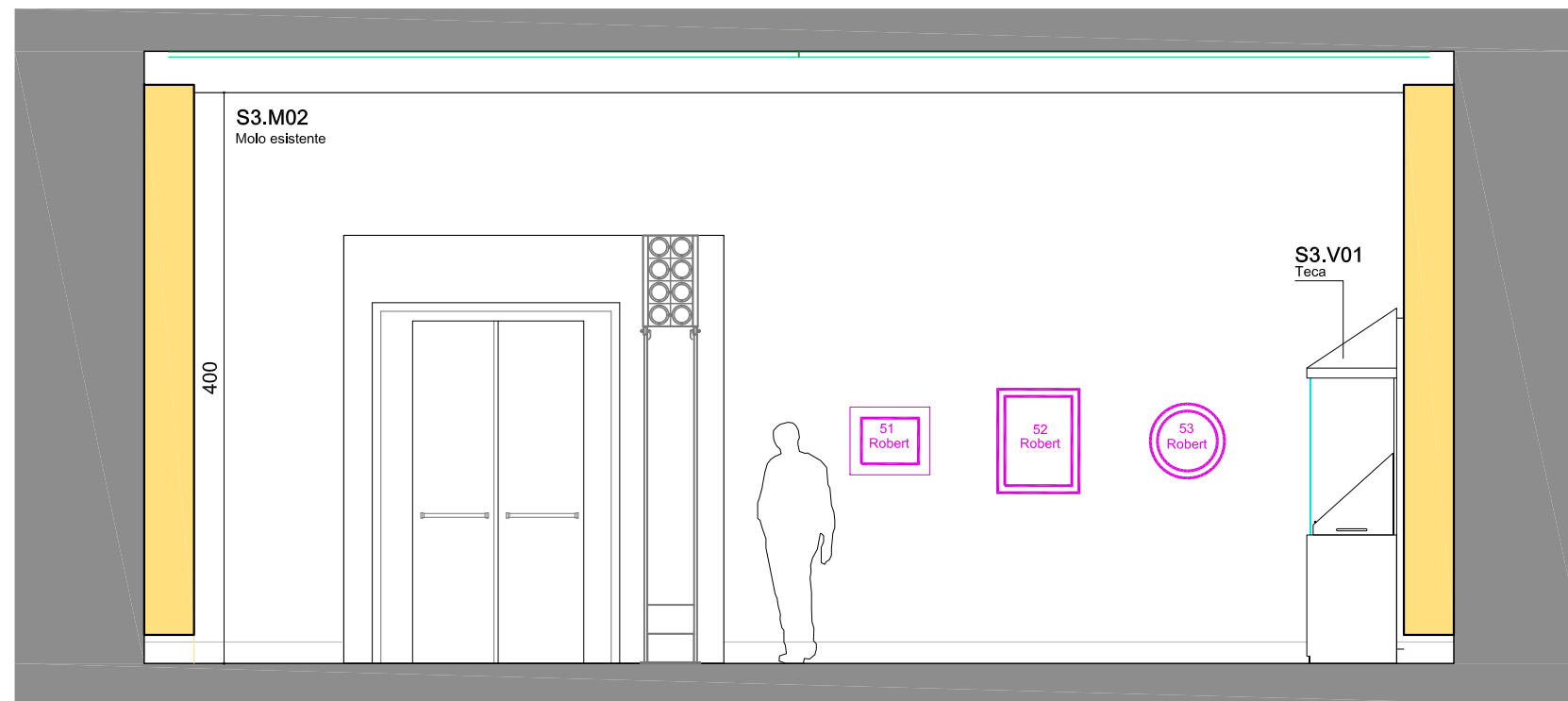

Parete 2

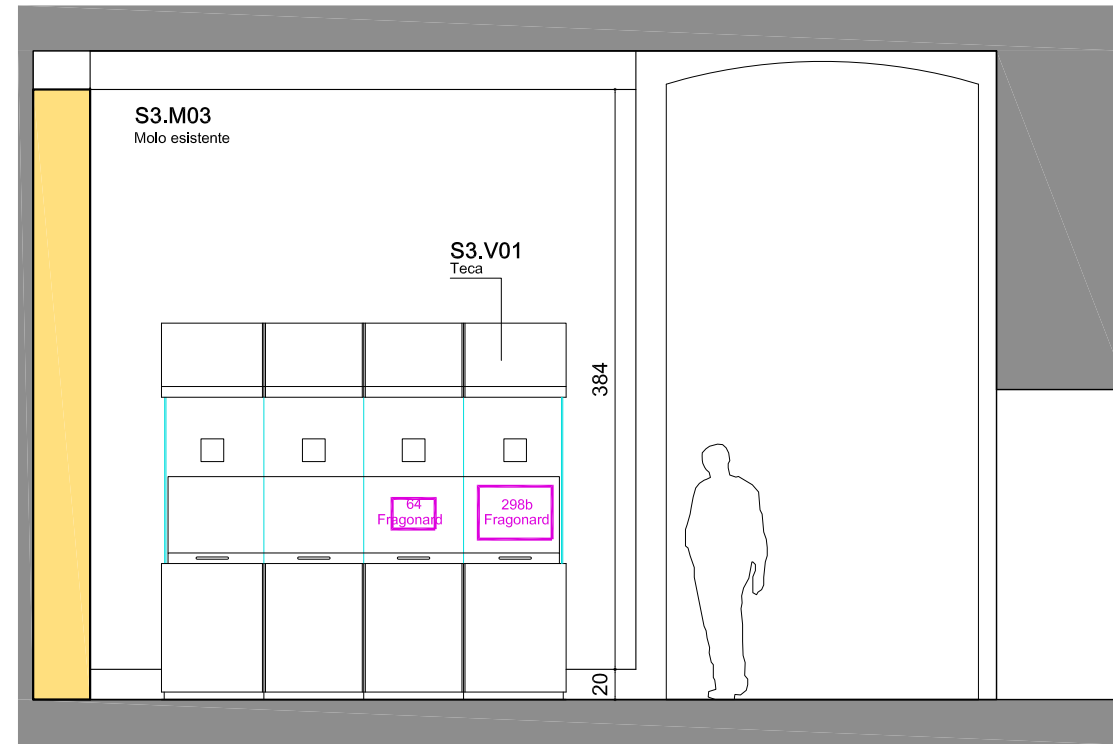

Parete 3



Parete 4

PART. 2
Fissaggio pannello in Piuma al canvas

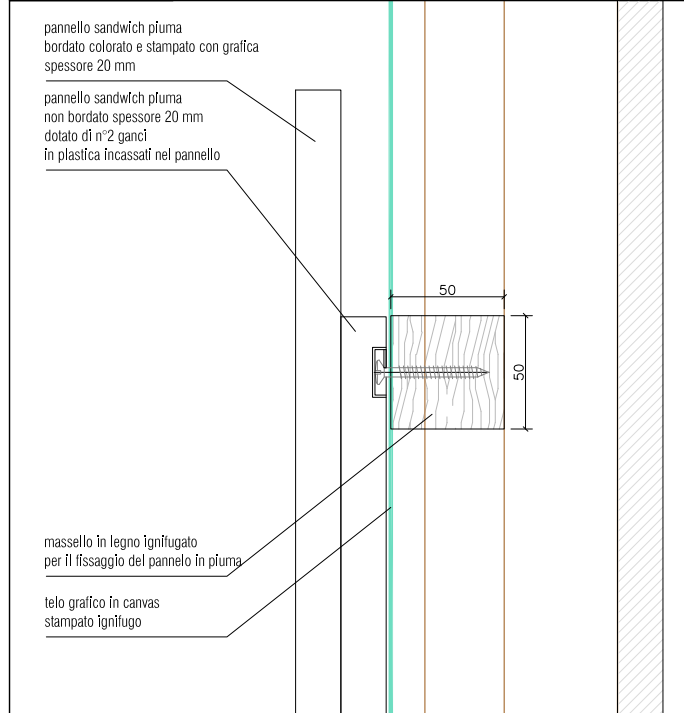

PART. 1
Fissaggio canvas alla parete in mdf del molo

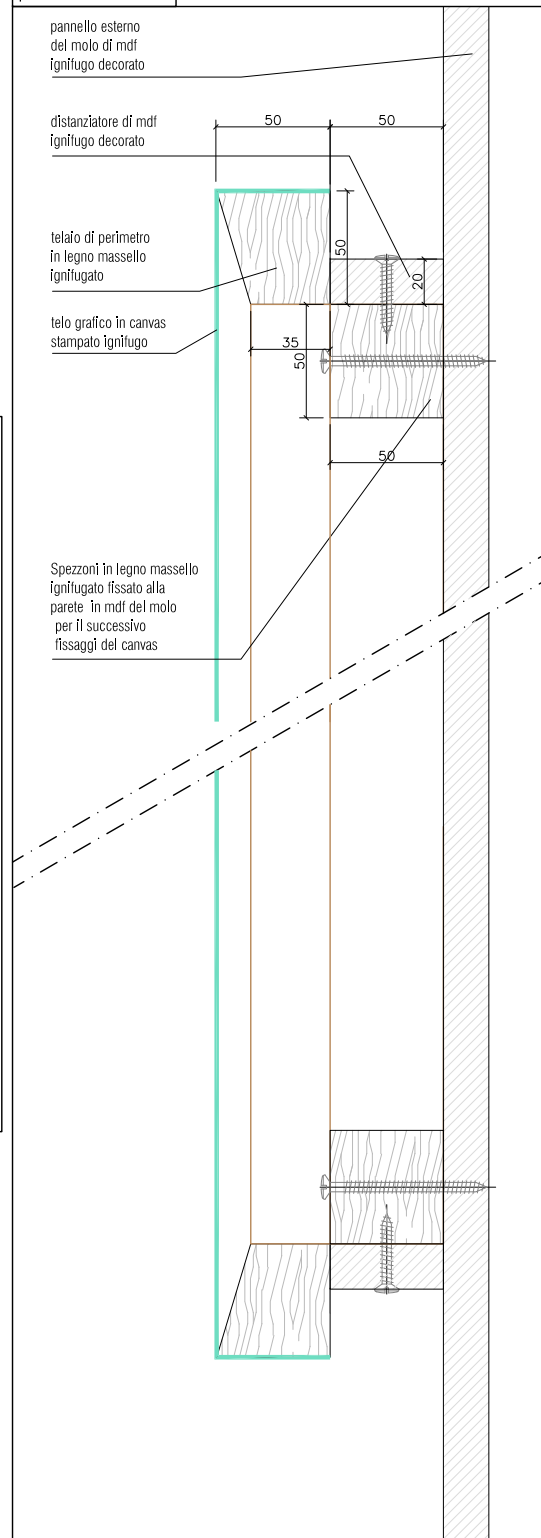

S3.C01
Telaio ligneo sparapuntato con telo grafico realizzato in masselli di legno ignifugato

S3.F01/F02
Doppio pannello in piuma spessore 20 mm

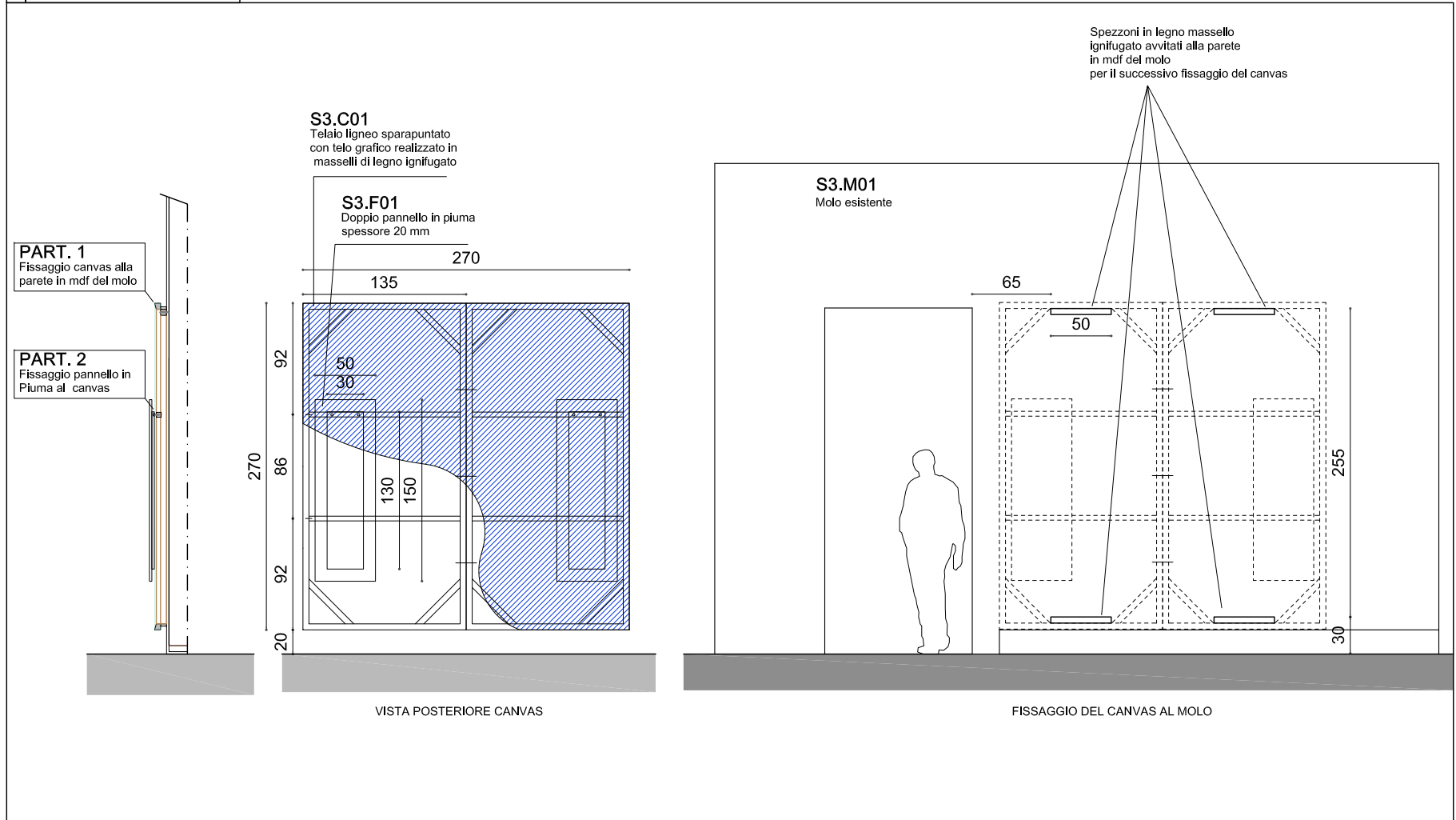

PIANTA C

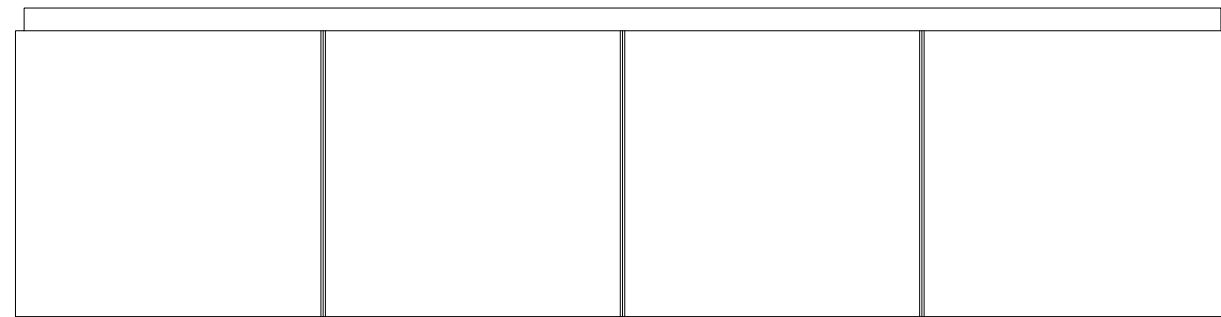

PIANTA B

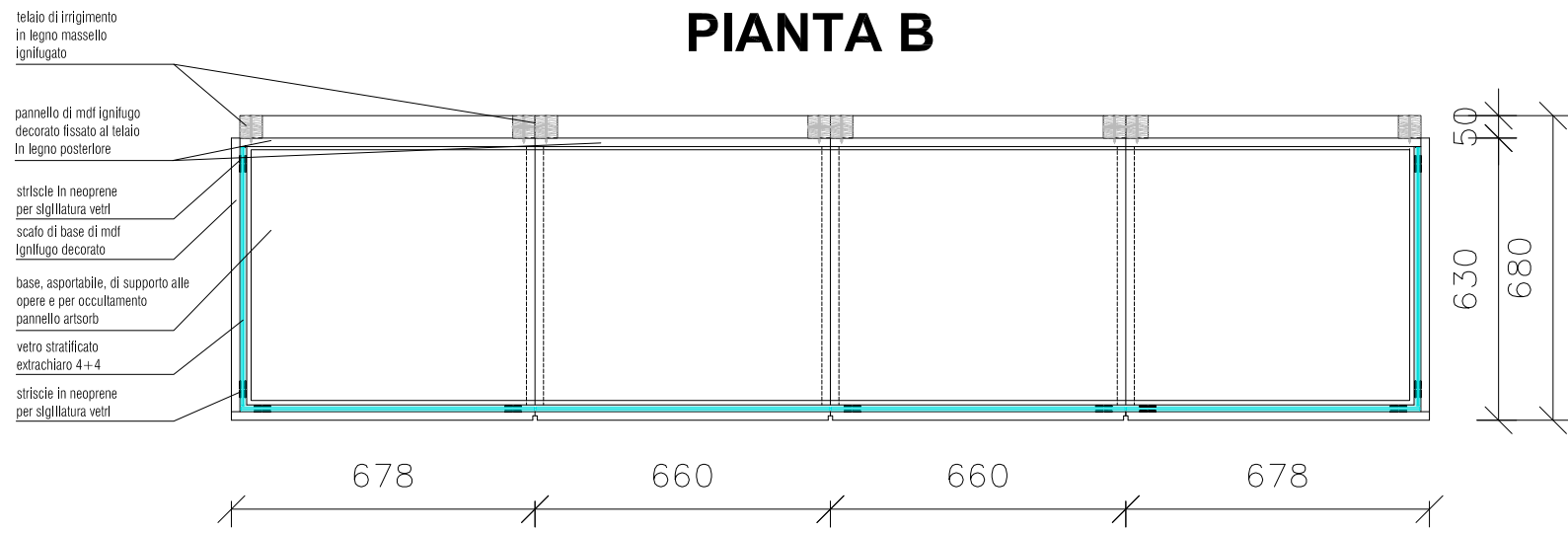

PIANTA A

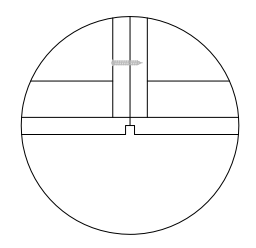
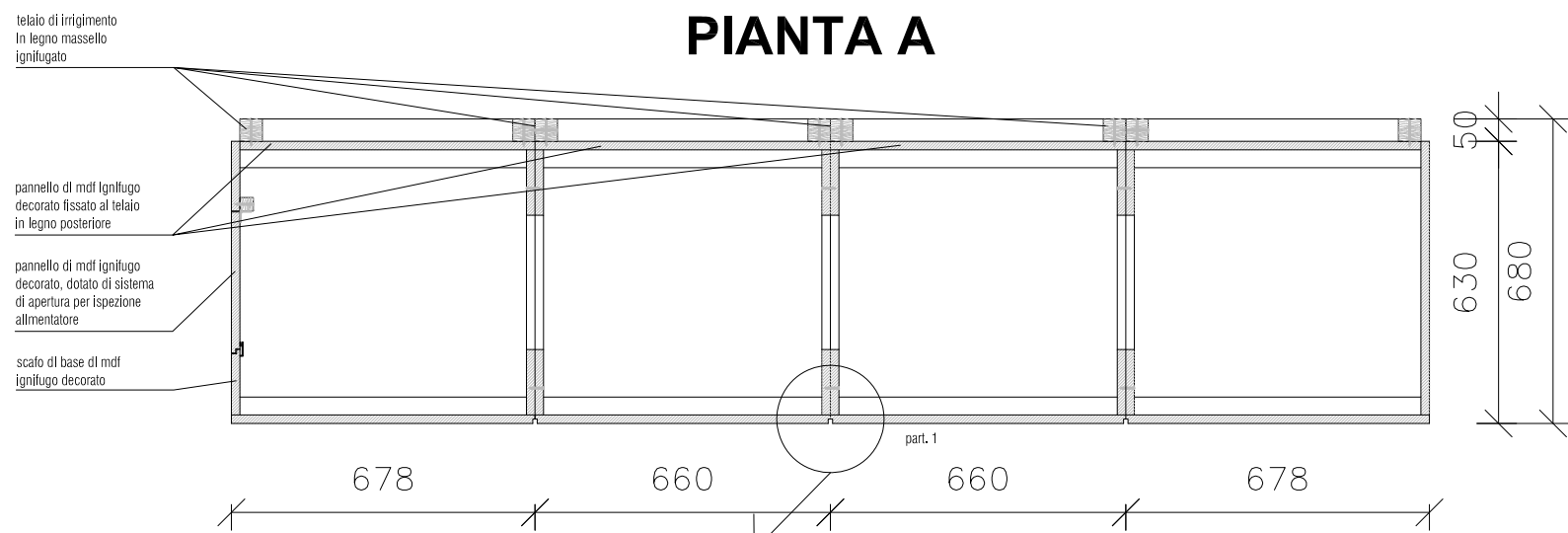

D

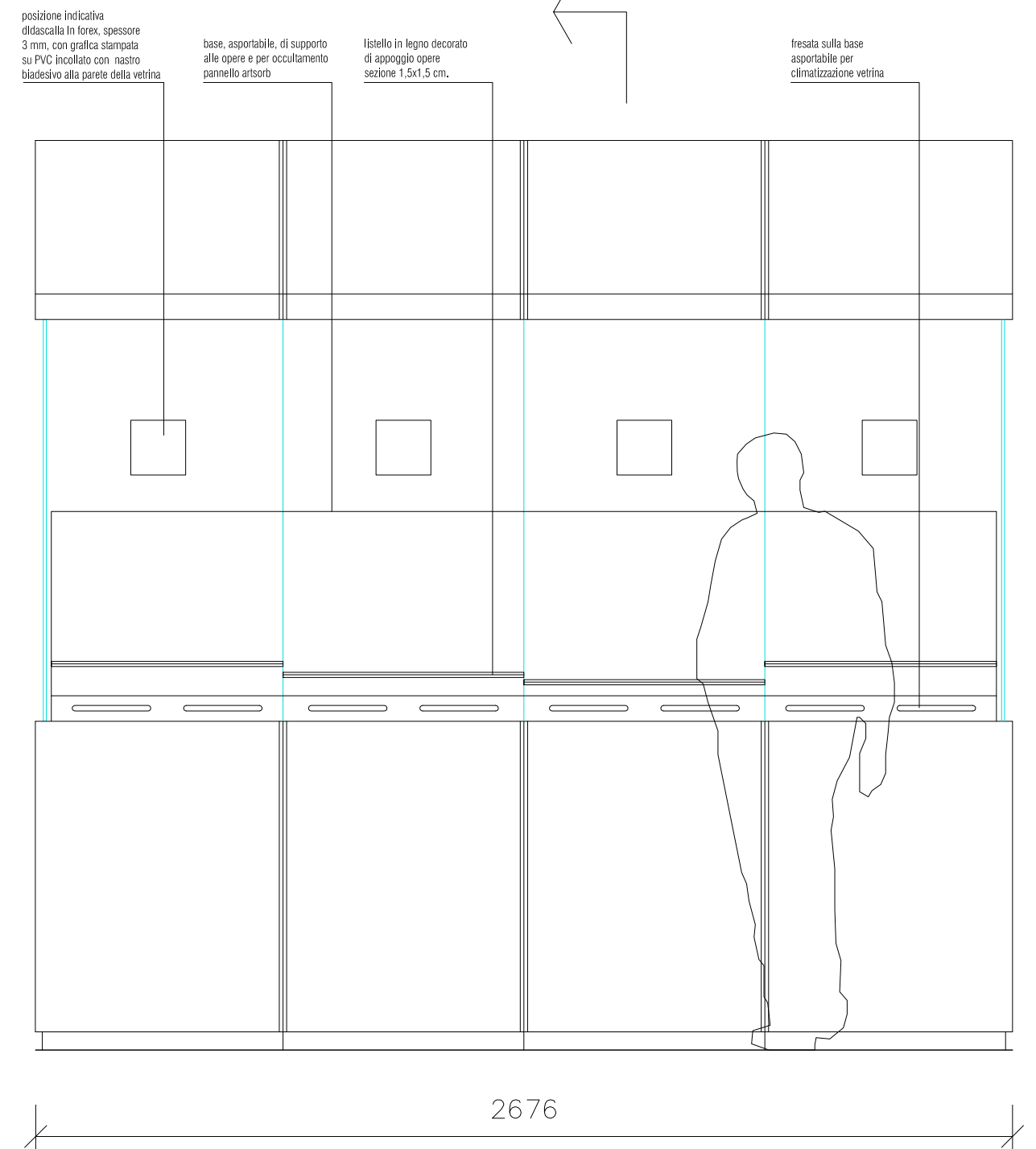

PROSPETTO FRONTALE

S3.V01
Teca

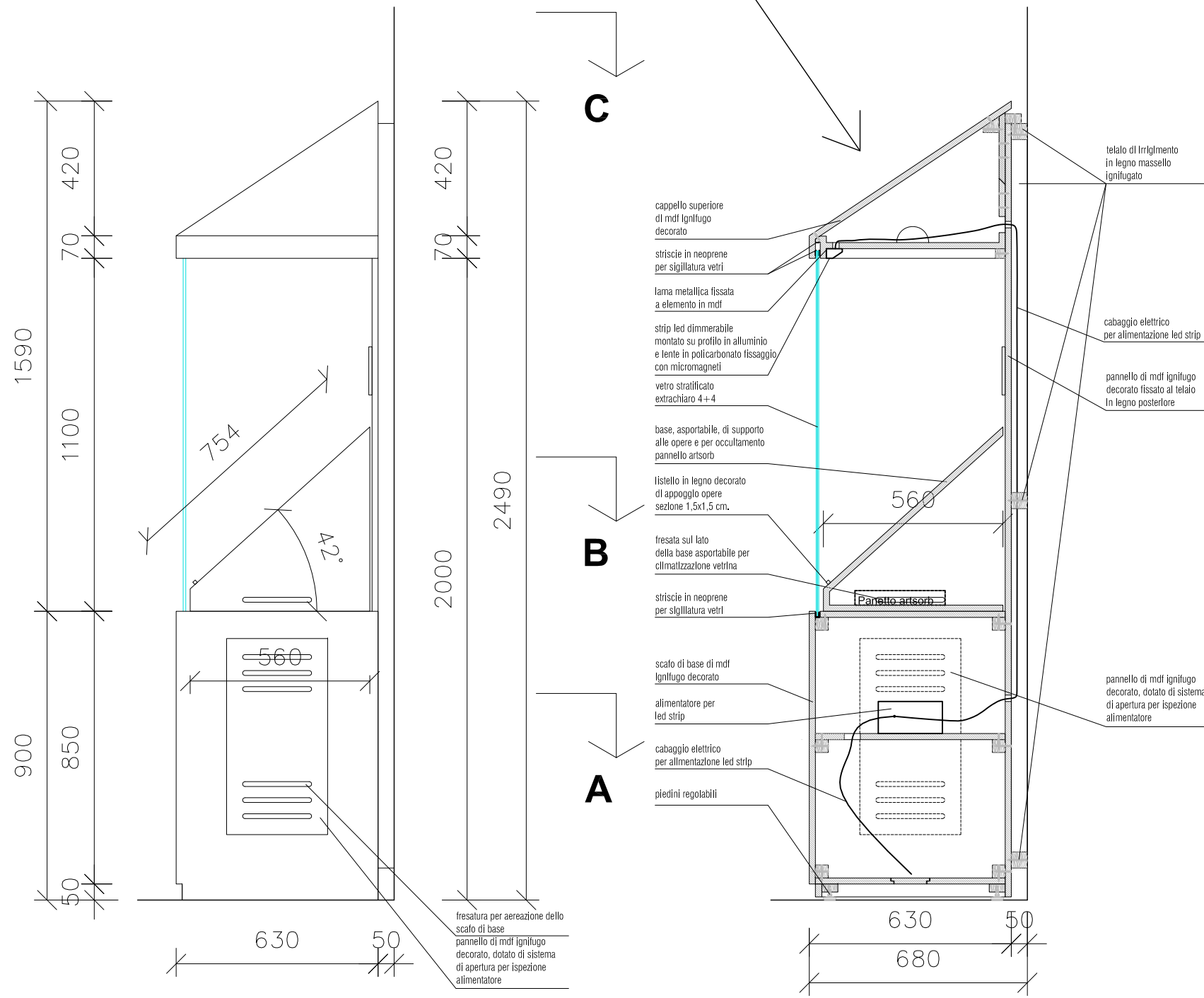
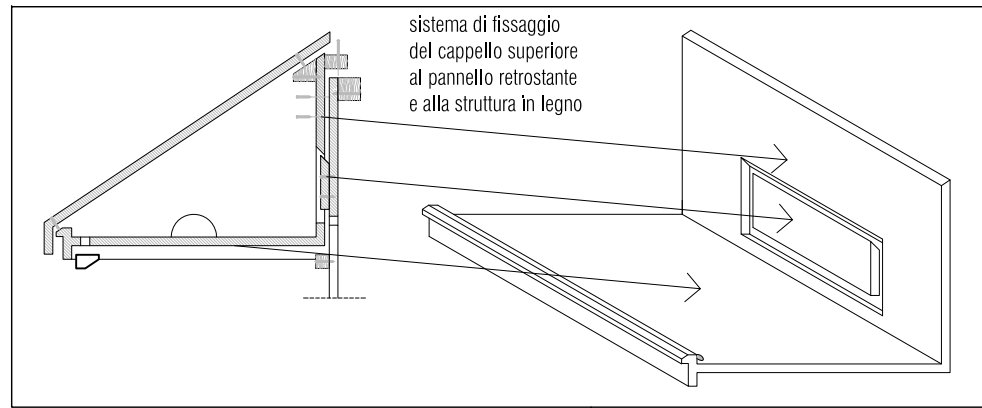

DETTAGLIO SIGILLATURA VETRI

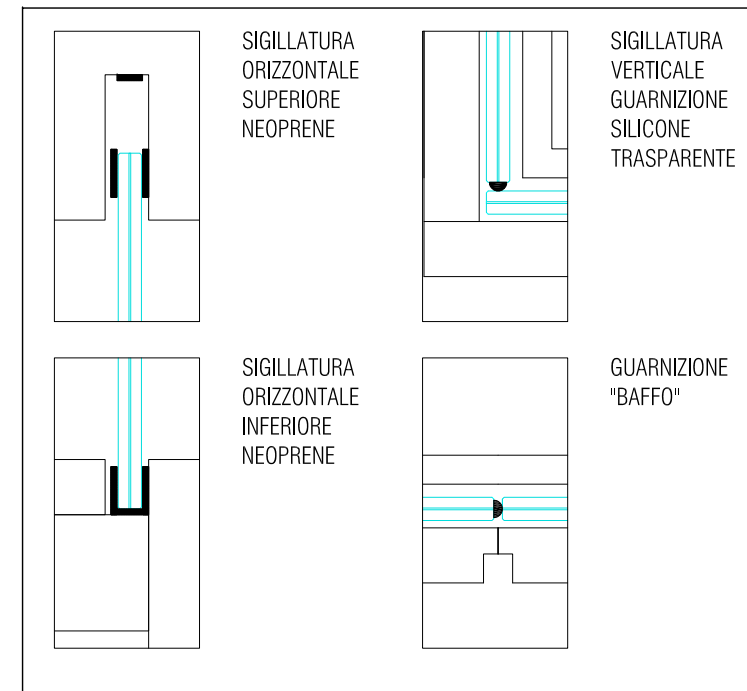

PROSPETTO LATERALE

SEZIONE D

S3.V01
Teca

PIANTA

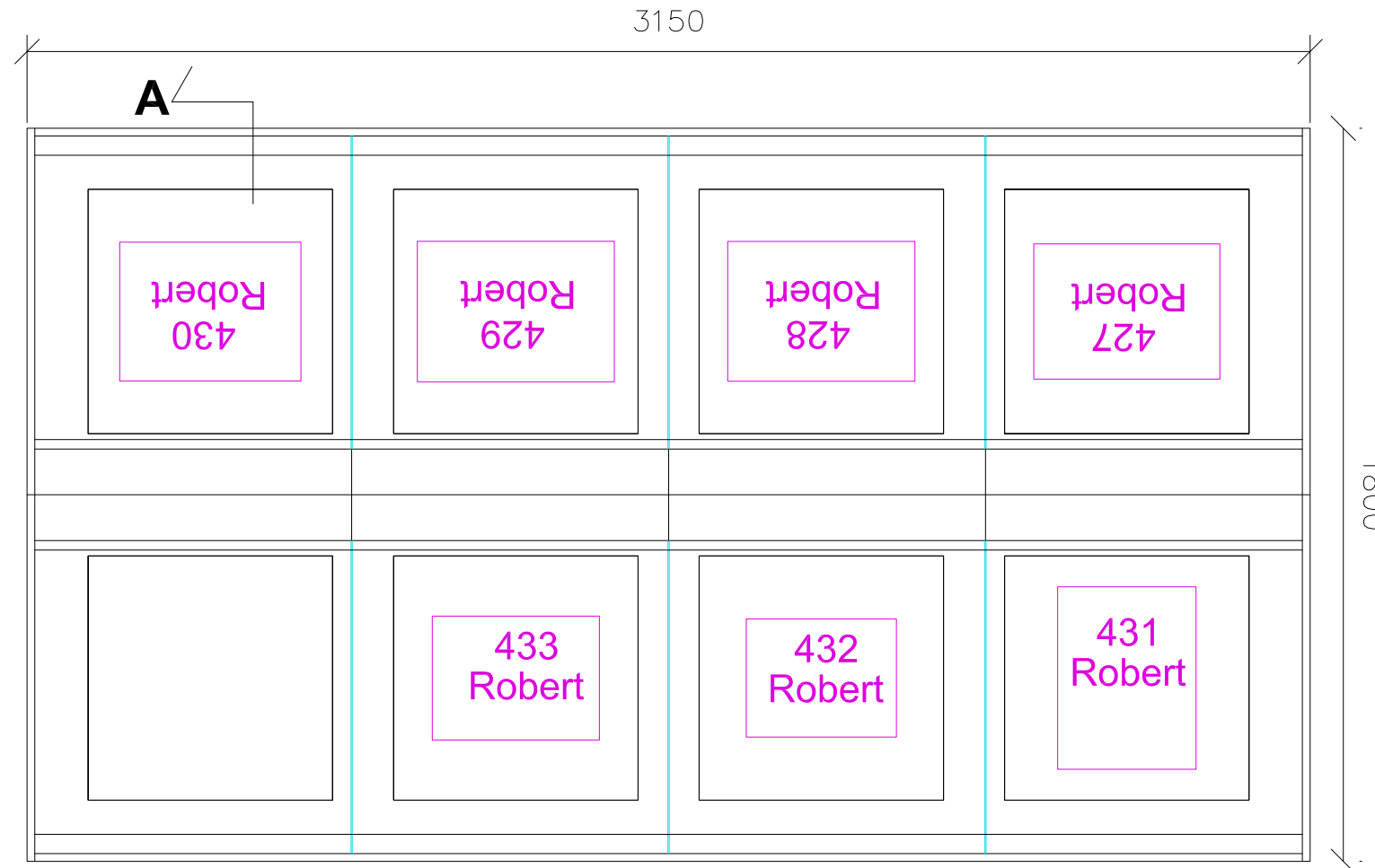

PROSPETTO FRONTALE

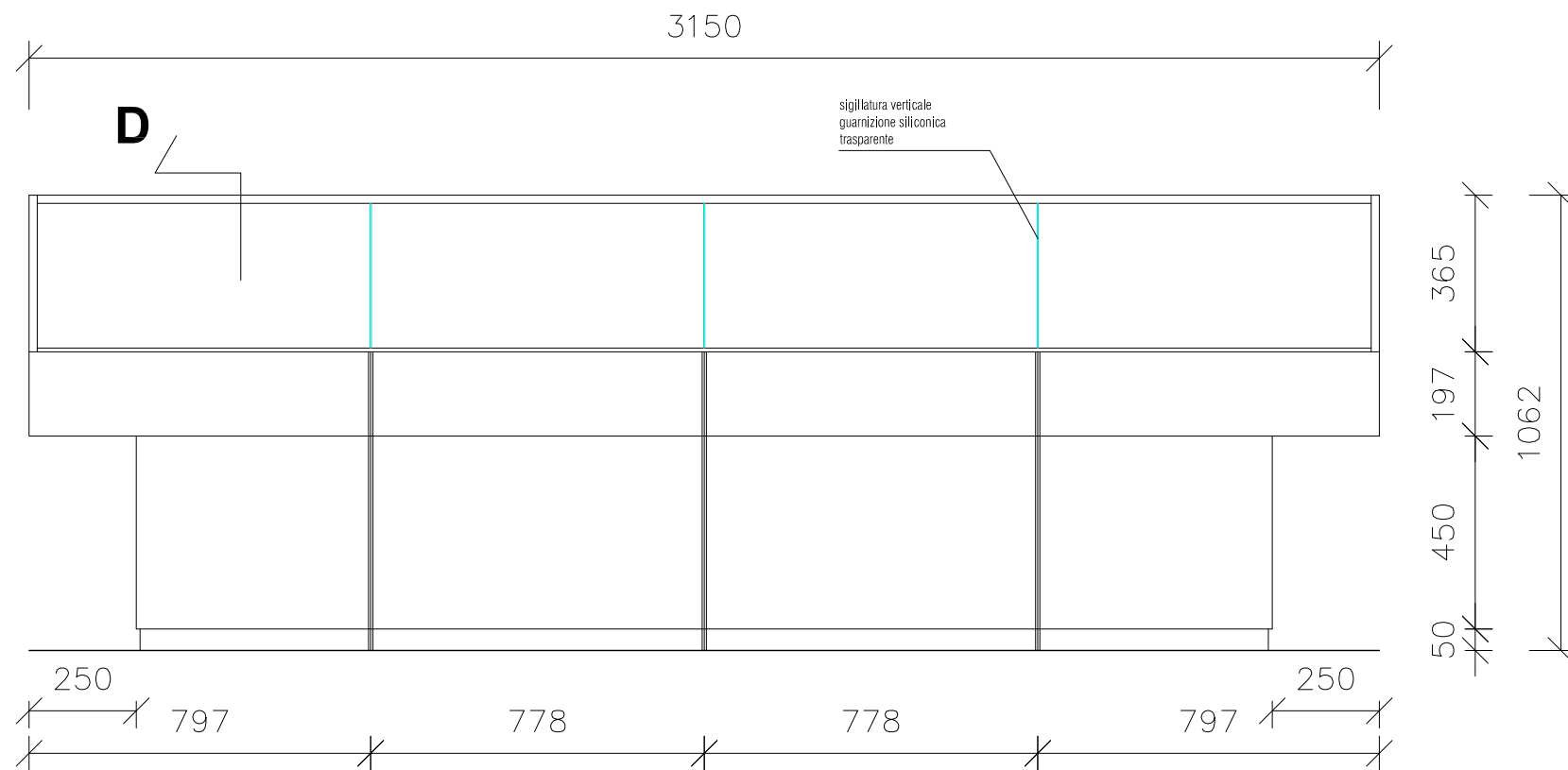

S3.V02
Teca

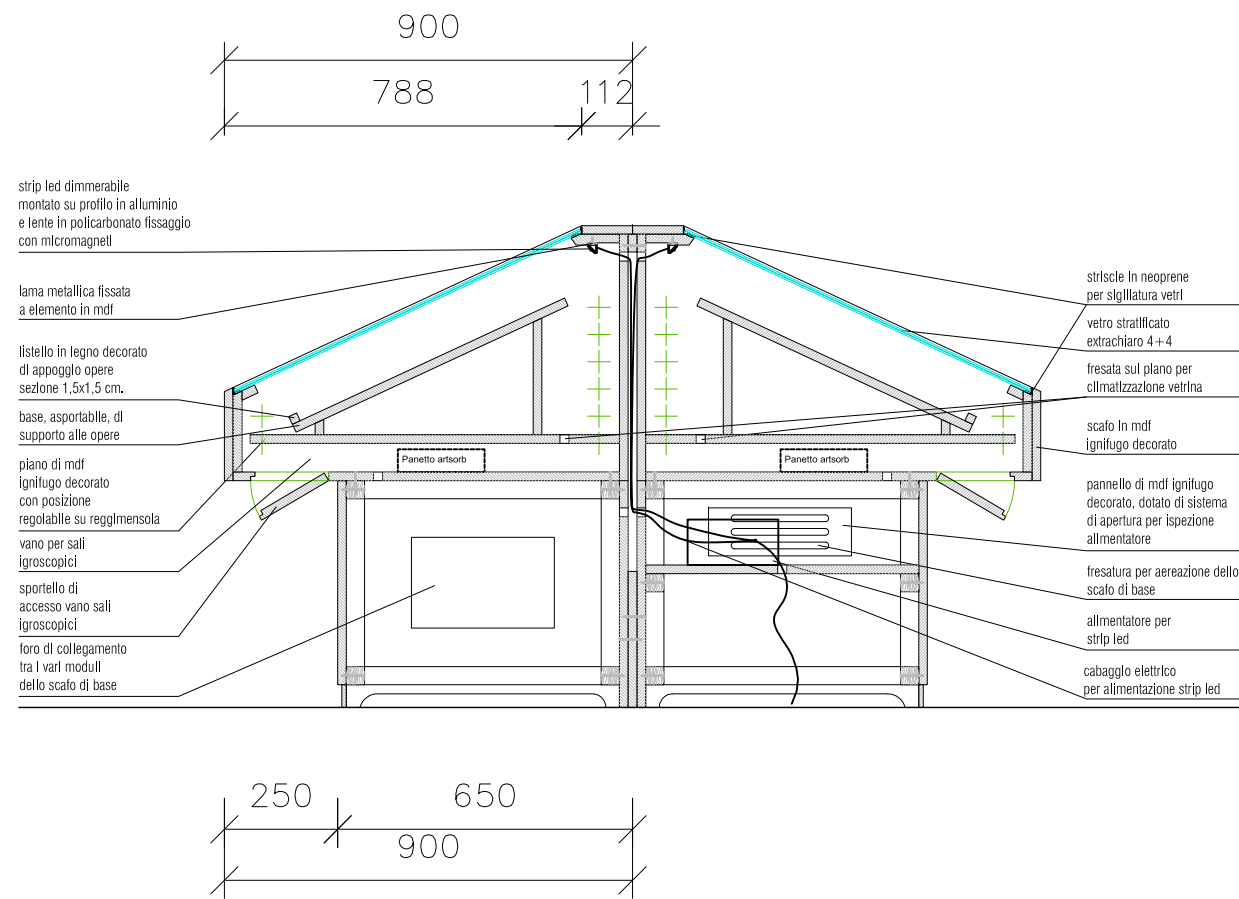

SEZIONE A

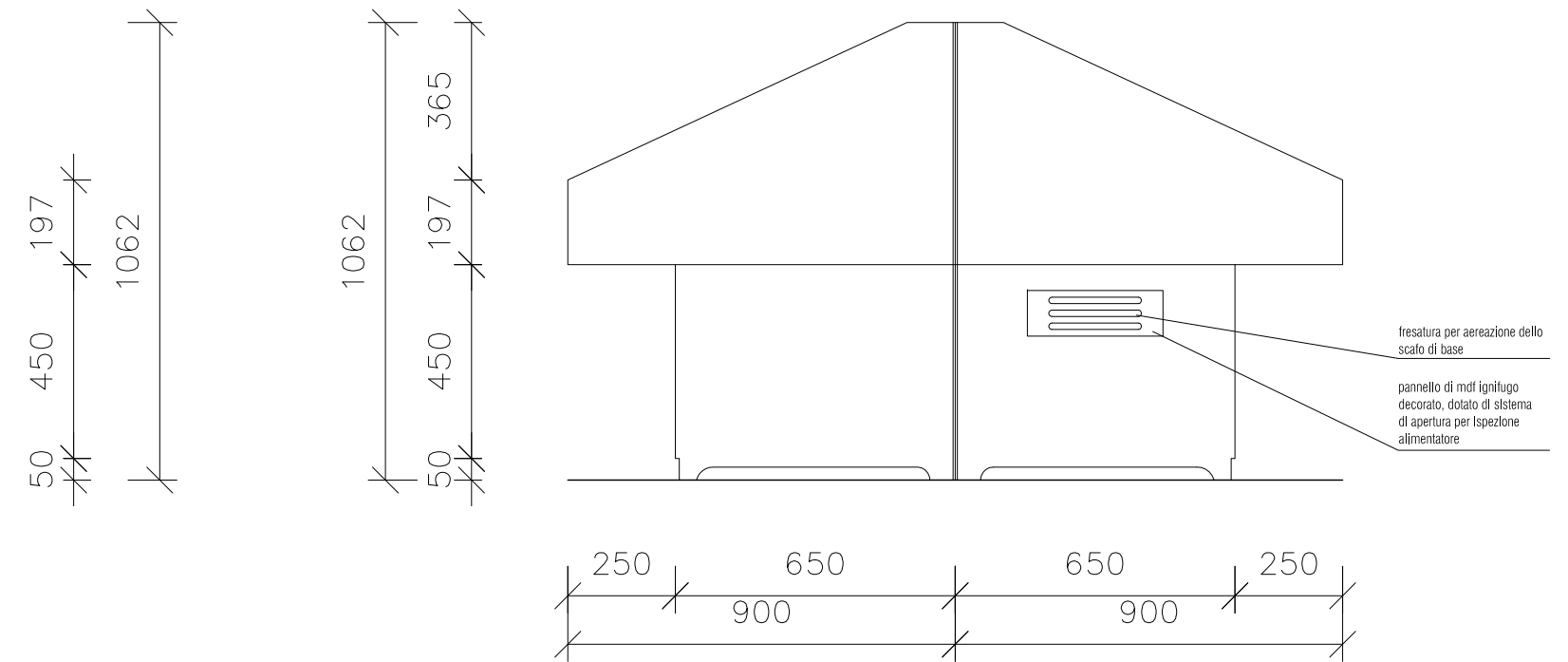

PROSPETTO LATERALE

S3.V02
Teca

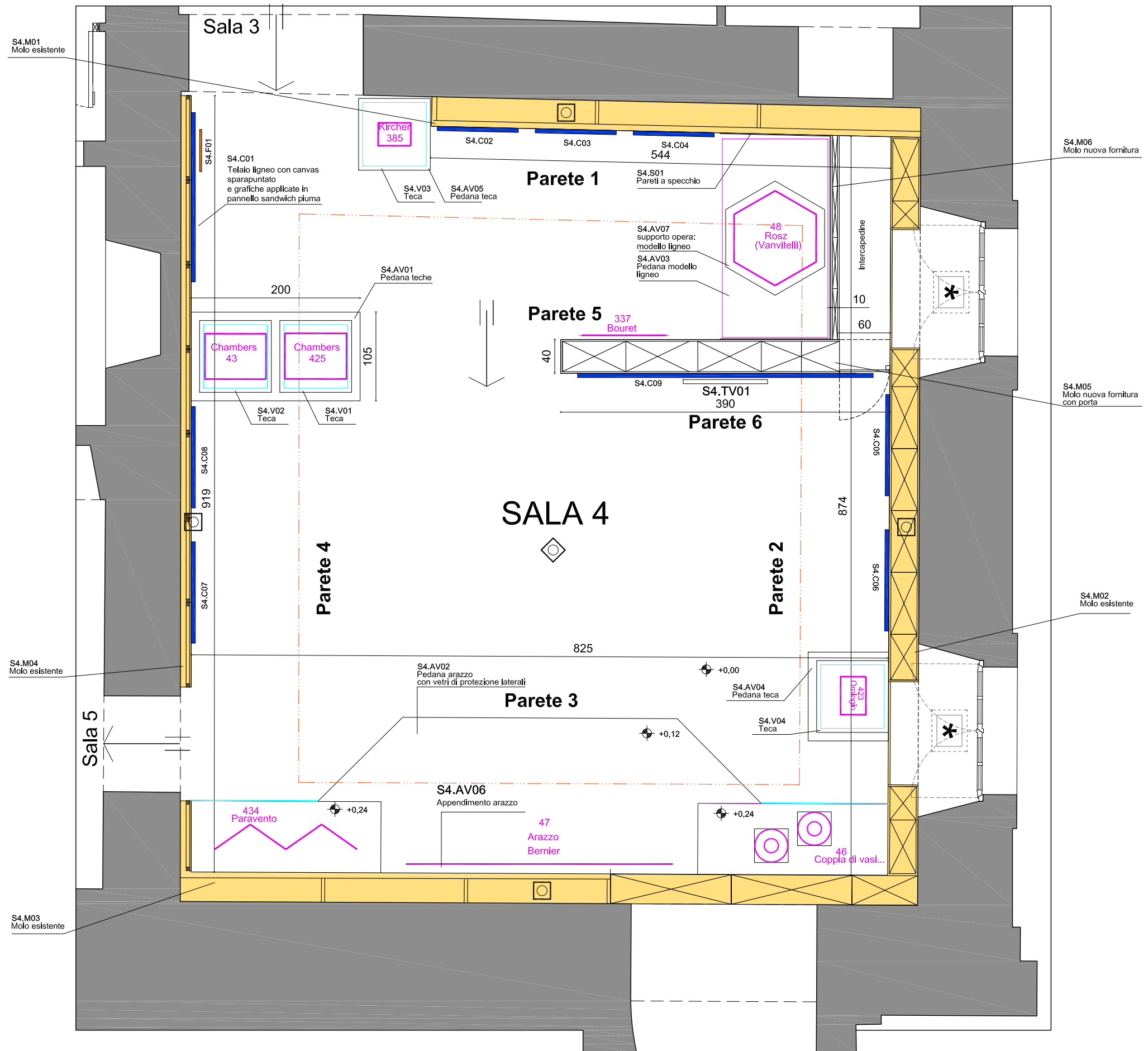

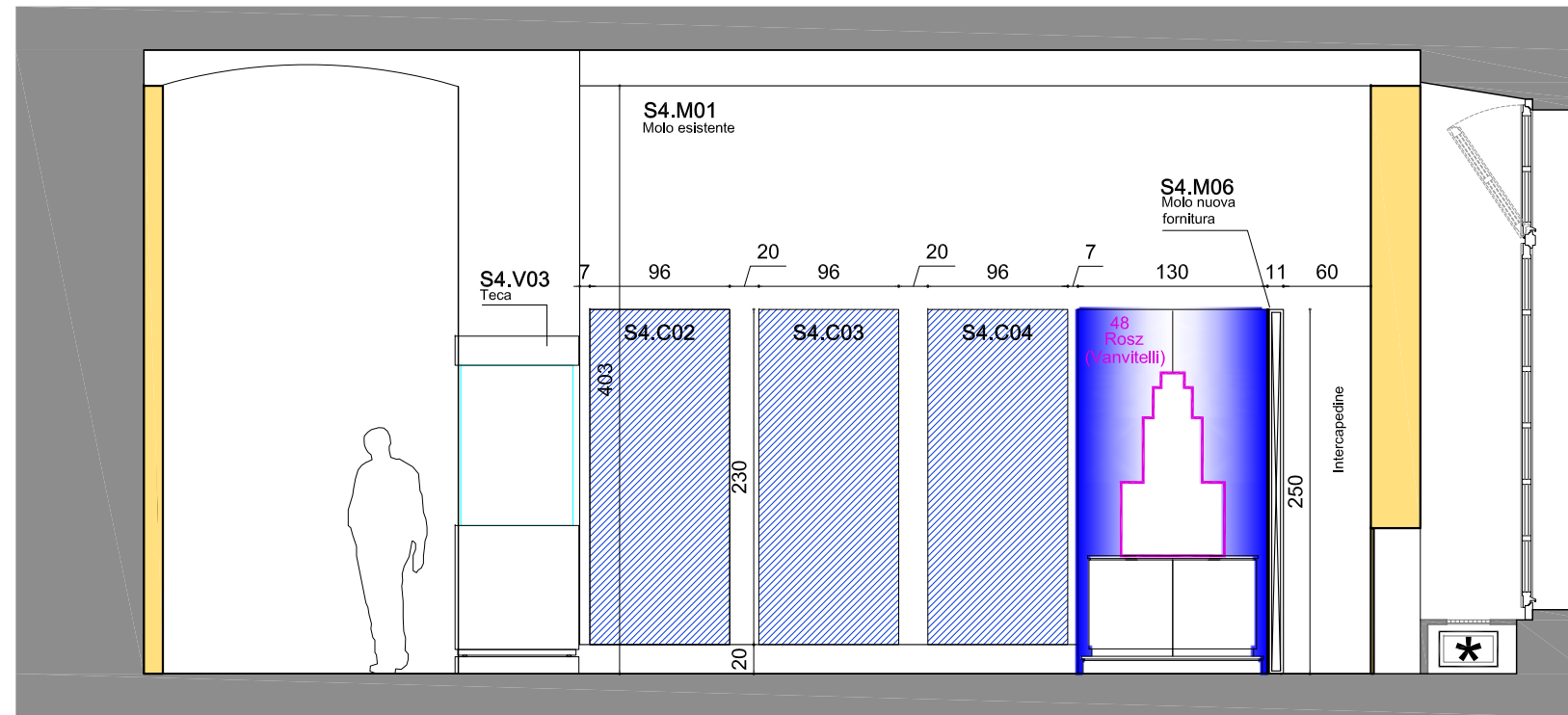

Parete 1

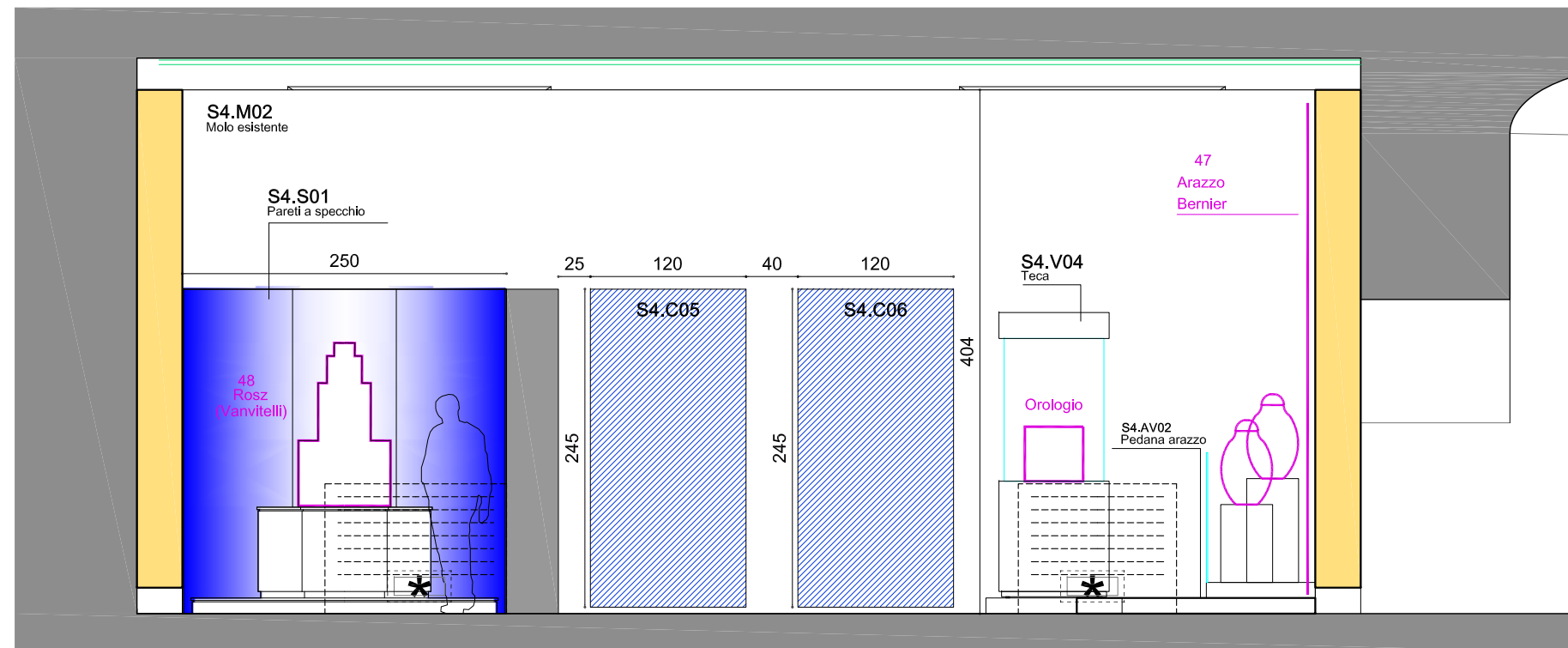

Parete 2

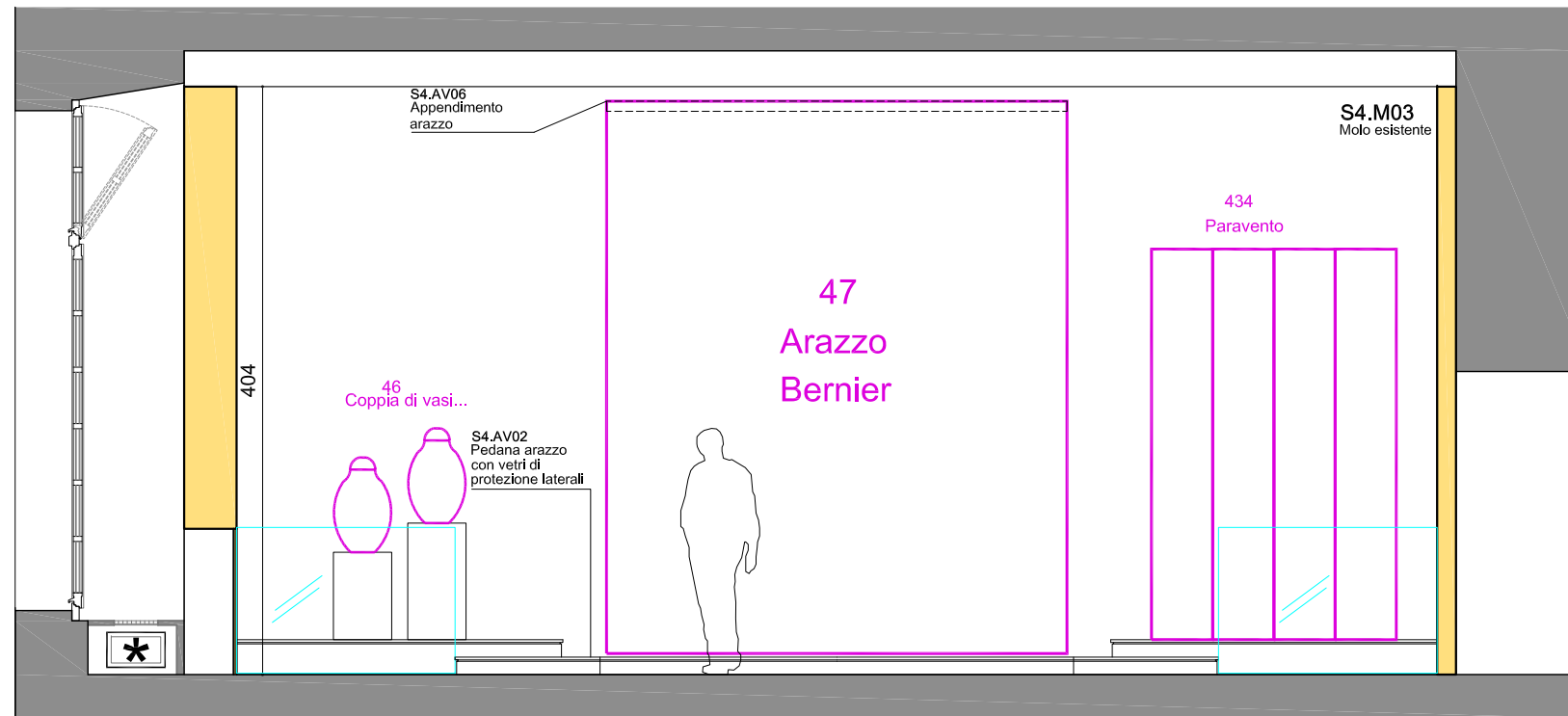

Parete 3

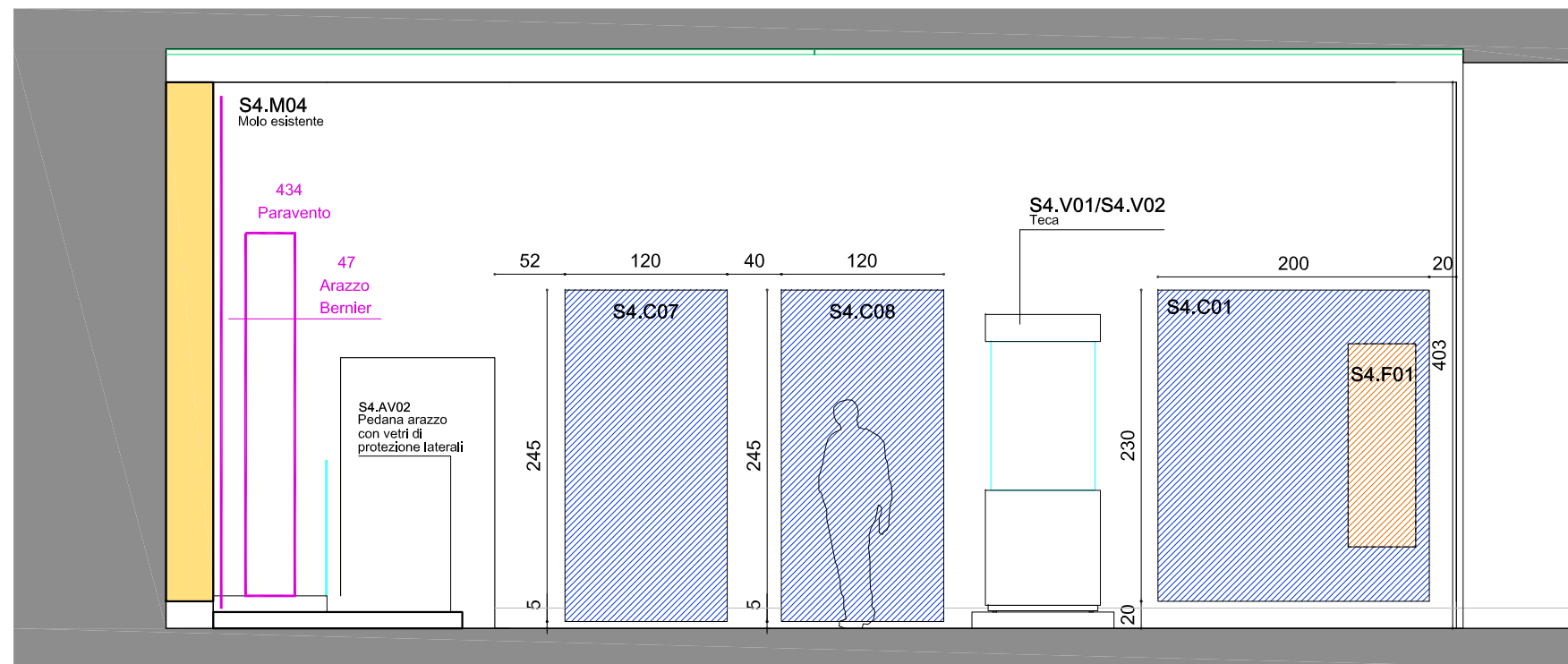

Parete 4

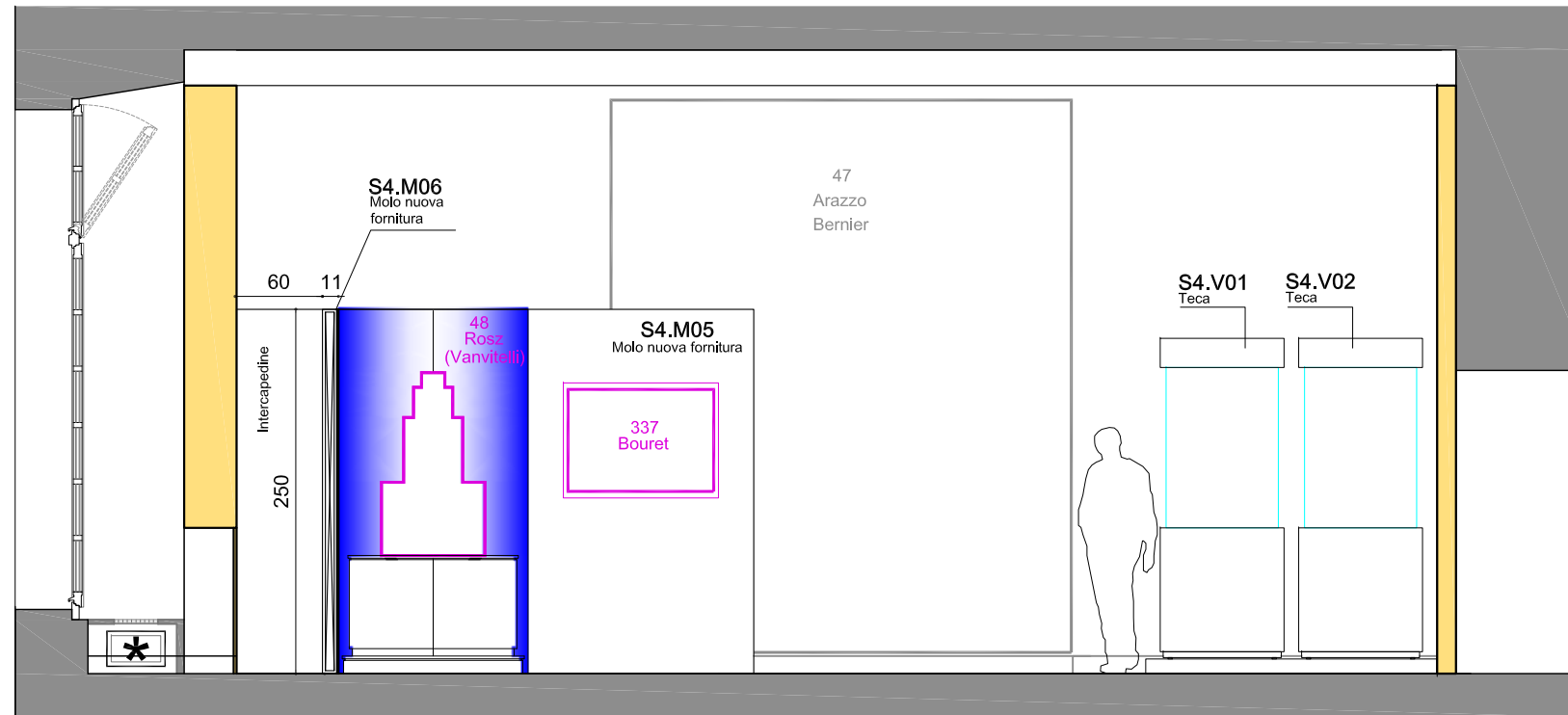

Parete 5

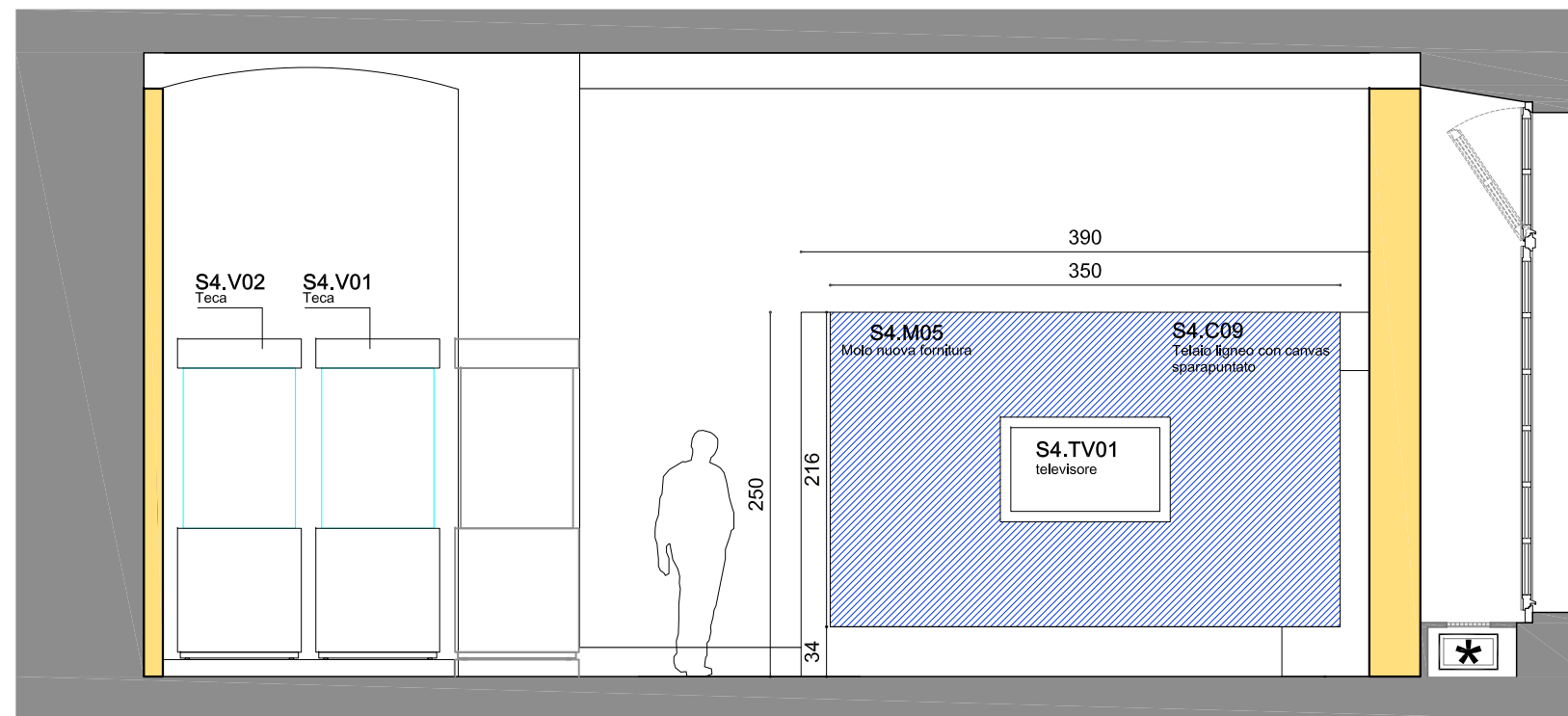

Parete 6

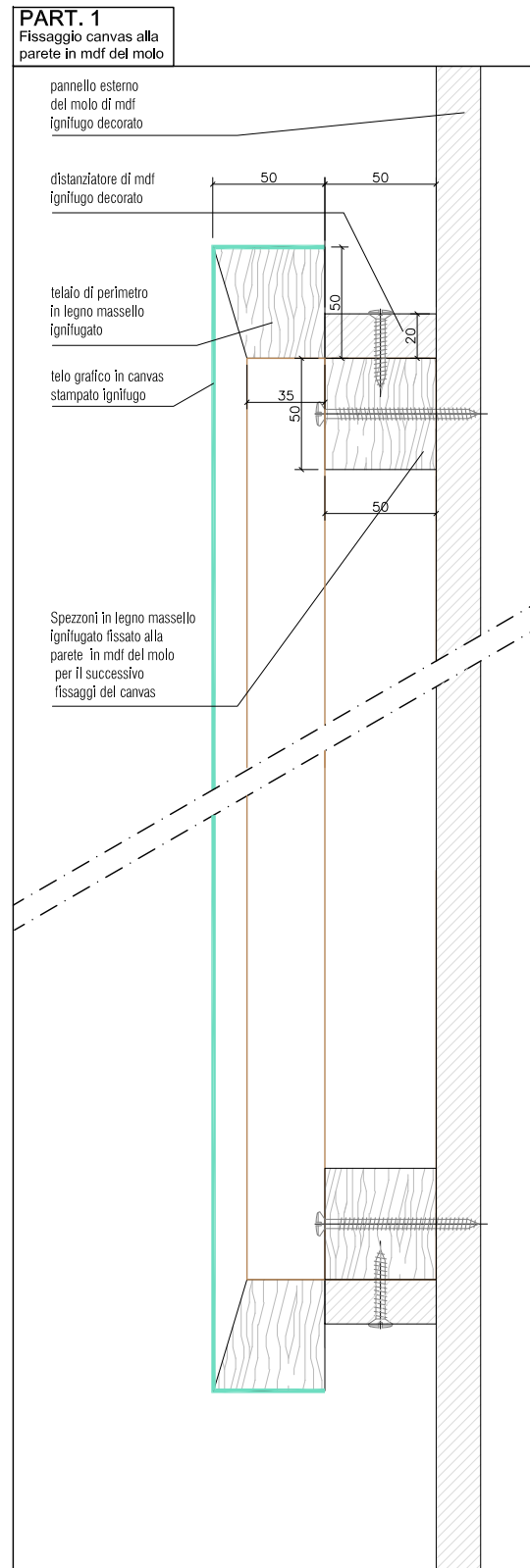
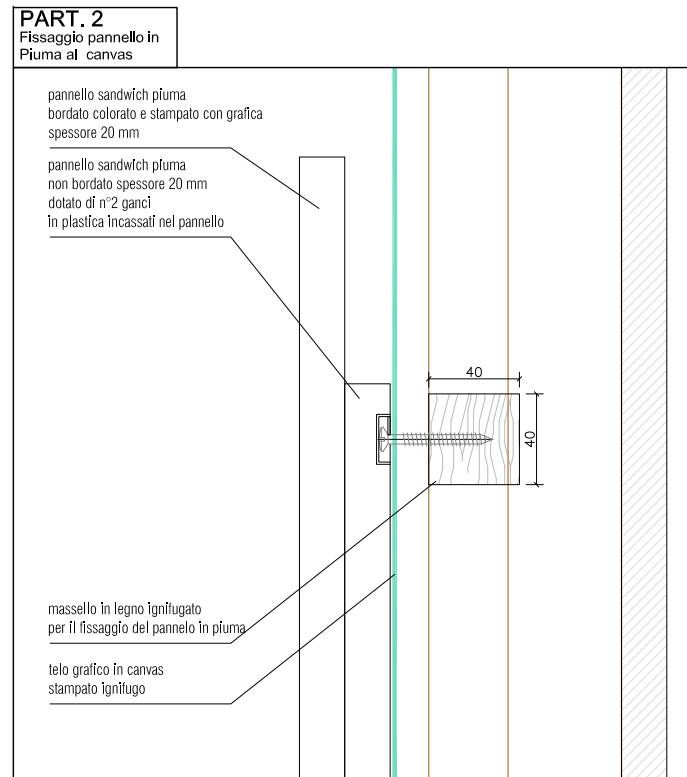

S4.C01
Telaio ligneo sparapuntato con telo grafico realizzato in masselli di legno ignifugato

S4.F01
Doppio pannello in piuma spessore 20 mm

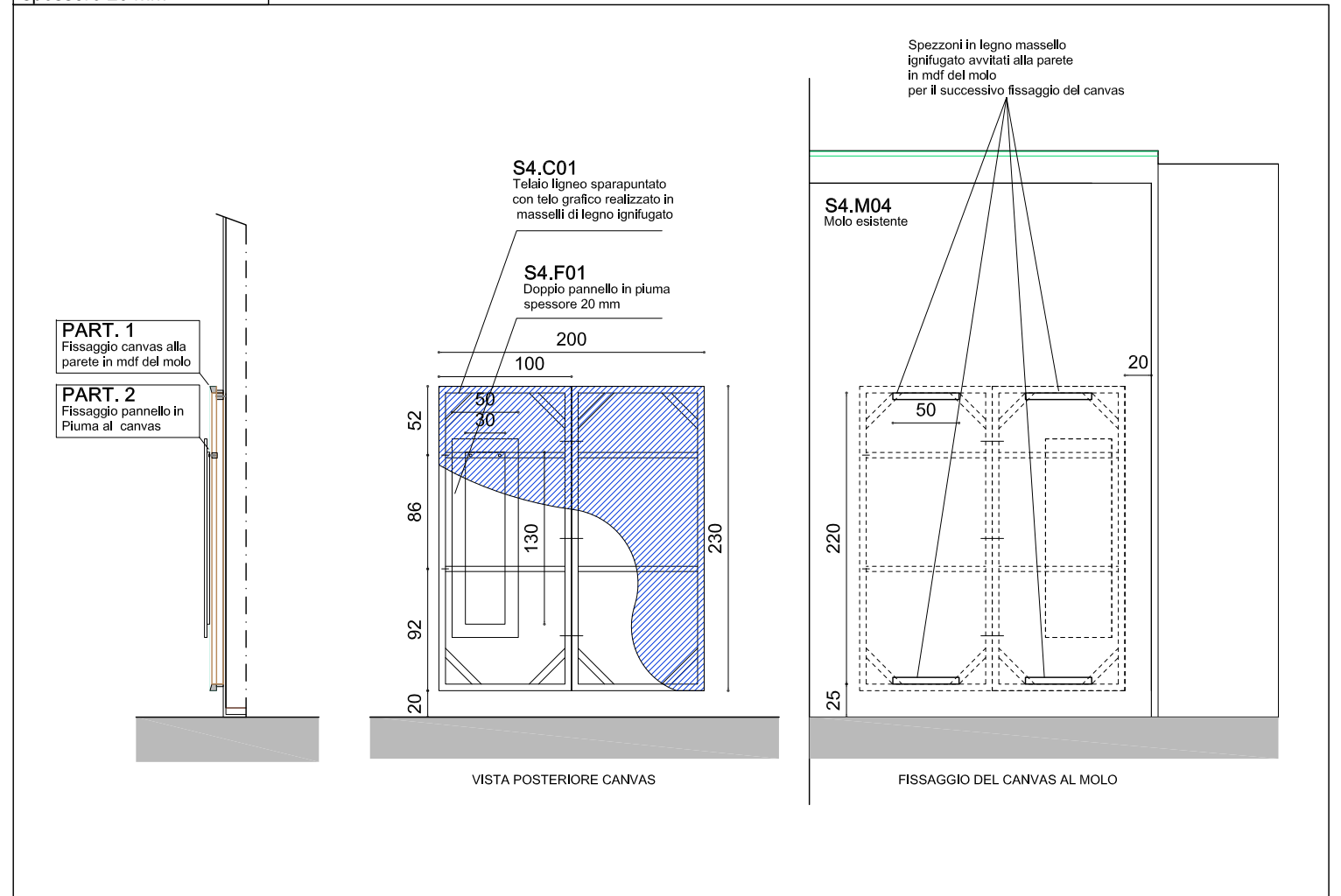

PART. 1
Fissaggio canvas alla parete in mdf del molo

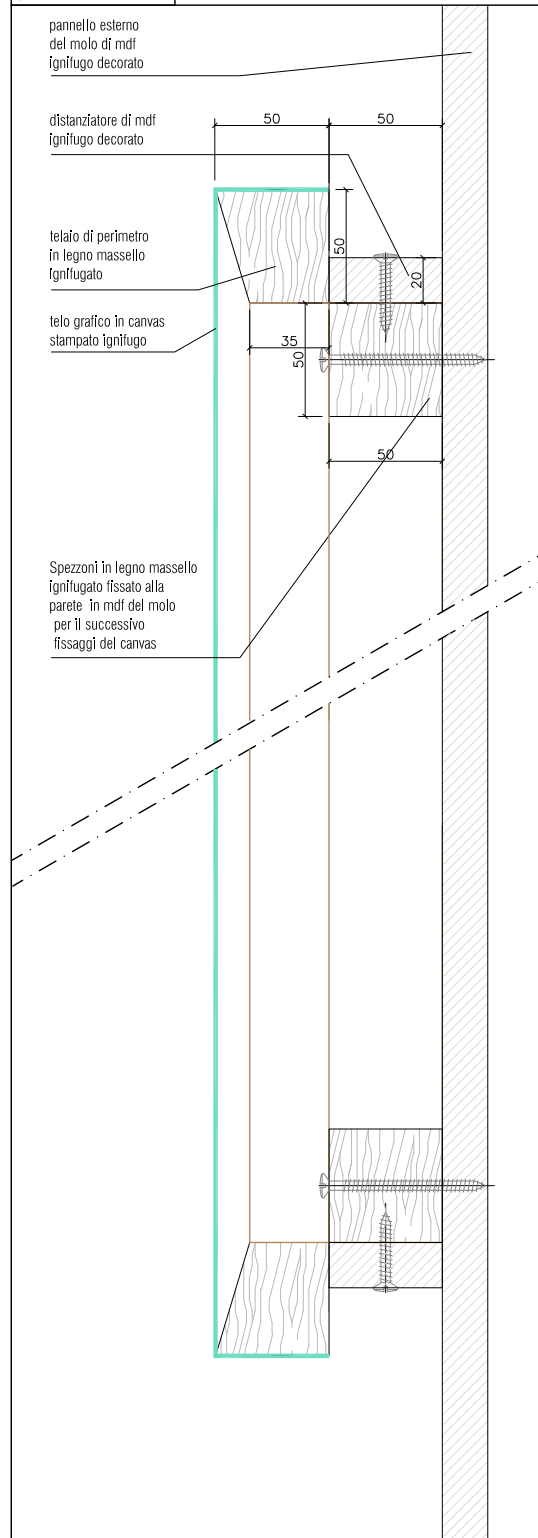

S4.C02/C03/C04
Telaio ligneo sparapuntato con telo grafico realizzato in masselli di legno ignifugato

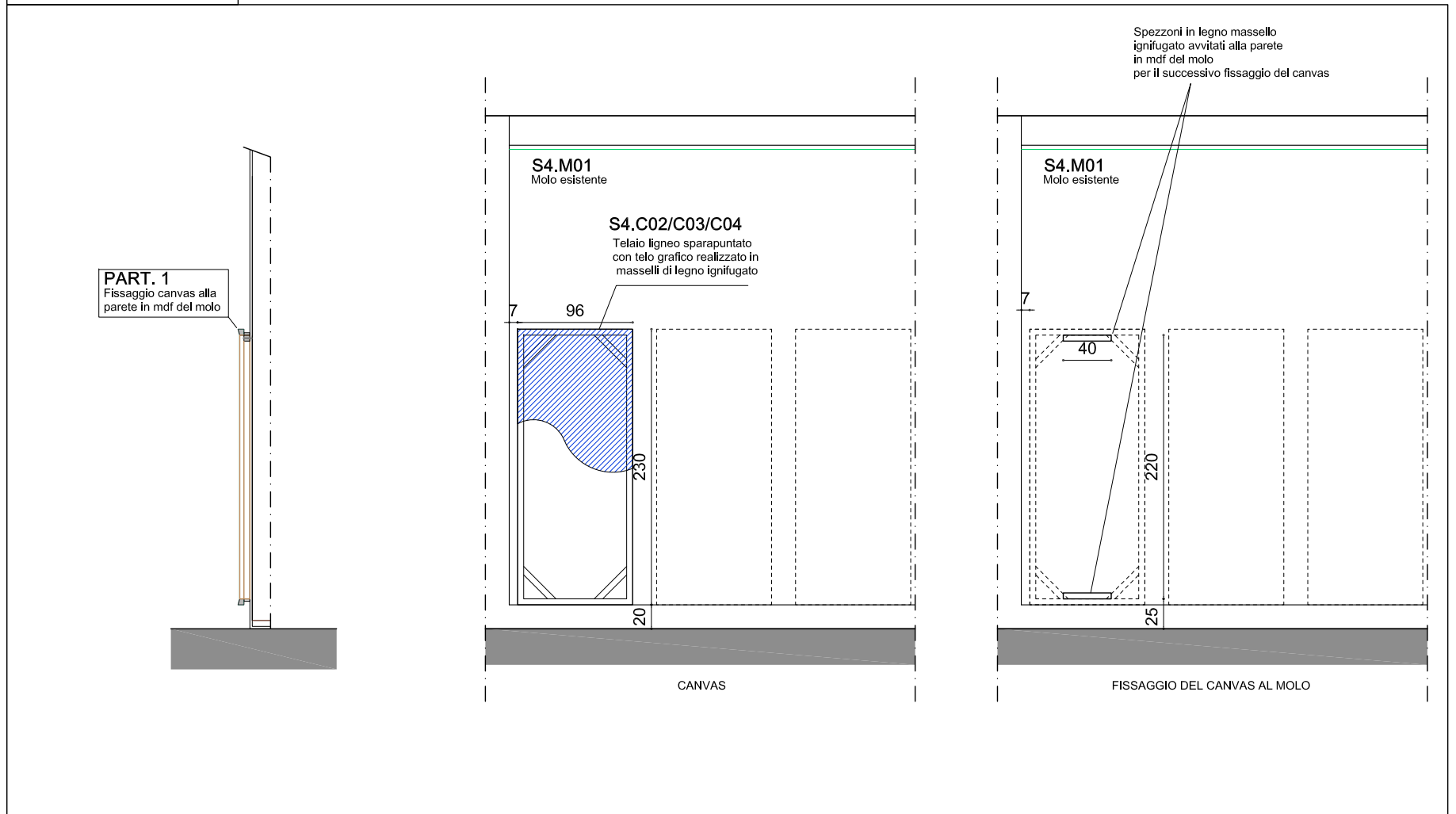

PART. 1
Fissaggio canvas alla parete in mdf del molo

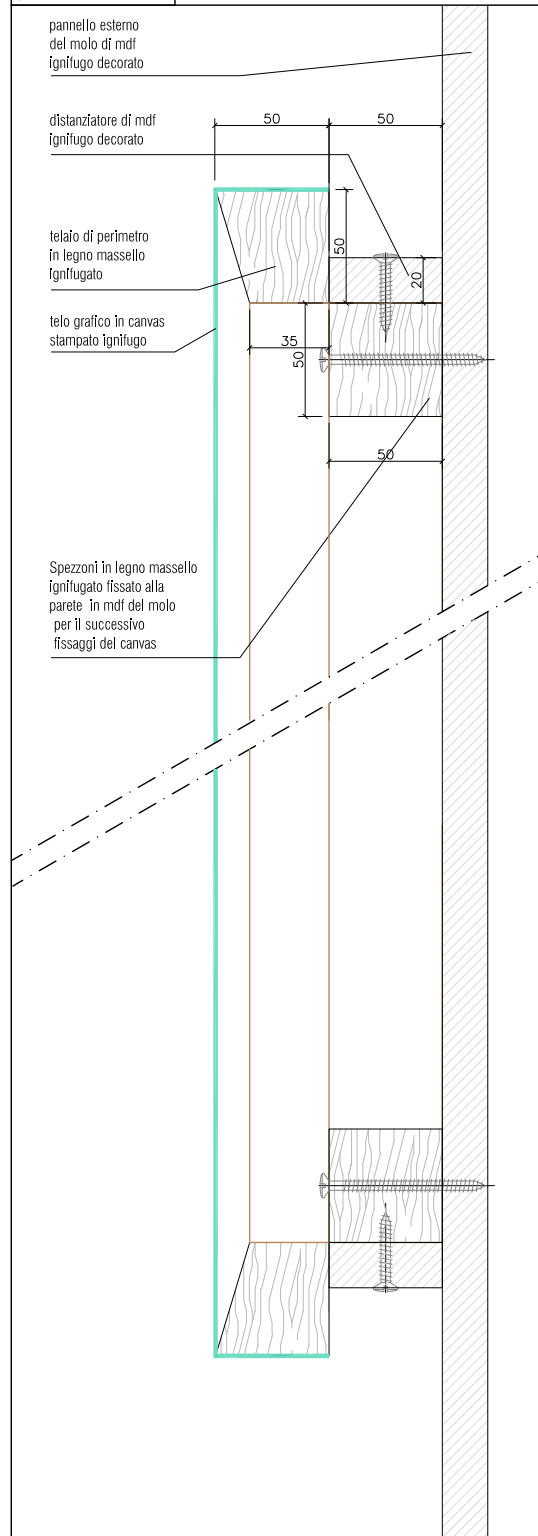

S4.C05/C06/C07/C08
Telaio ligneo sparapuntato con telo grafico realizzato in masselli di legno ignifugato

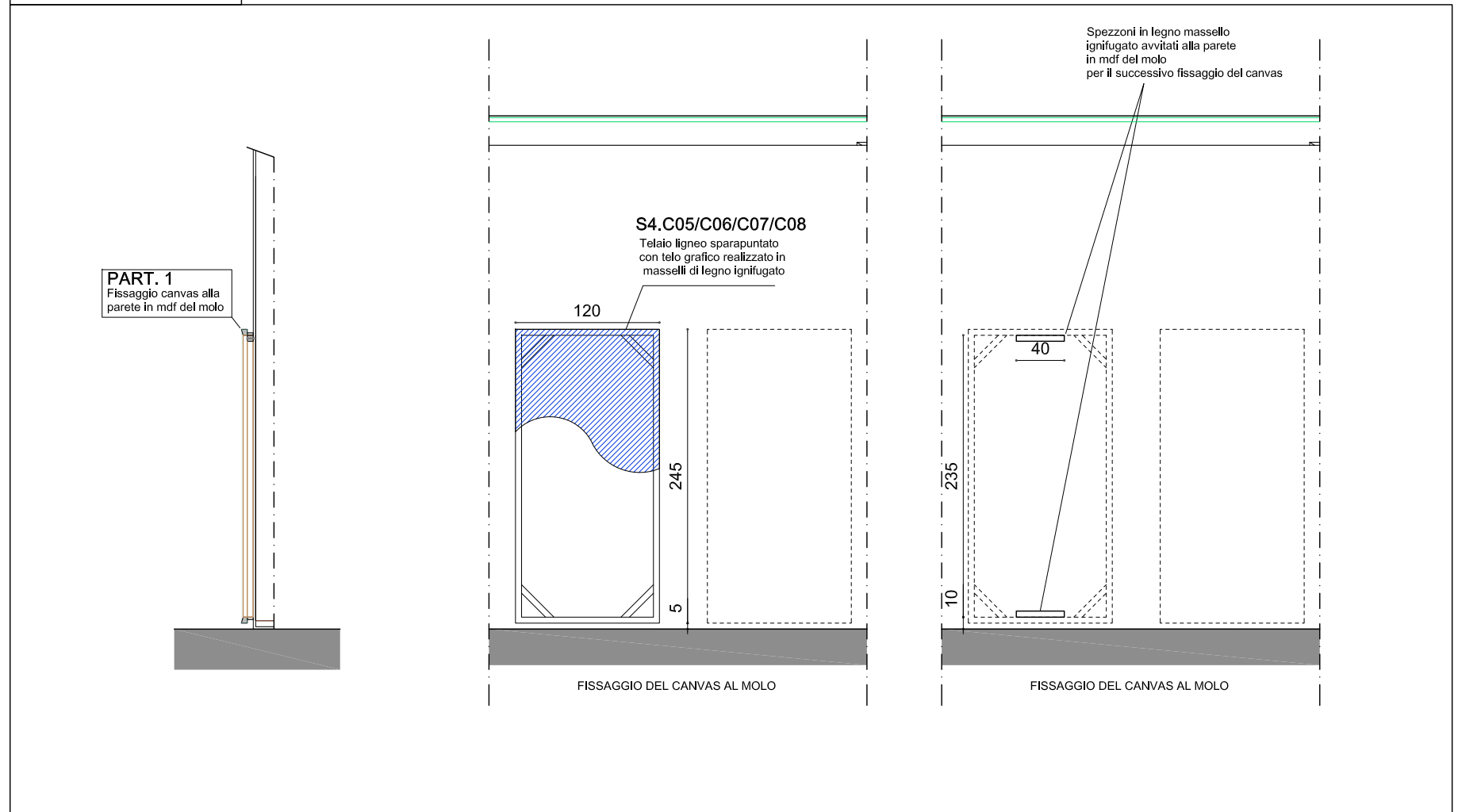

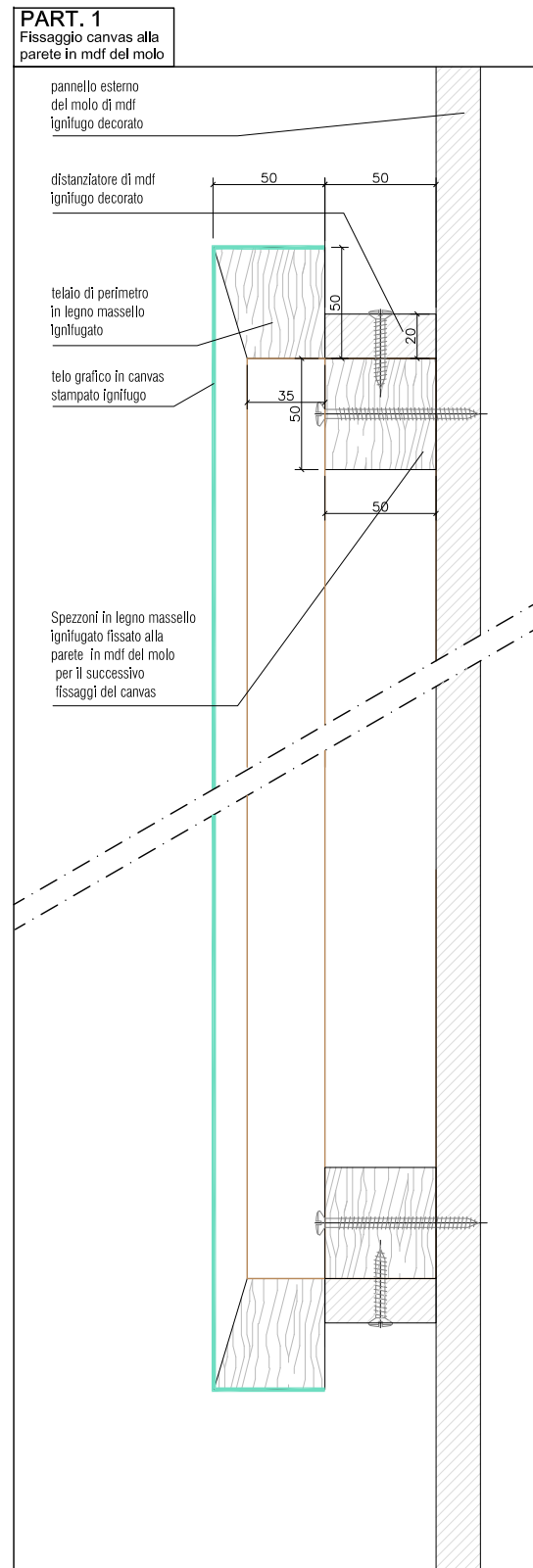
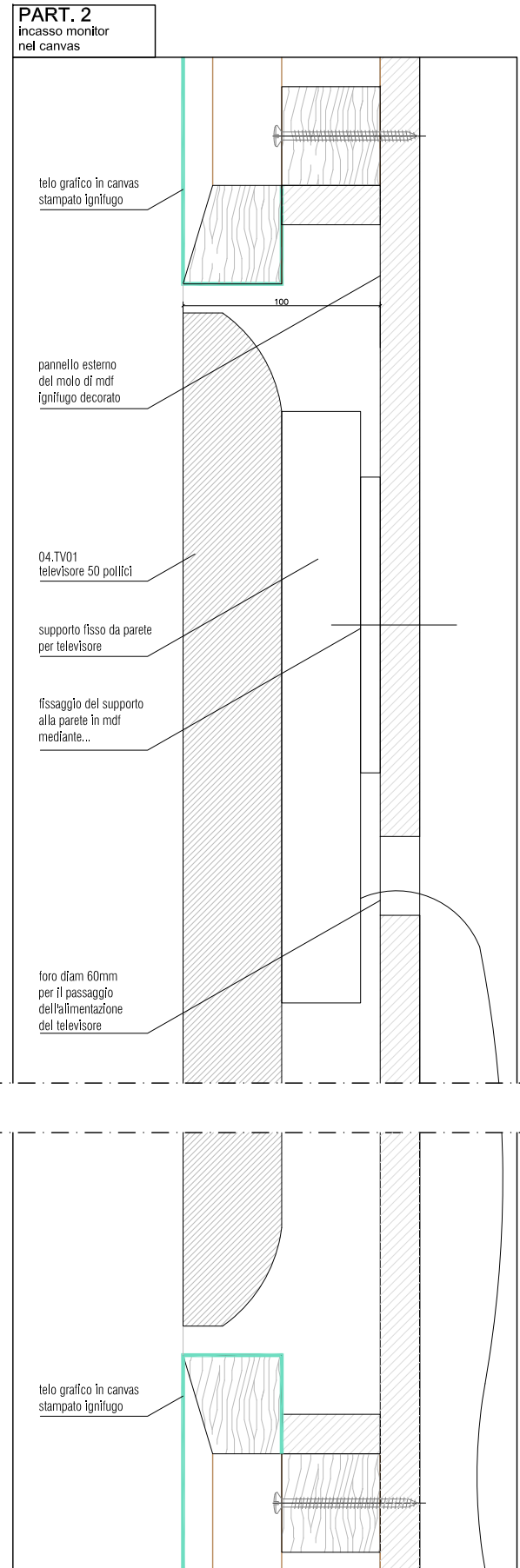

S4.C09
Telaio ligneo sparapuntato con telo grafico realizzato in masselli di legno ignifugato

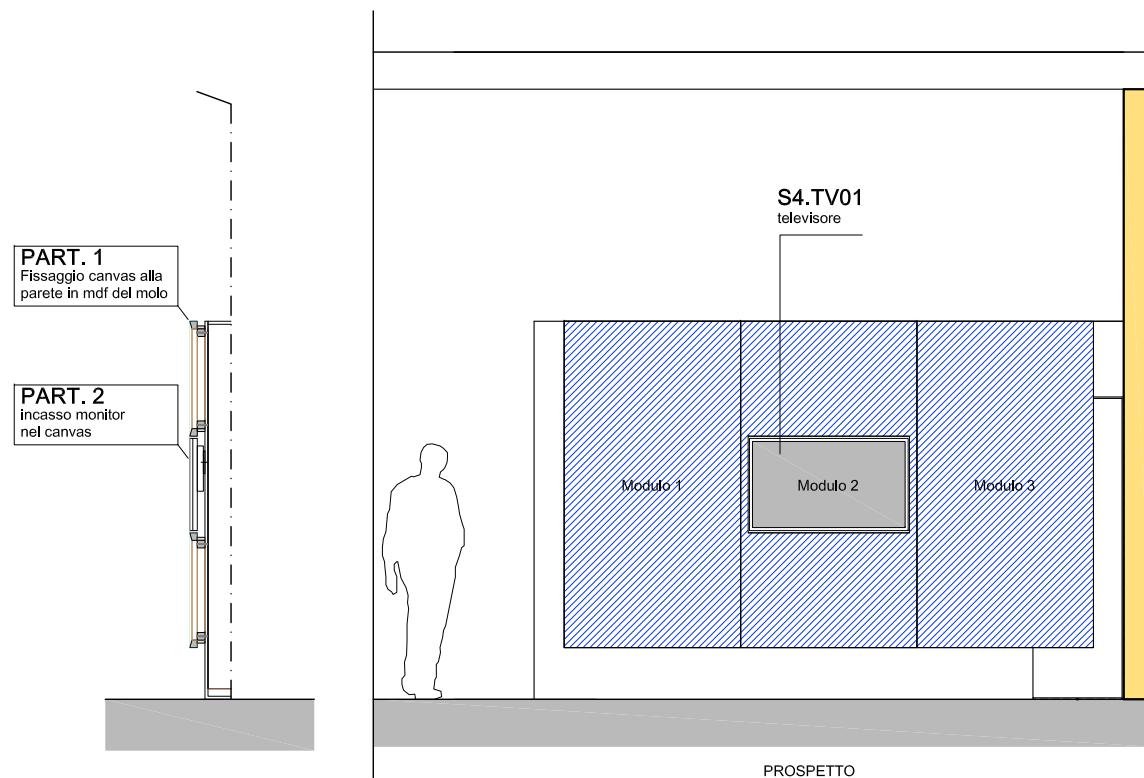
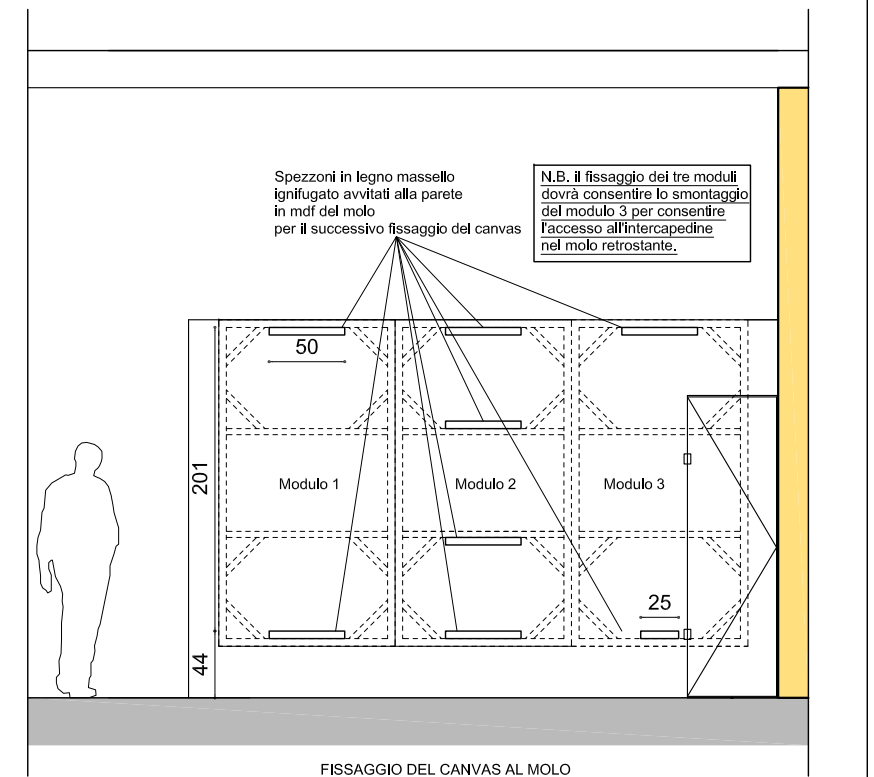
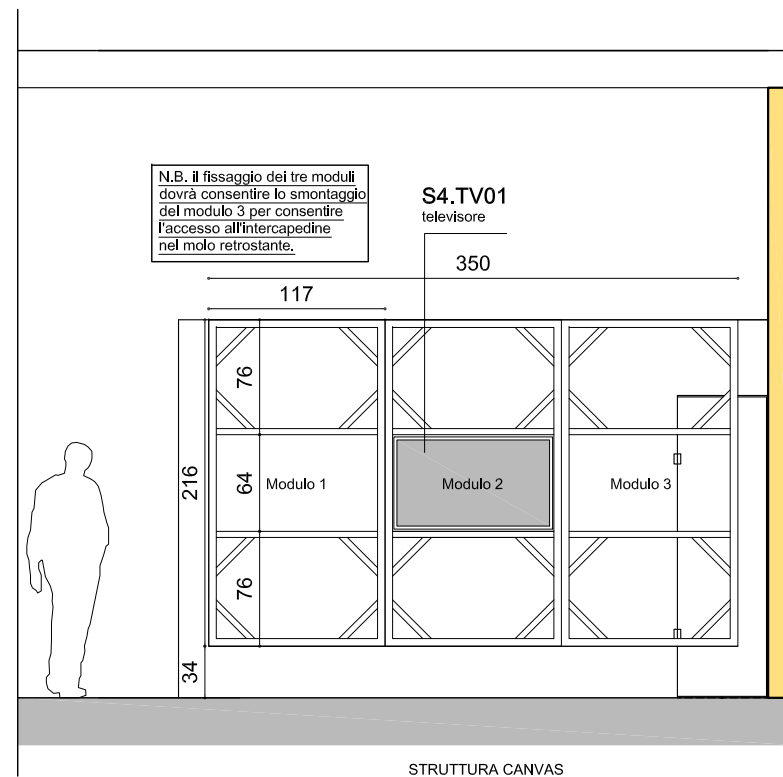

PART. 1
finitura pedana

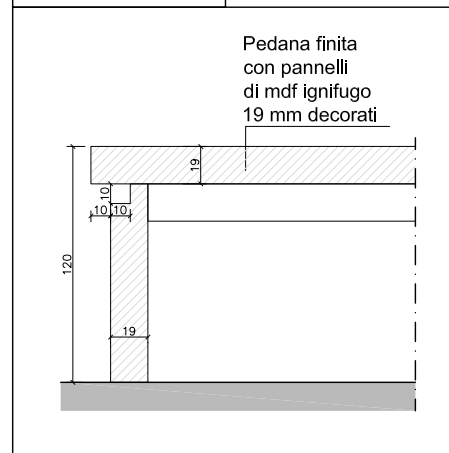

Supporto vasi

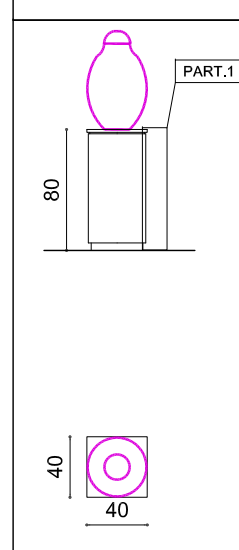

PART. 3
modalità di fissaggio vetri al muro

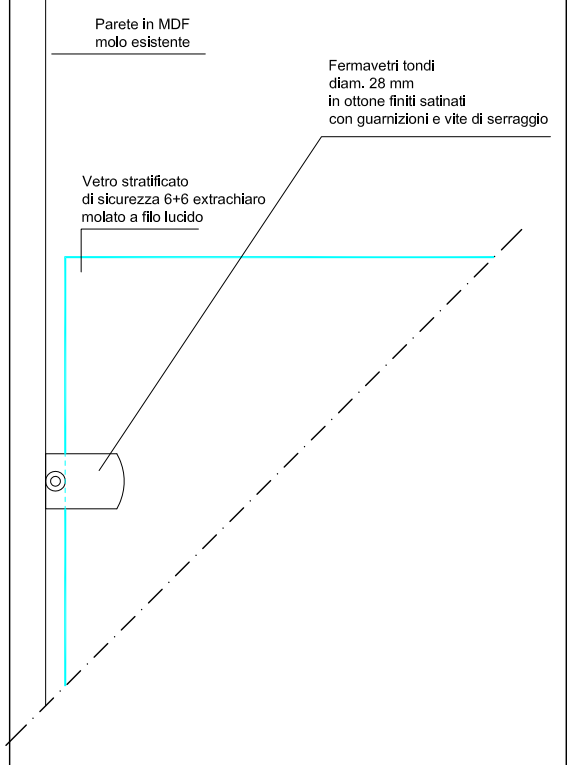

PART. 2
modalità di fissaggio vetri alla pedana

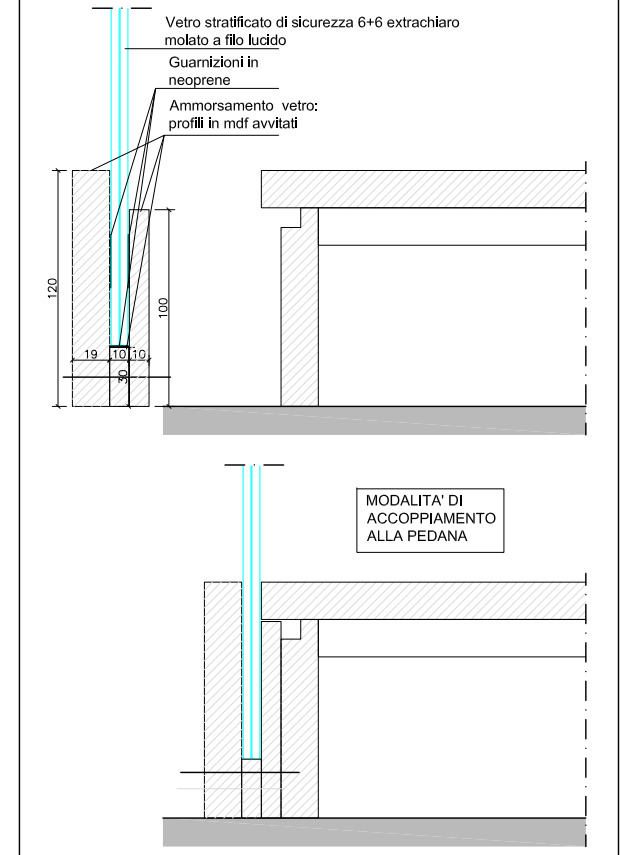

S4.AV02
Pedana arazzo
con vetri di protezione laterali

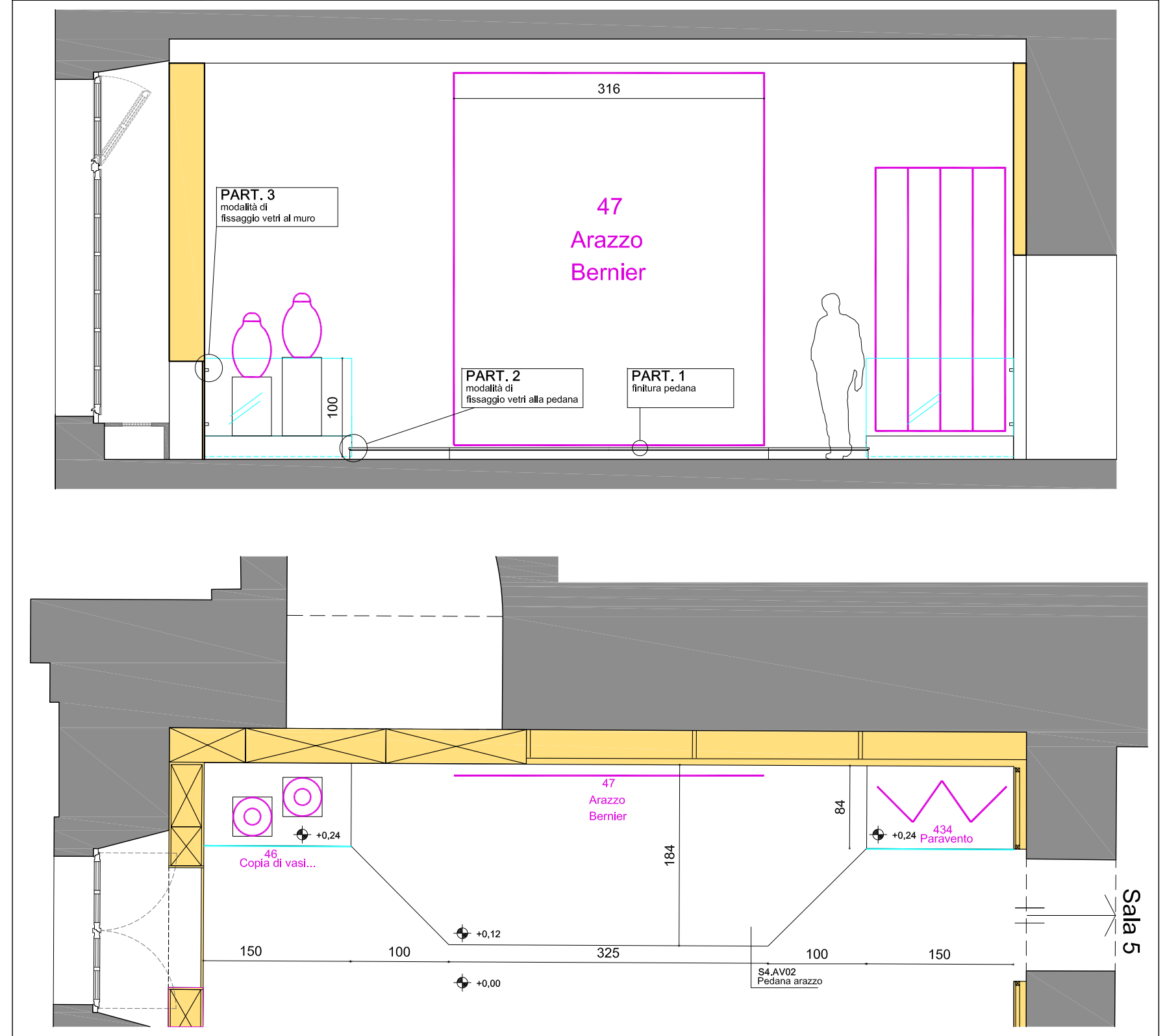

S4.AV06
Appendimento arazzo

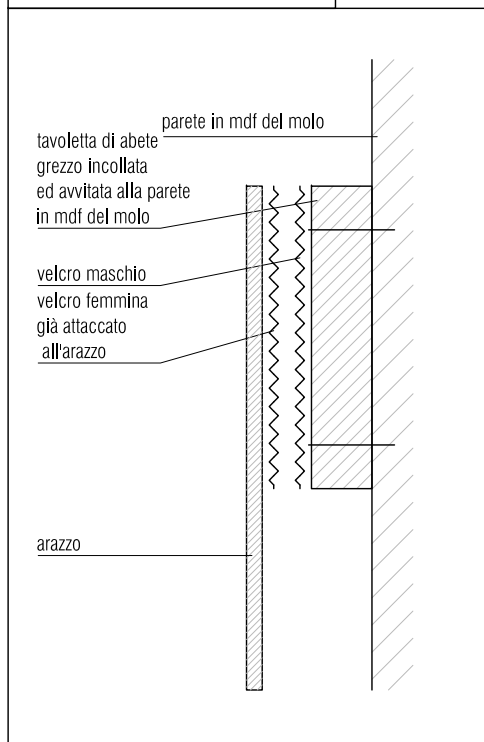

S4.S01
pareti a specchio

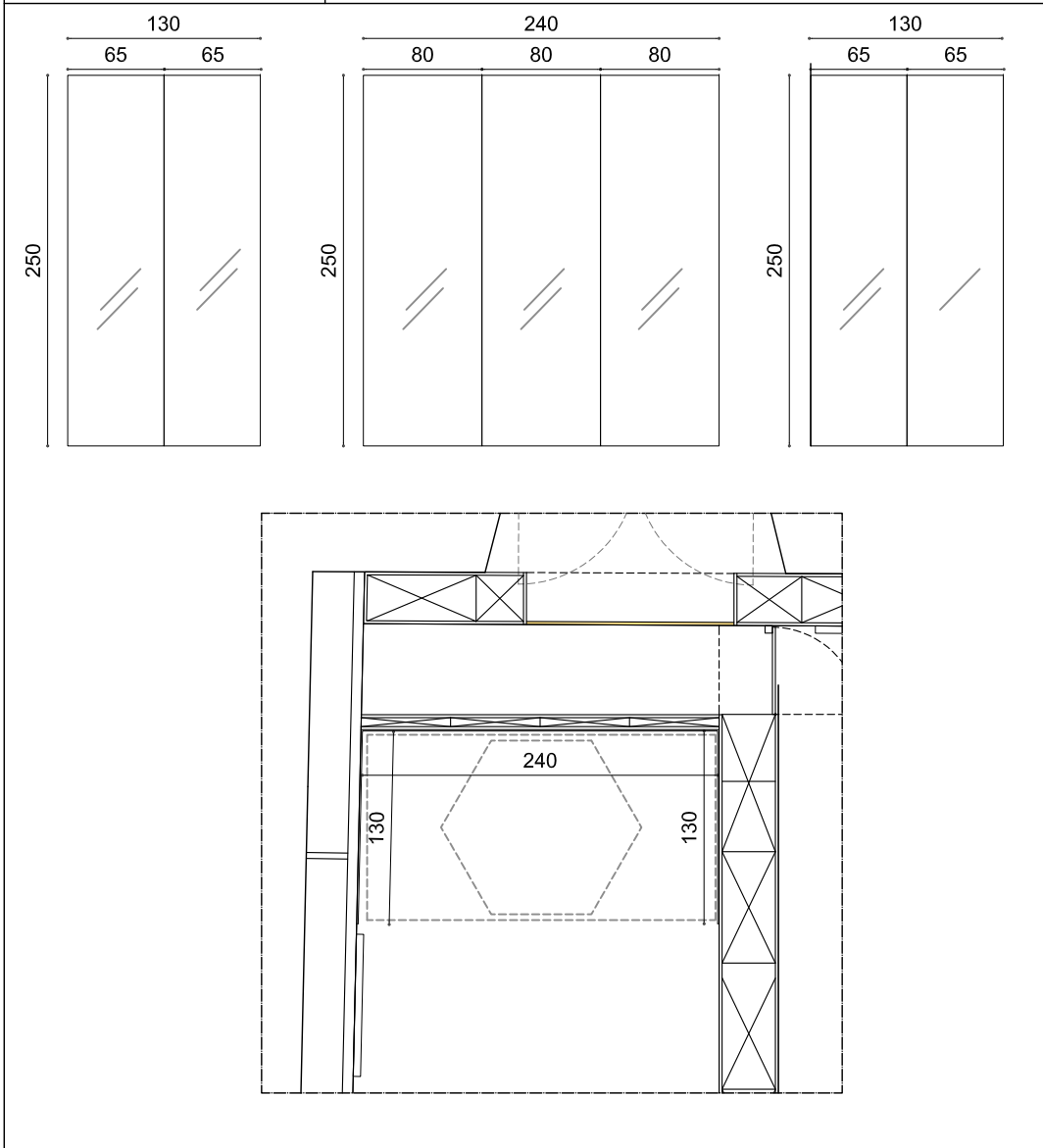

S4.AV7
Supporto opera:
modello ligneo

S4.AV3
pedana modello ligneo

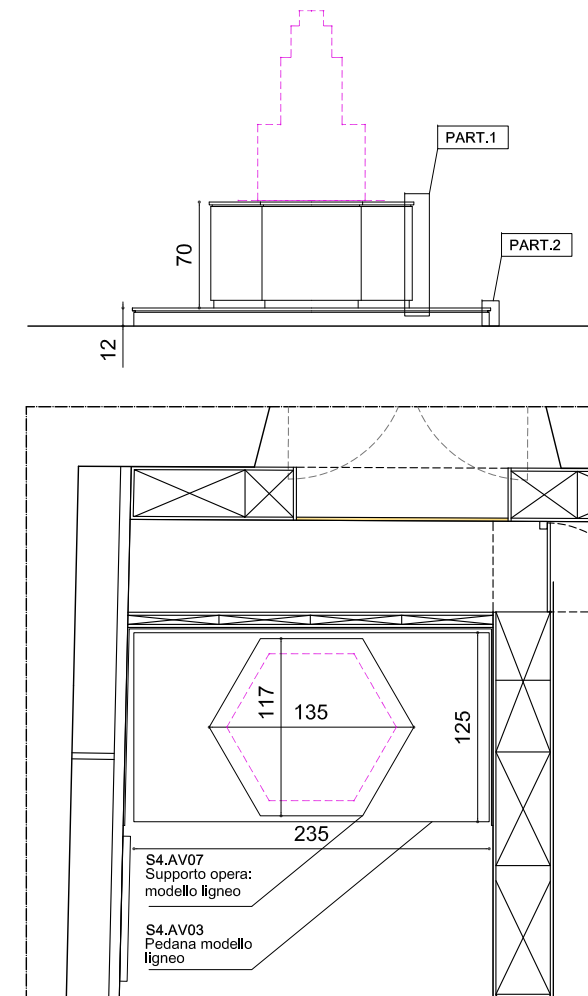

PART. 1
finitura supporti
modello ligneo

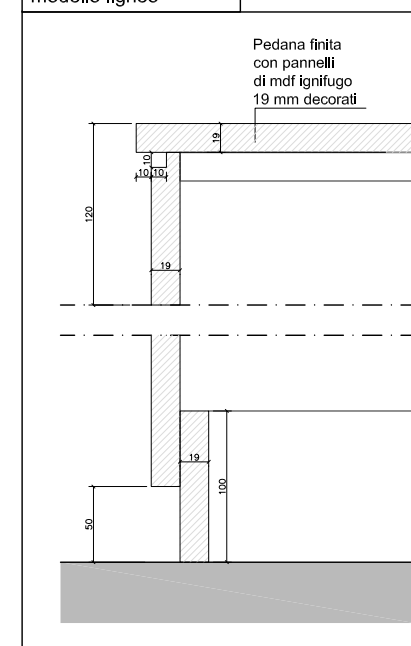

PART. 2
finitura pedana

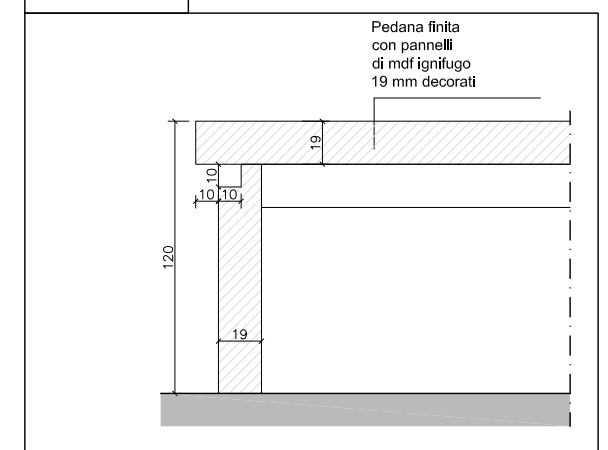

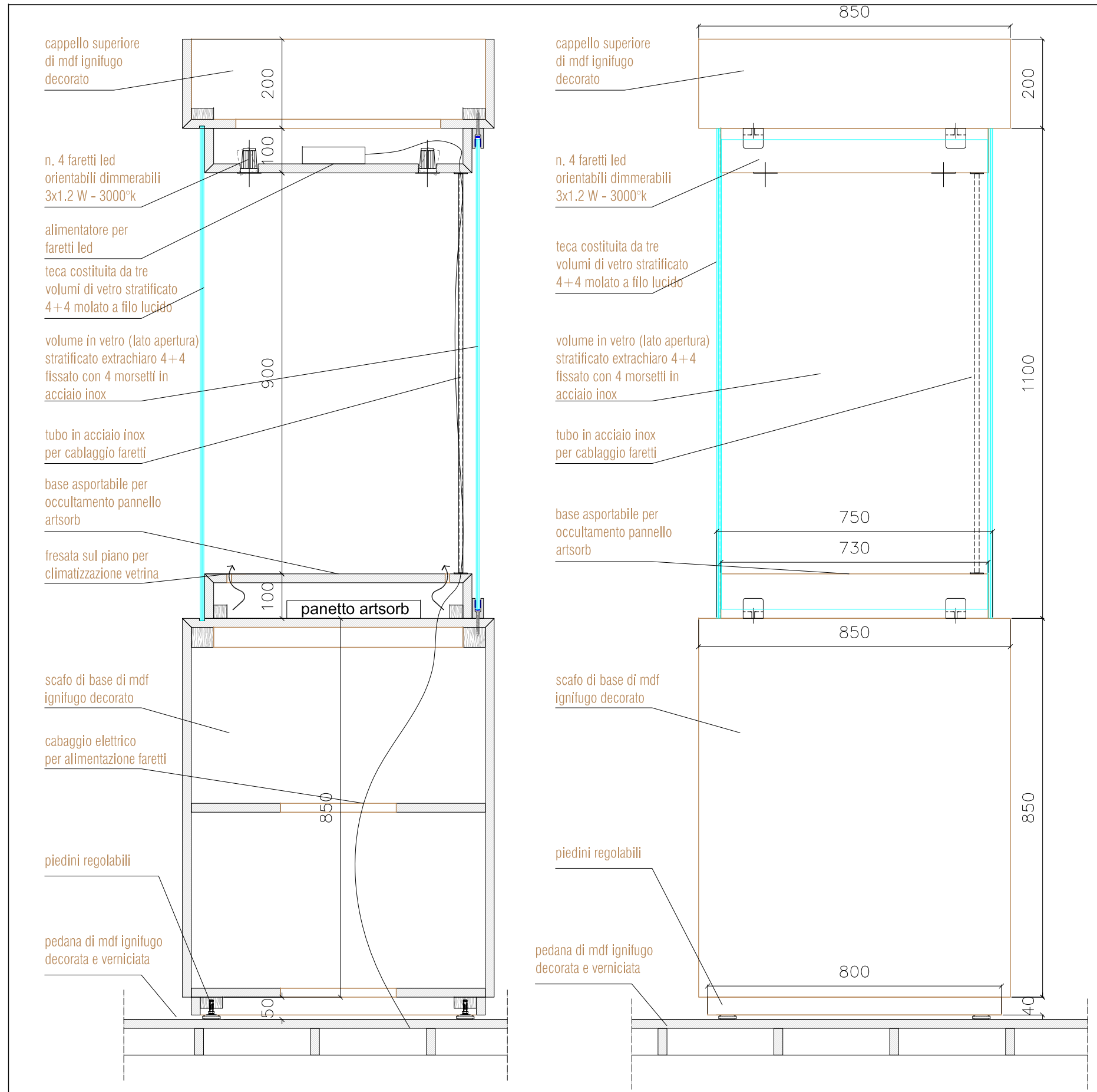

S4.V01/V02/V03/V4
Teca

S4.AV01
Pedana teche

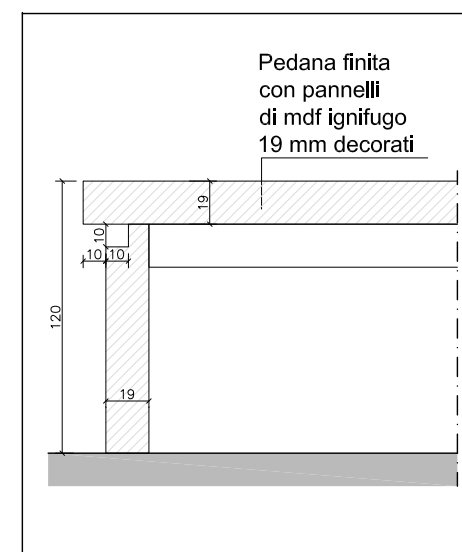
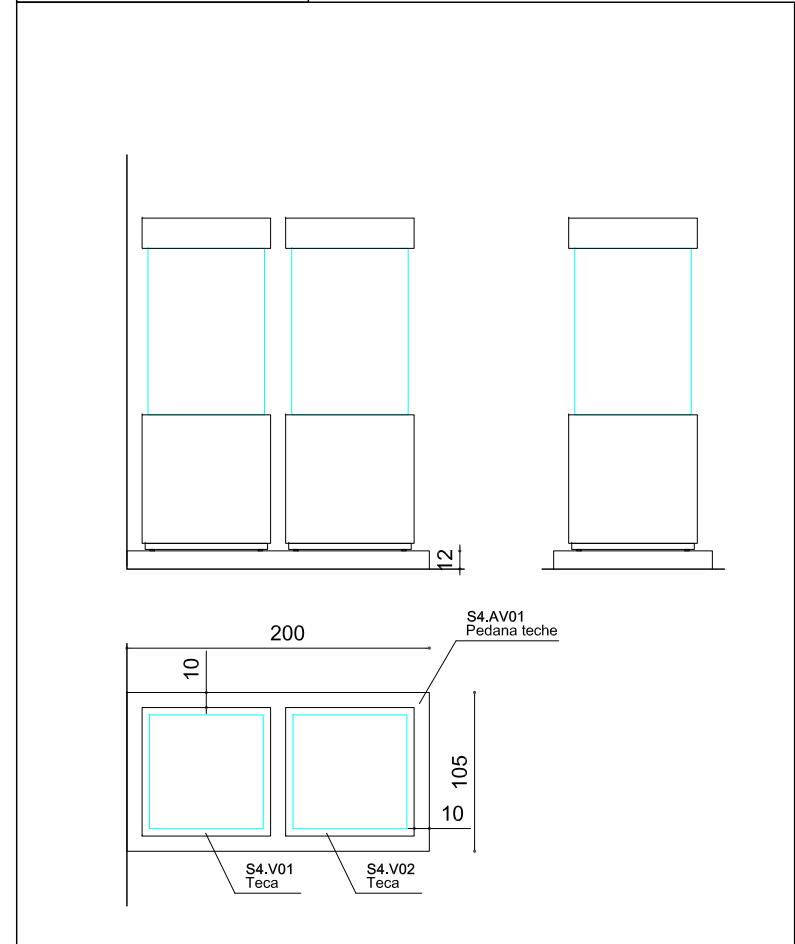

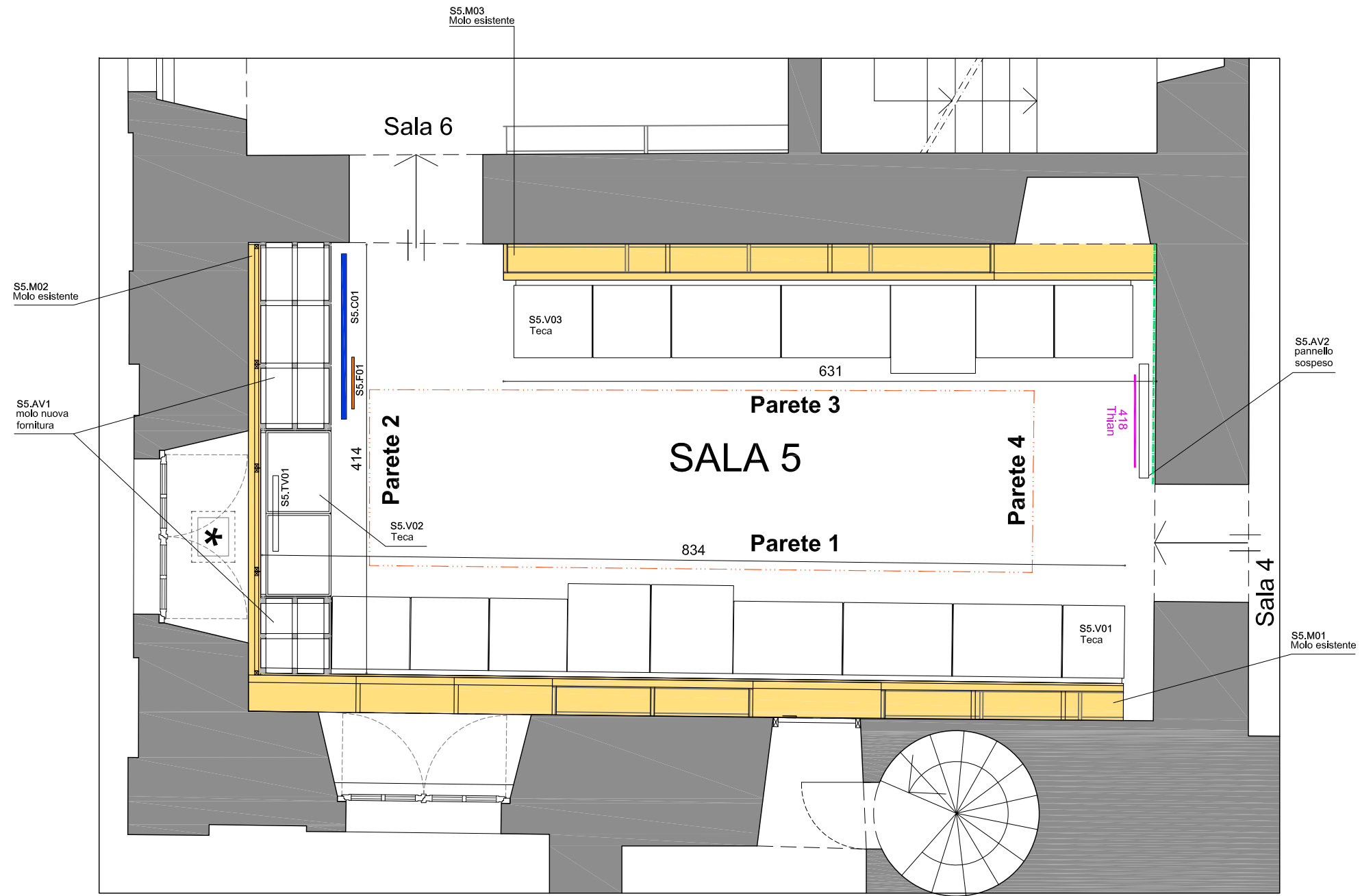

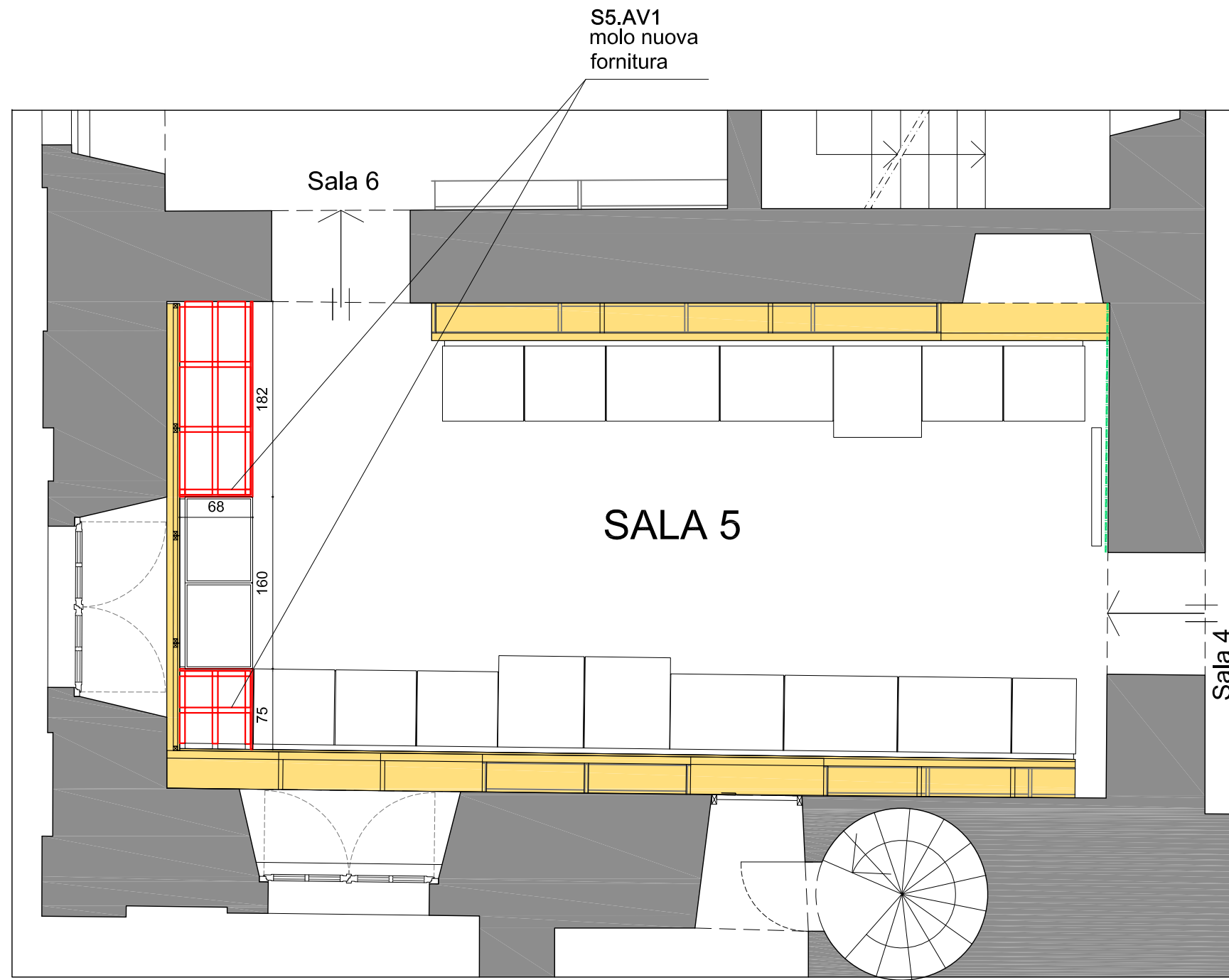

 COSTRUZIONE

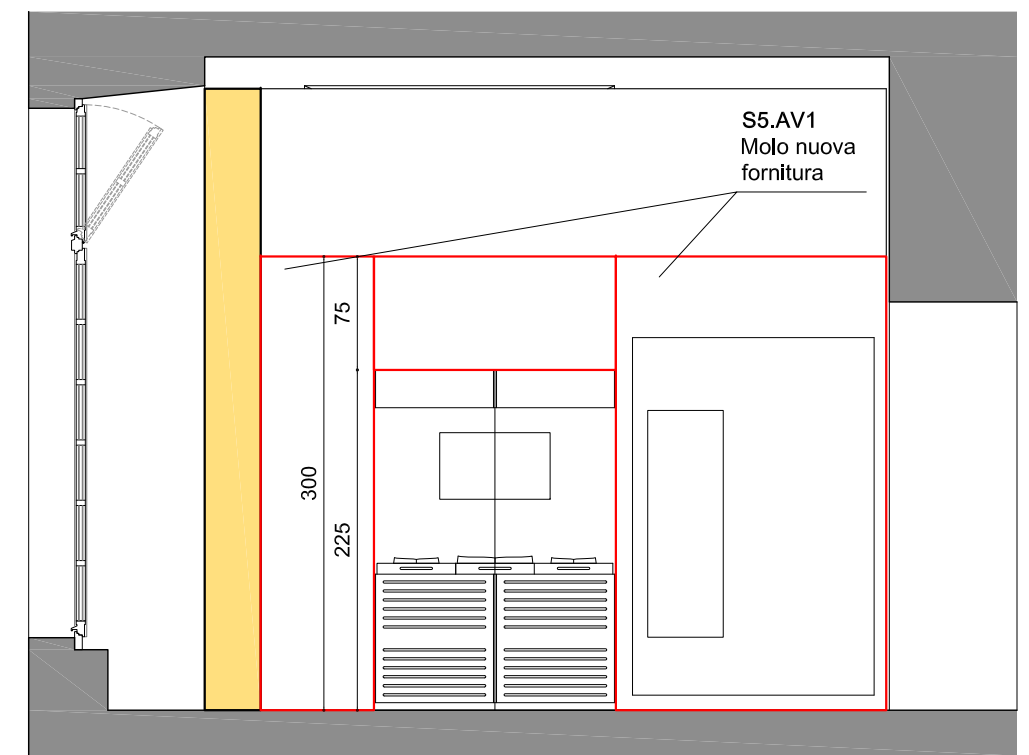

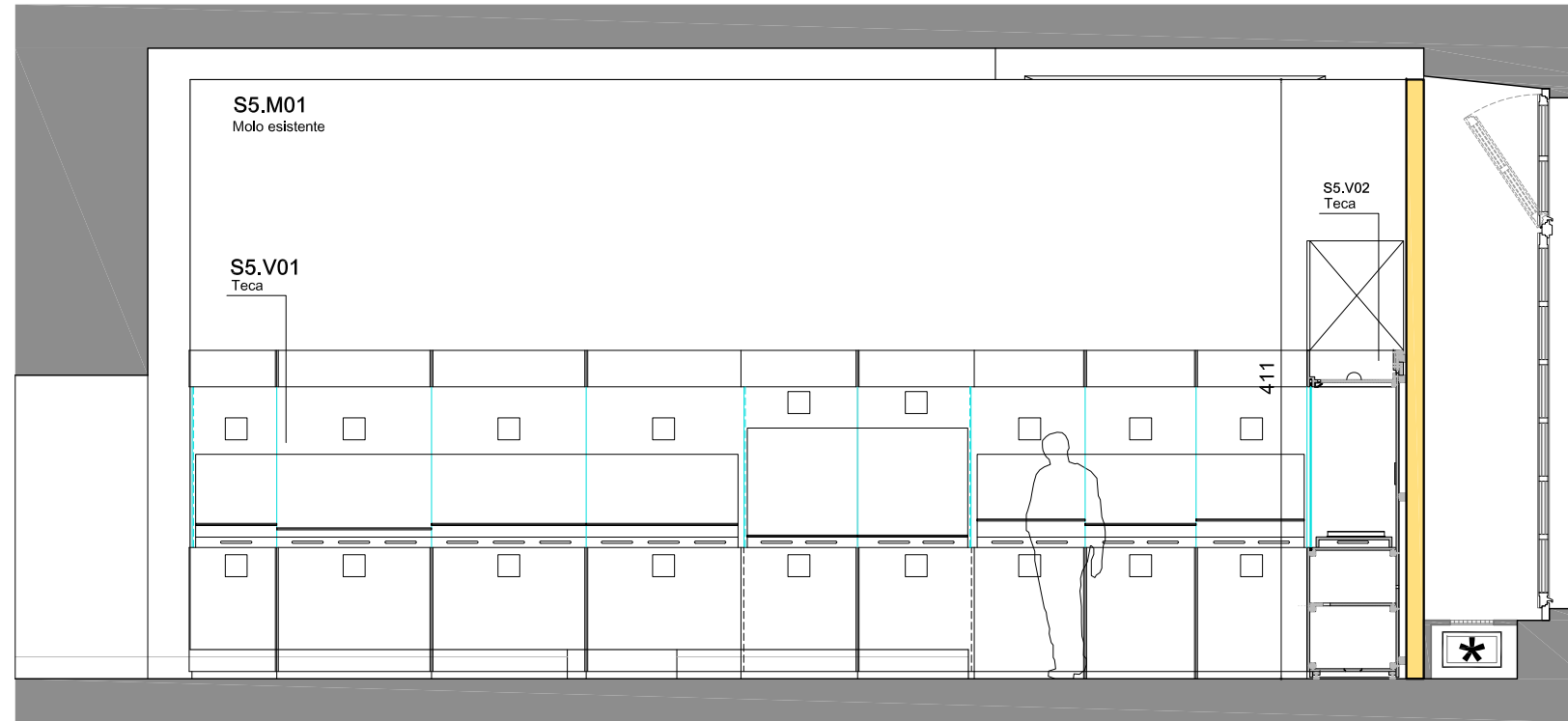

Parete 1

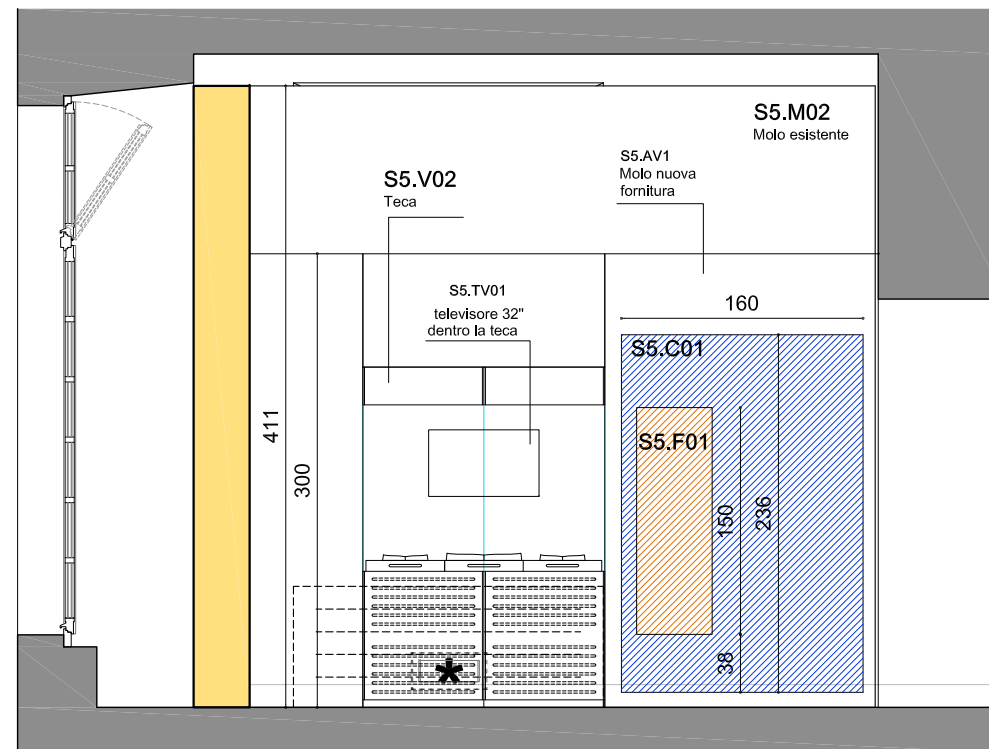

Parete 2

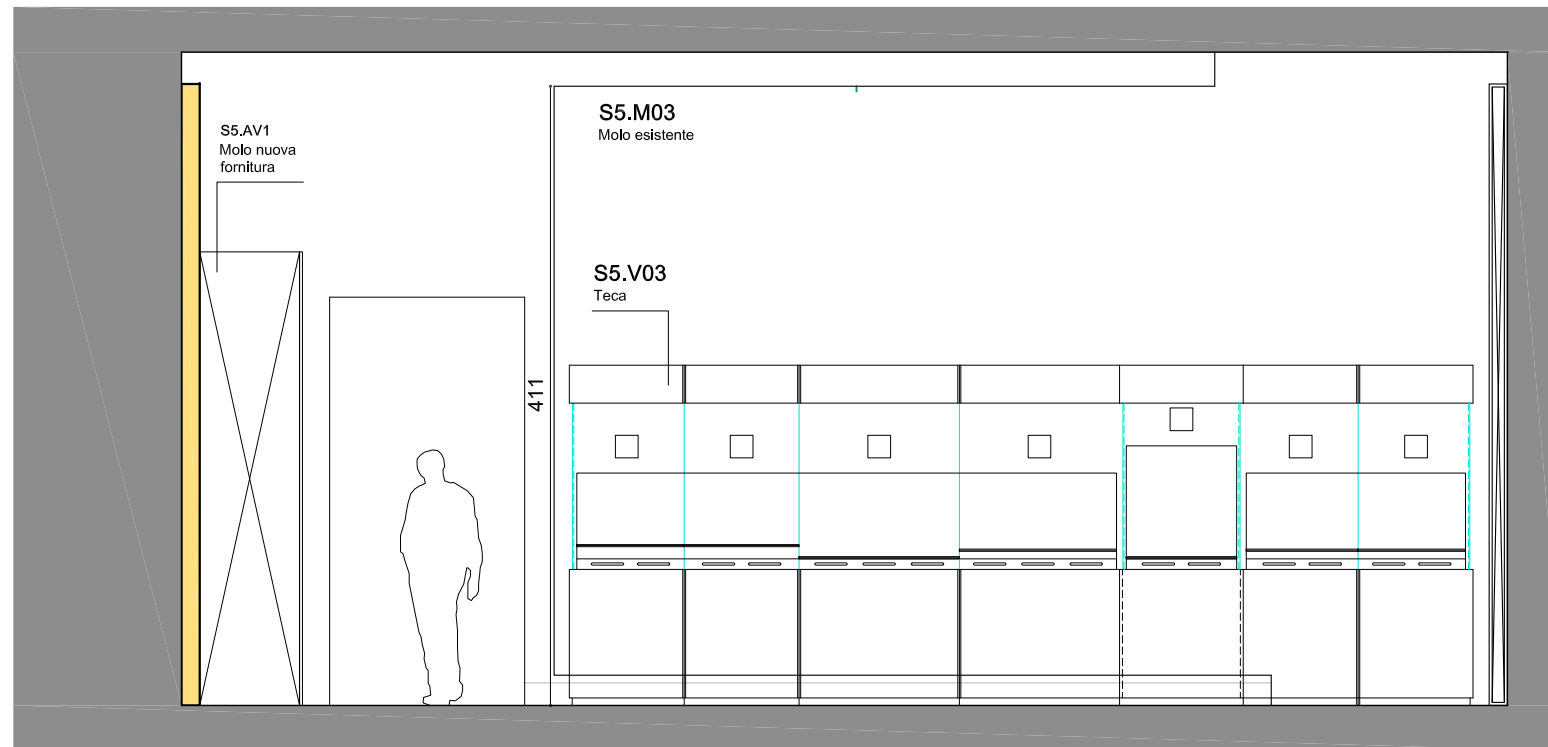

Parete 3

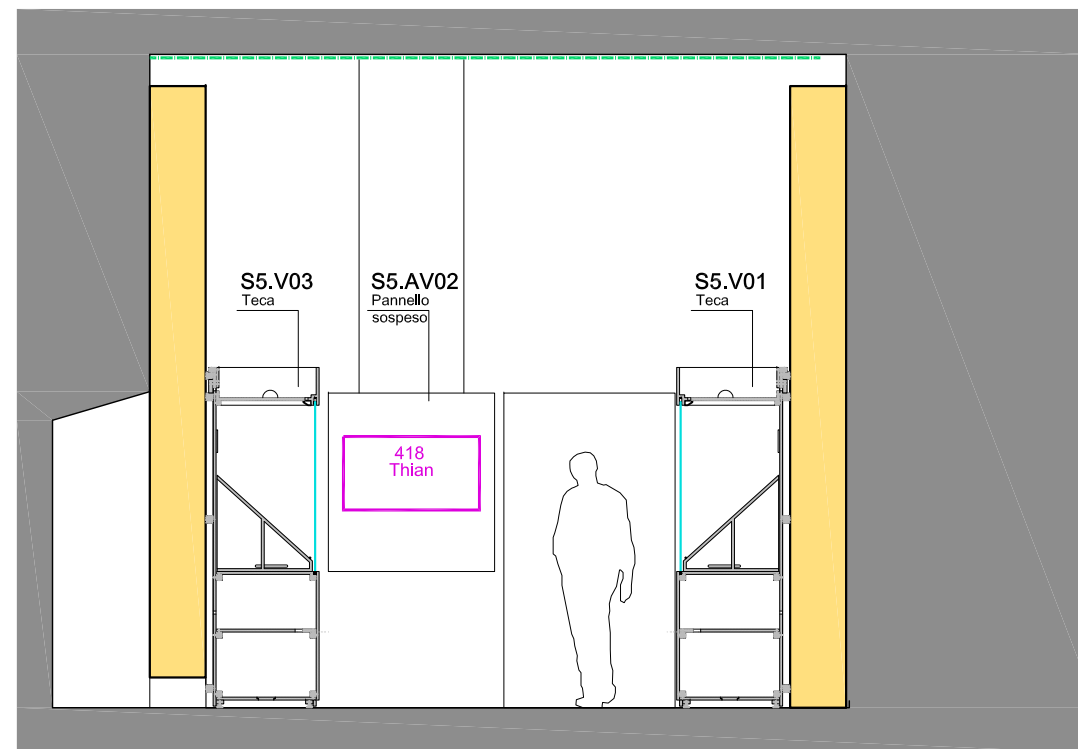

Parete 4

PROSPETTO FRONTALE

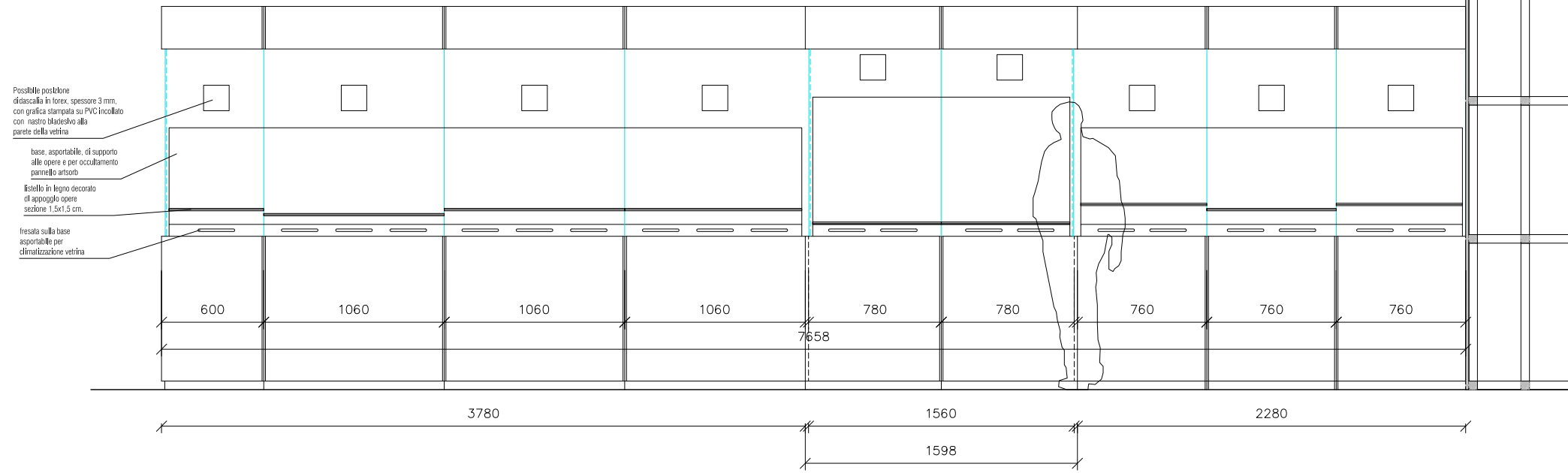

PIANTA B

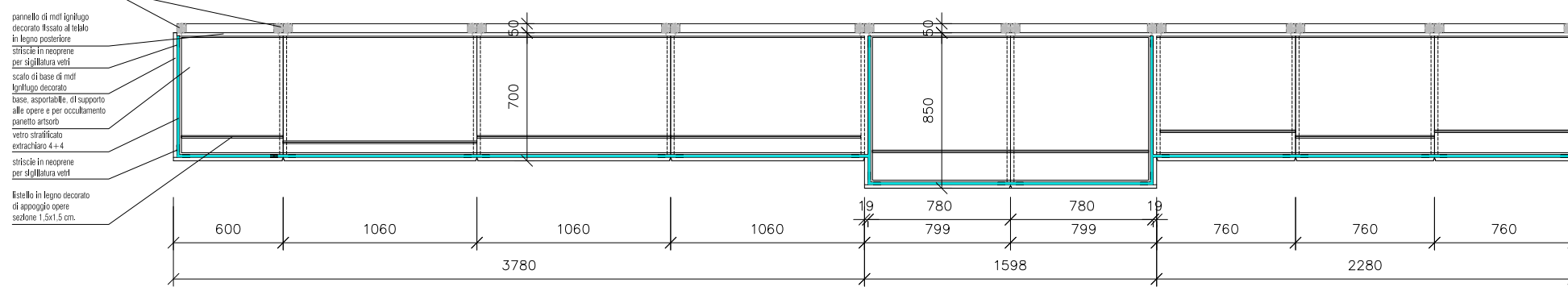

PIANTA A

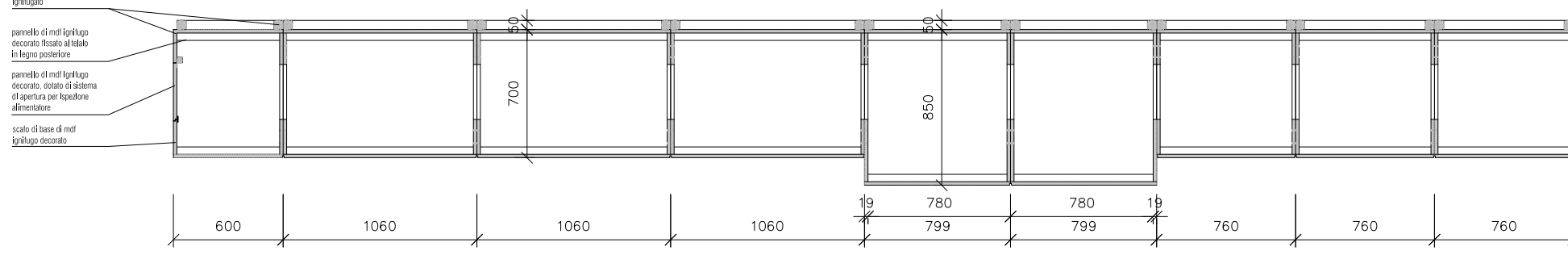

PIANTA C

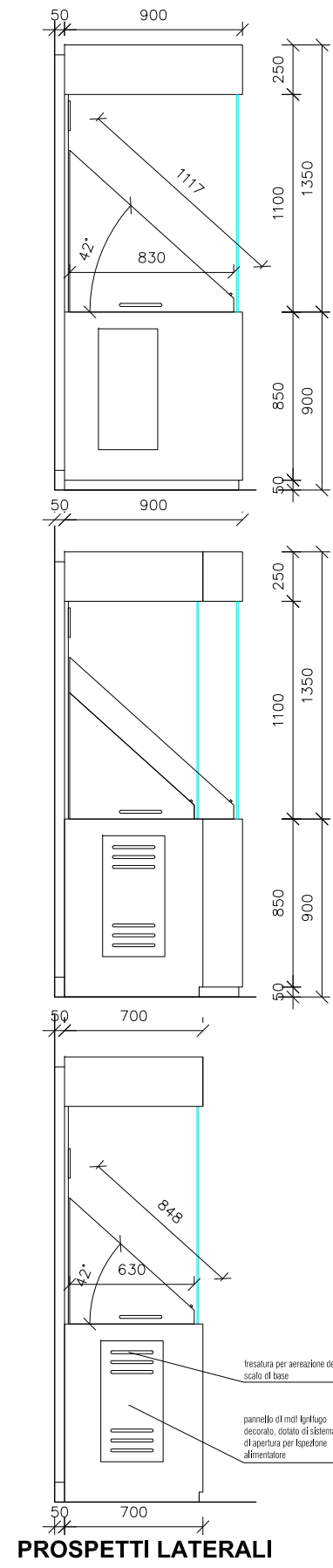
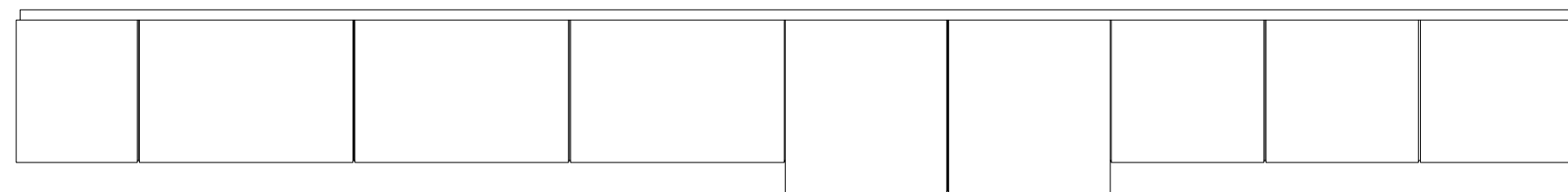

PROSPETTI LATERALI

S5.V01
Teca

Possibile posizione didascalia in forex, spessore 3 mm, con grafica stampata su PVC incollato con nastro biadesivo alla parete della vetrina

base, asportabile, di supporto alle opere e per occultamento pannello artistico

Estello in legno decorato di appoggio opere sezione 1.5x1.5 cm.

fresata sulla base asportabile per climatizzazione vetrina

tabella di irrigimento in legno massello lgrifugato

pannello di mol lgrifugo decorato fissato al tabella in legno posteriore

stiscie in neoprene per sigillatura vetri

scalo di base di mol lgrifugo decorato

base, asportabile, di supporto alle opere e per occultamento pannello artistico

pannello artistico

vetro stratificato antiriflesso 4+4

stiscie in neoprene per sigillatura vetri

Estello in legno decorato di appoggio opere sezione 1.5x1.5 cm.

tabella di irrigimento in legno massello lgrifugato

pannello di mol lgrifugo decorato fissato al tabella in legno posteriore

pannello di mol lgrifugo decorato, dotato di sistema di apertura per ispezione alimentatore

scalo di base di mol lgrifugo decorato

fresatura per aerazione dello scalo di base

pannello di mol lgrifugo decorato, dotato di sistema di apertura per ispezione alimentatore

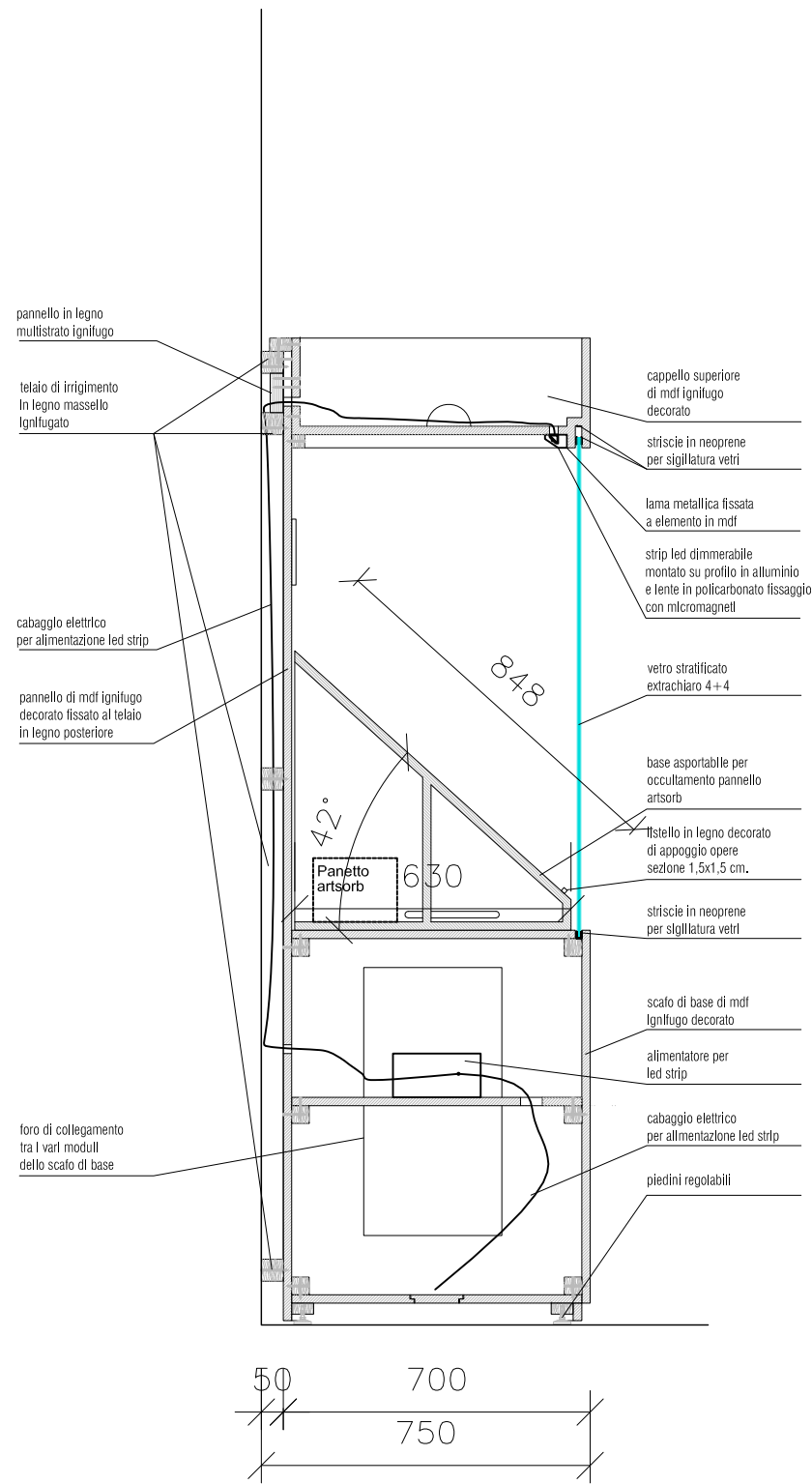

SEZIONE D

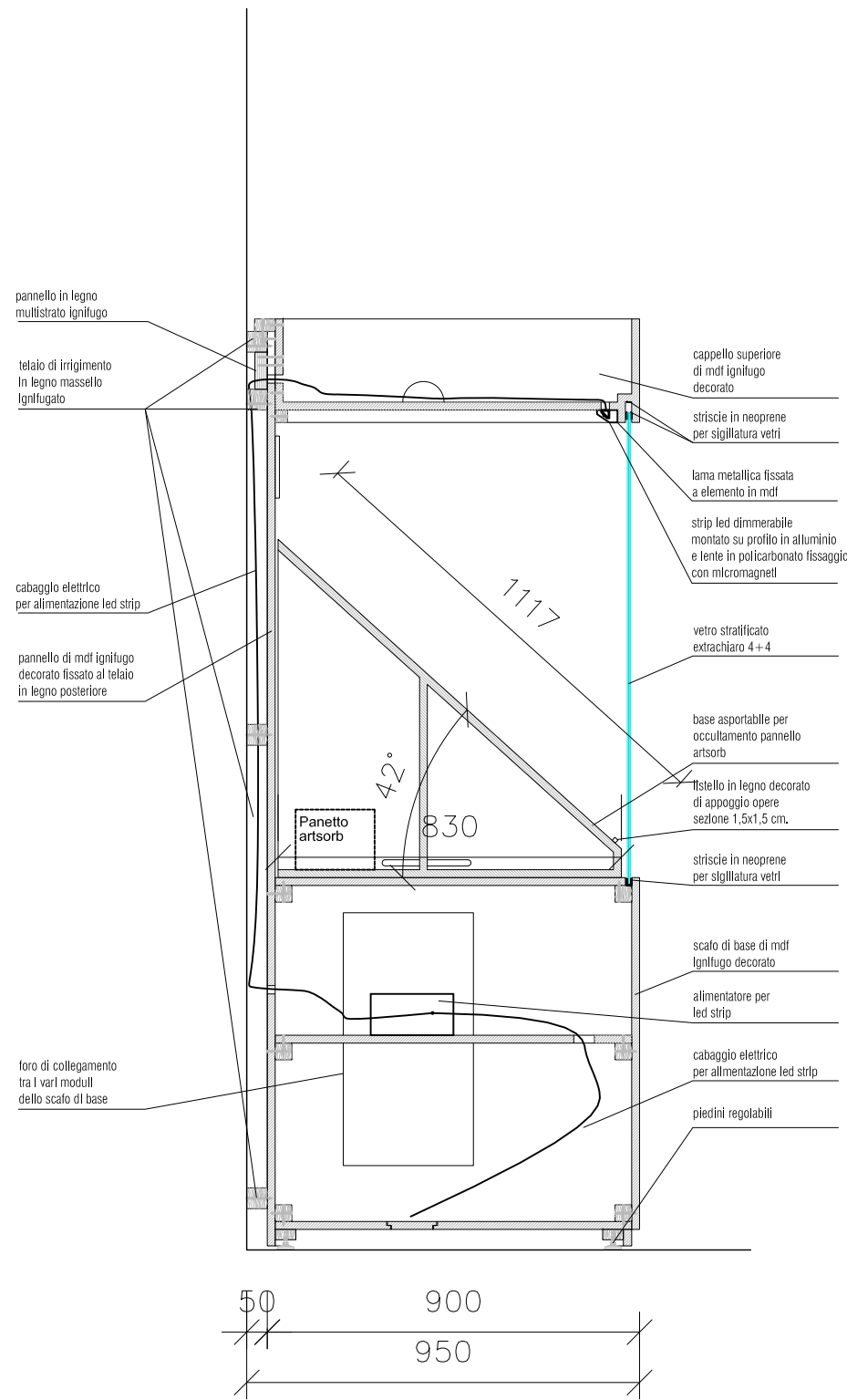

SEZIONE E

DETTAGLIO SIGILLATURA VETRI

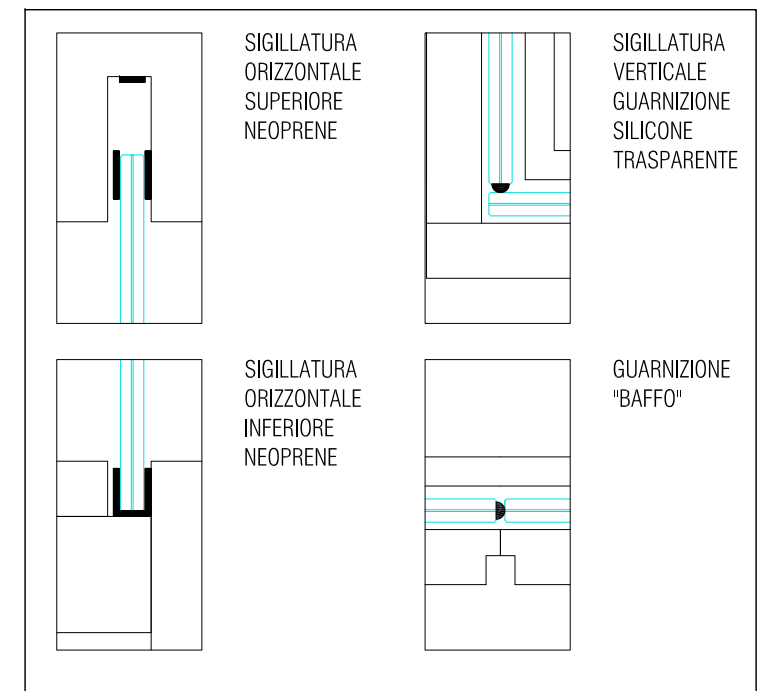

S5.V01
Teca

PIANTA C

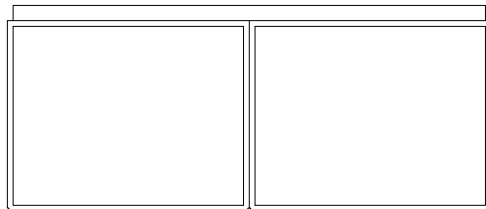

PIANTA B

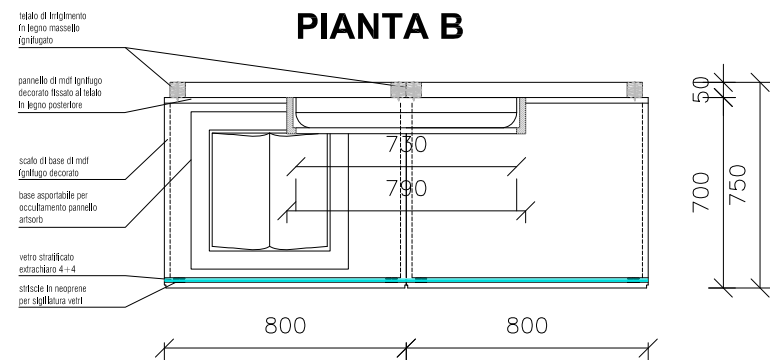

PIANTA A

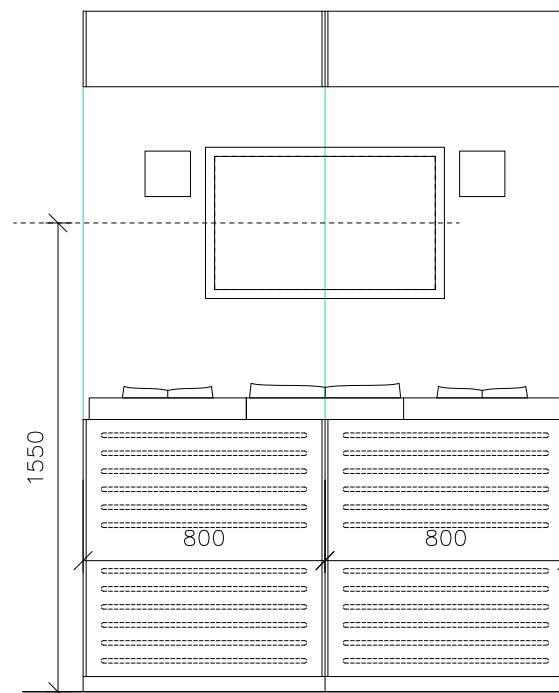
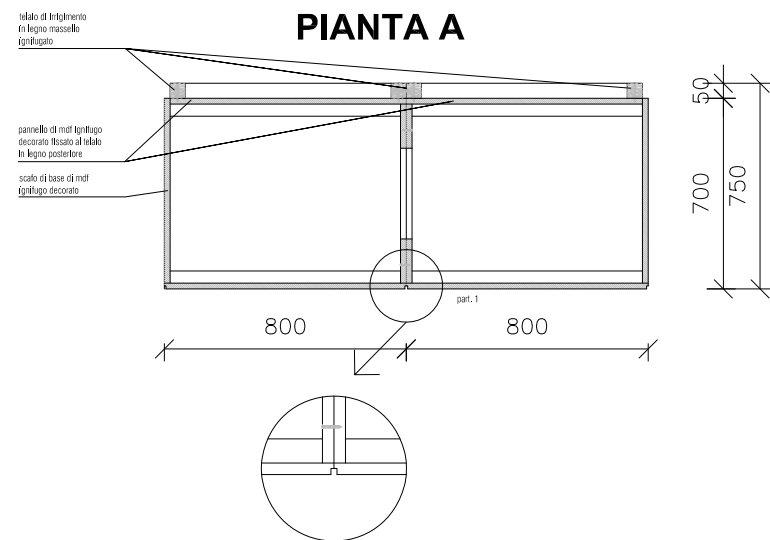

PROSPETTO FRONTALE

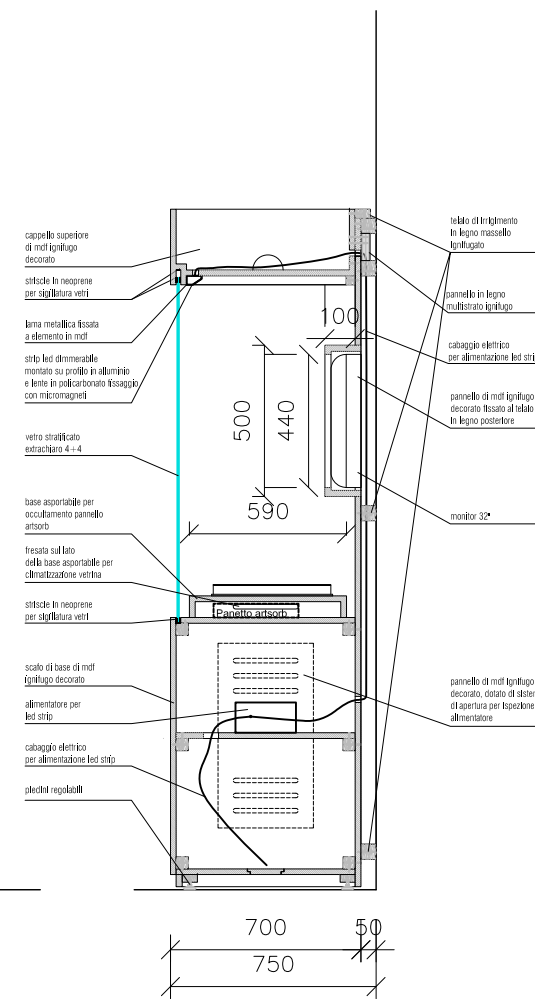

SEZIONE D

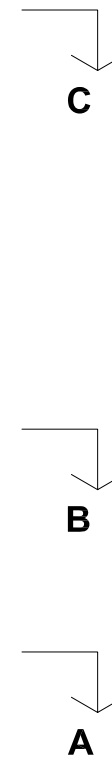

DETTAGLIO SIGILLATURA VETRI

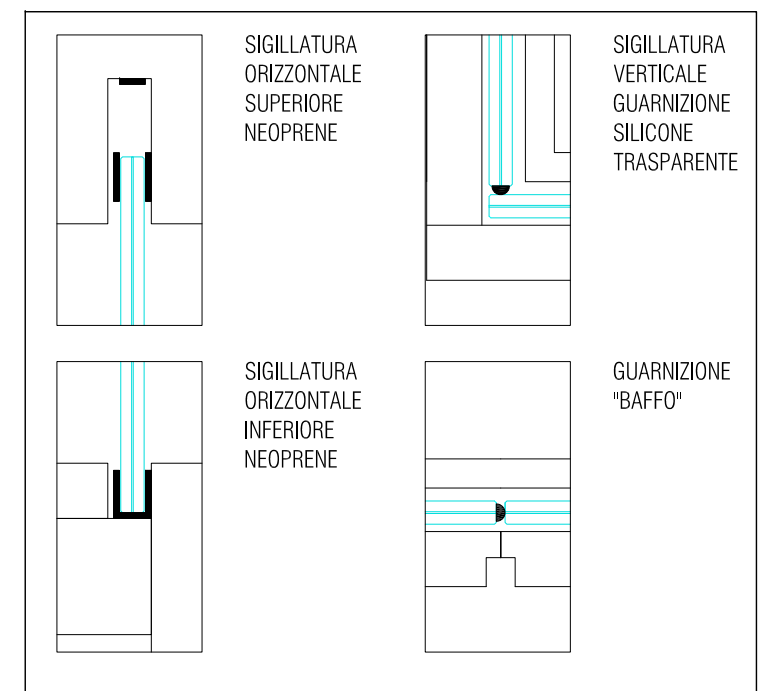

S5.V02
Teca

PROSPETTO FRONTALE

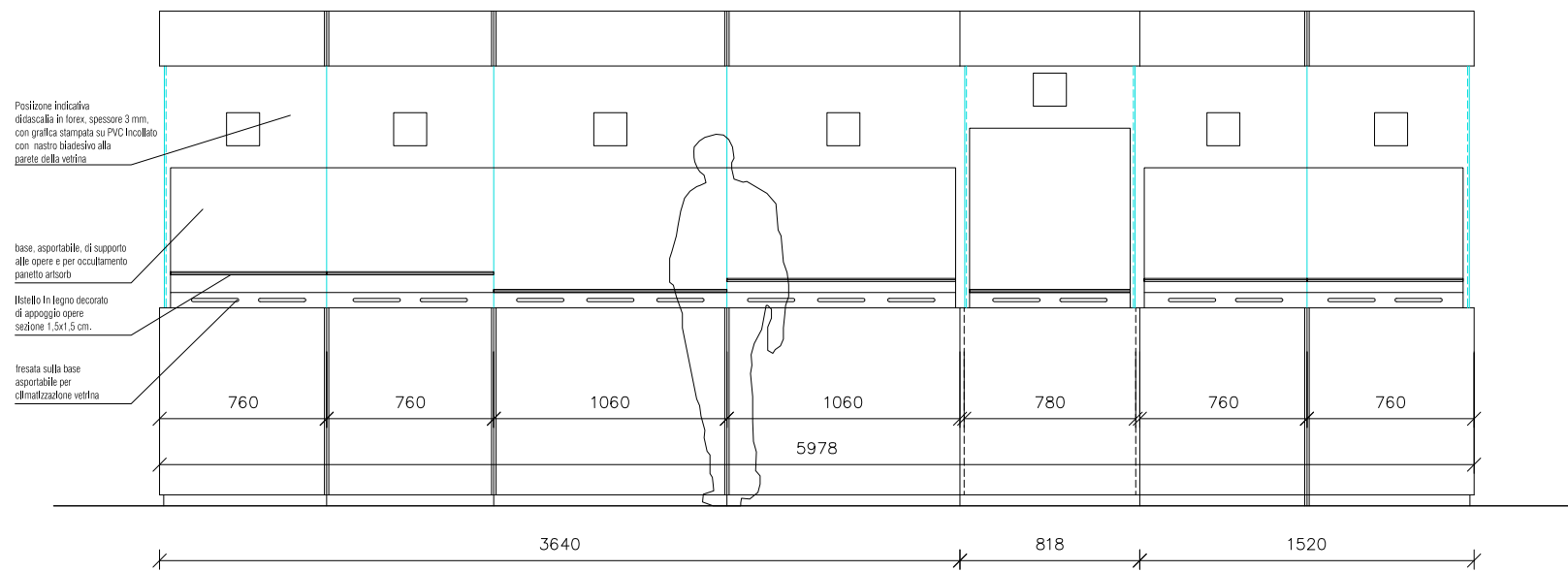

PIANTA B

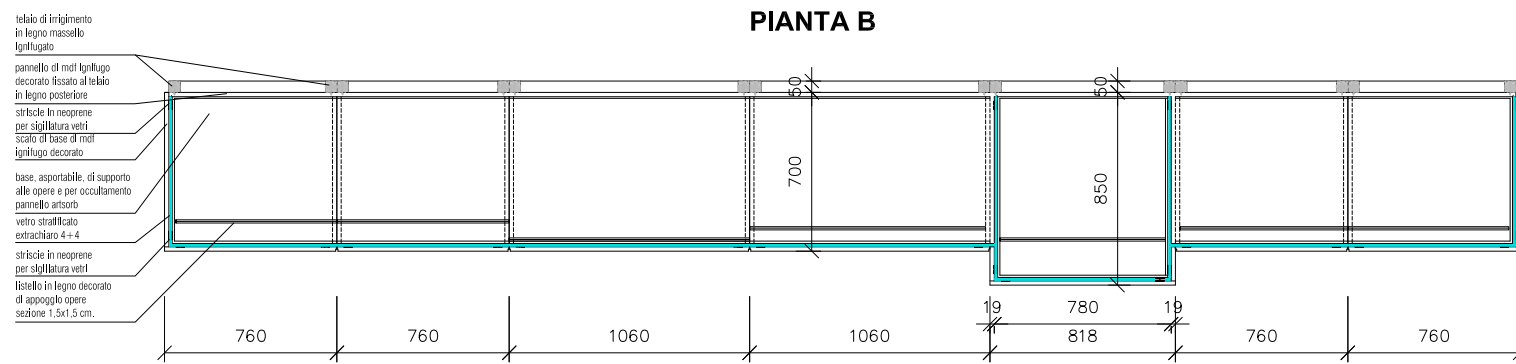

PIANTA A

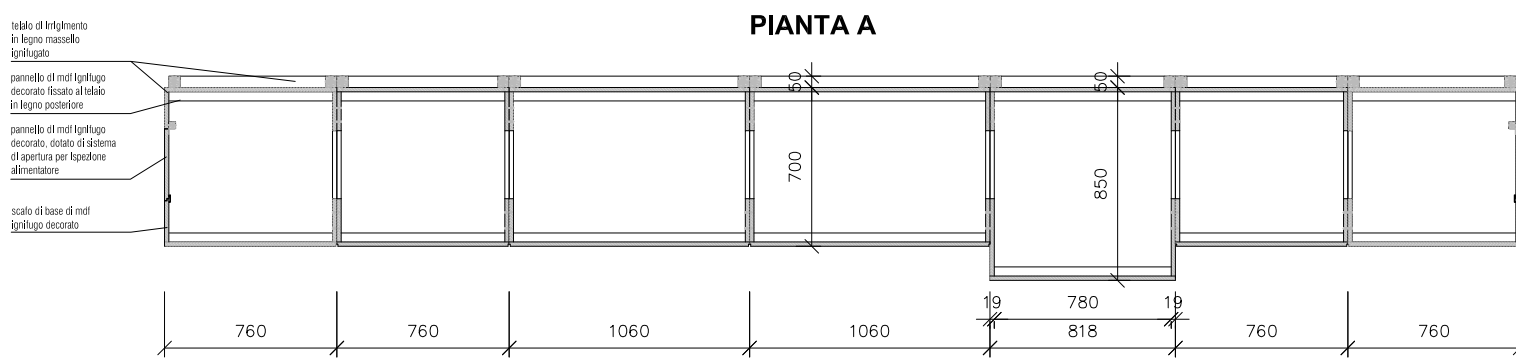

PIANTA C

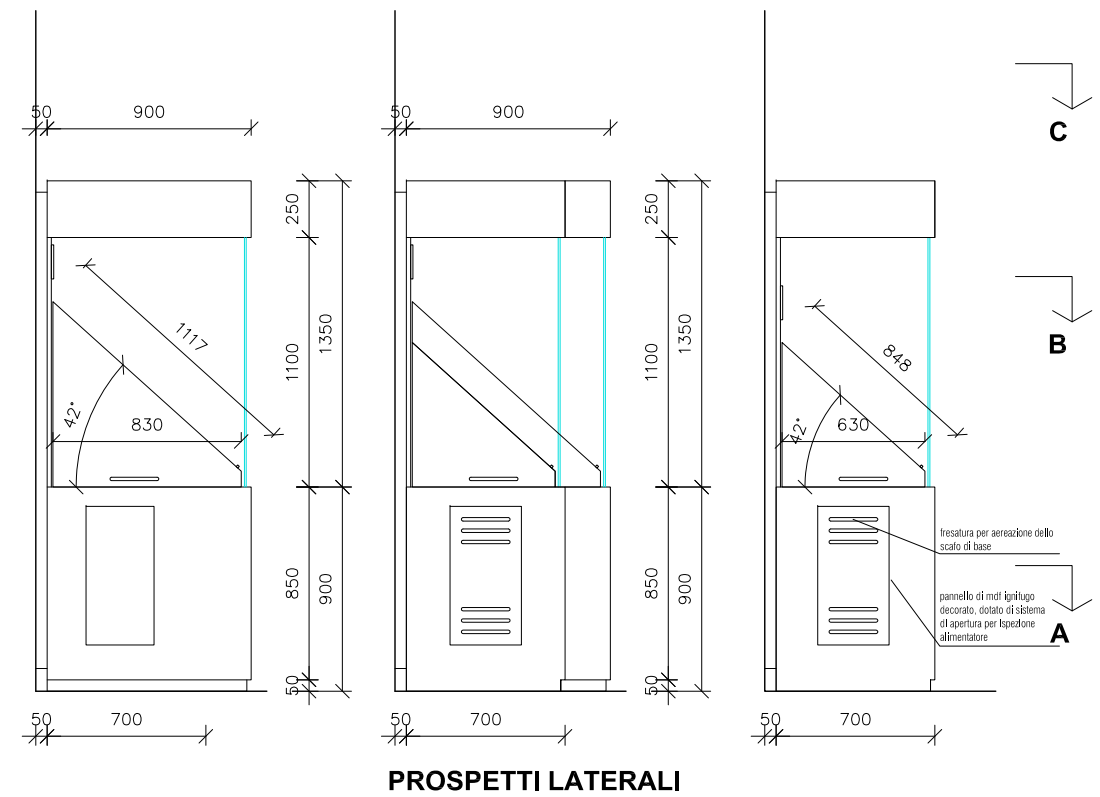
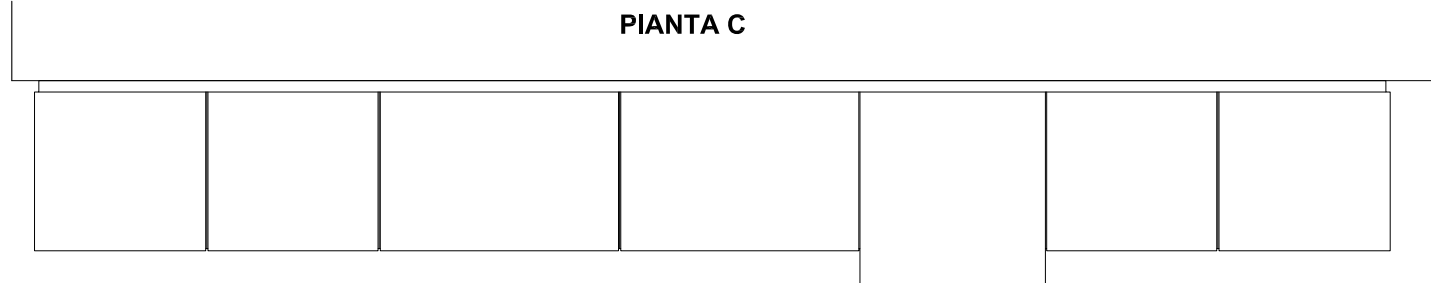

S5.V03
Teca

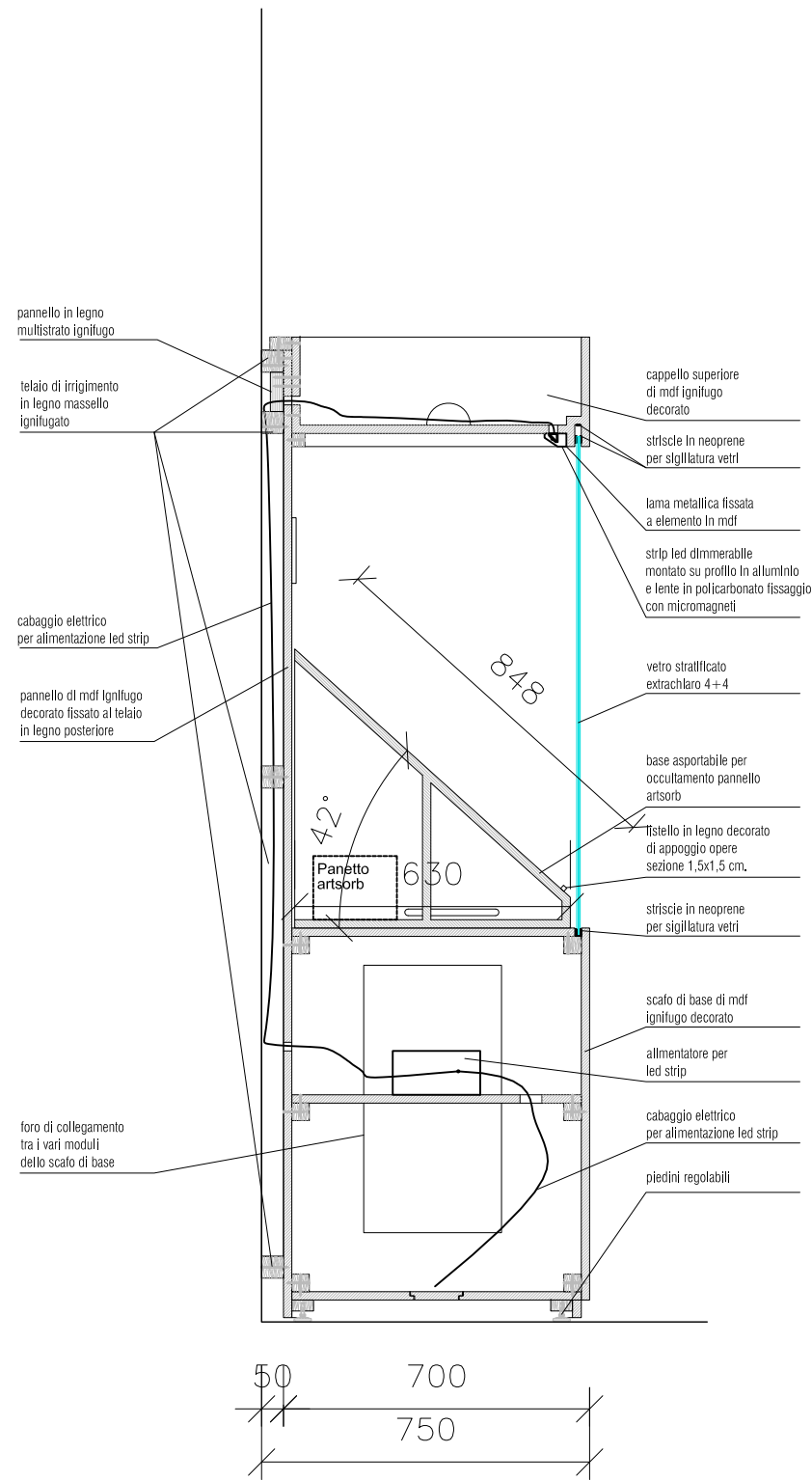

SEZIONE D

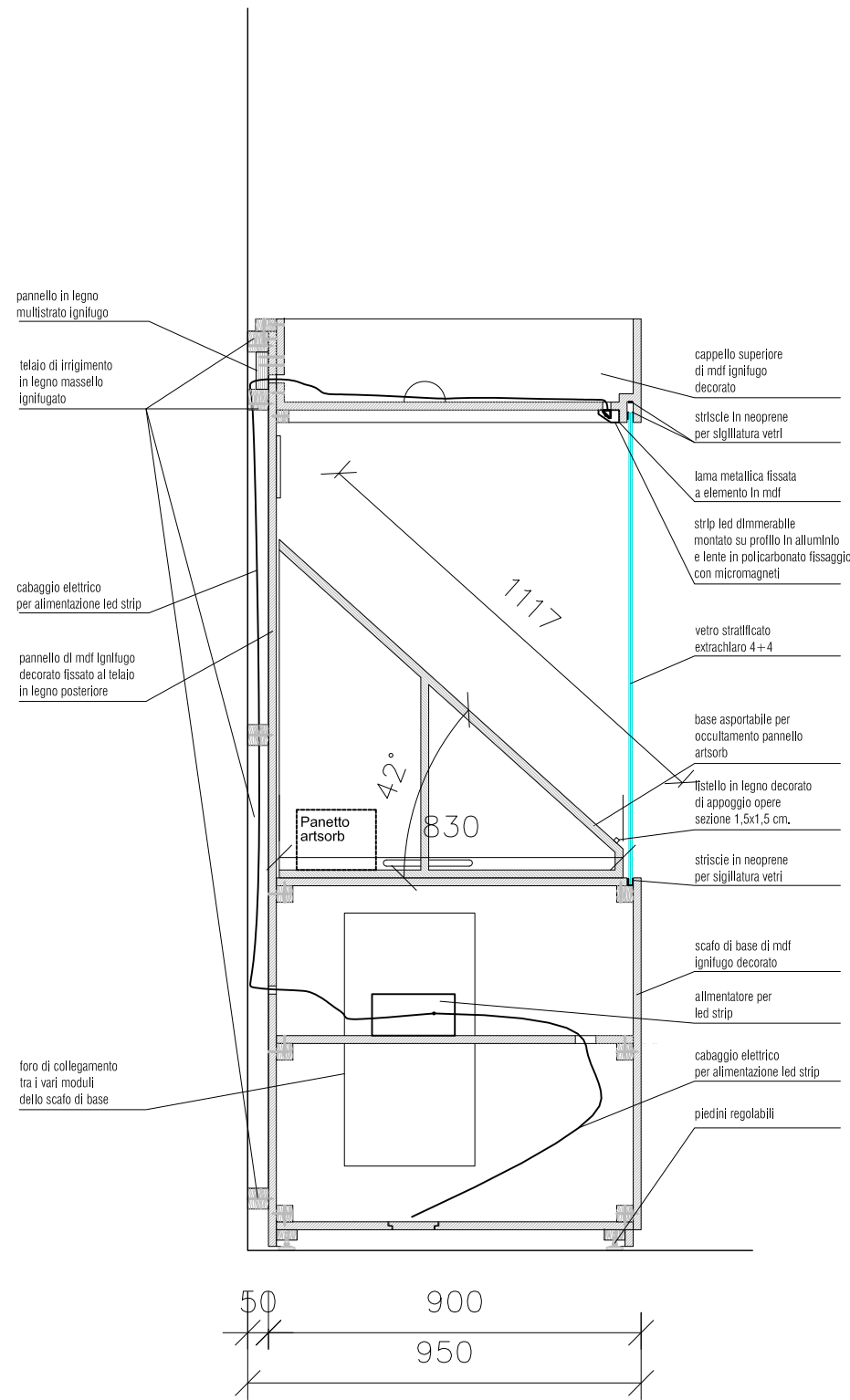

SEZIONE E

DETTAGLIO SIGILLATURA VETRI

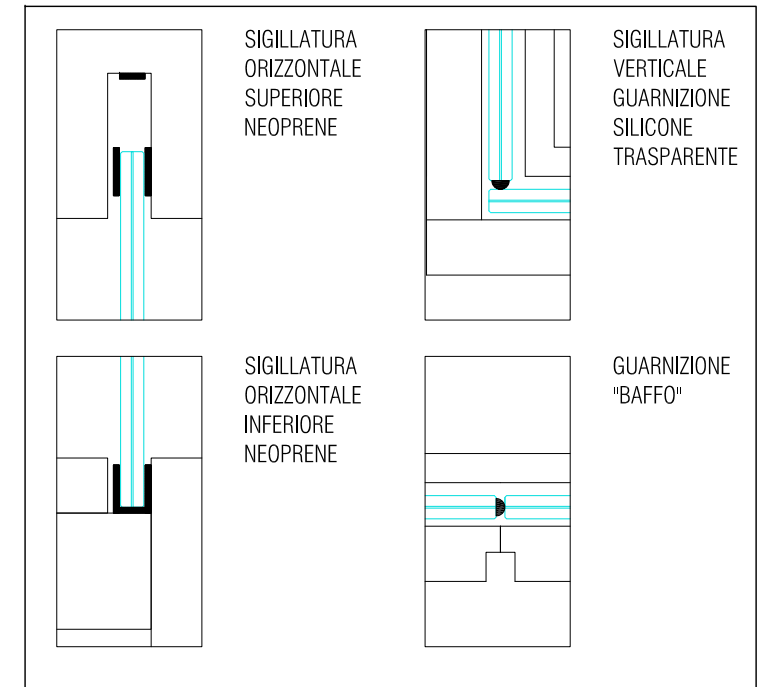

S5.V03
Teca

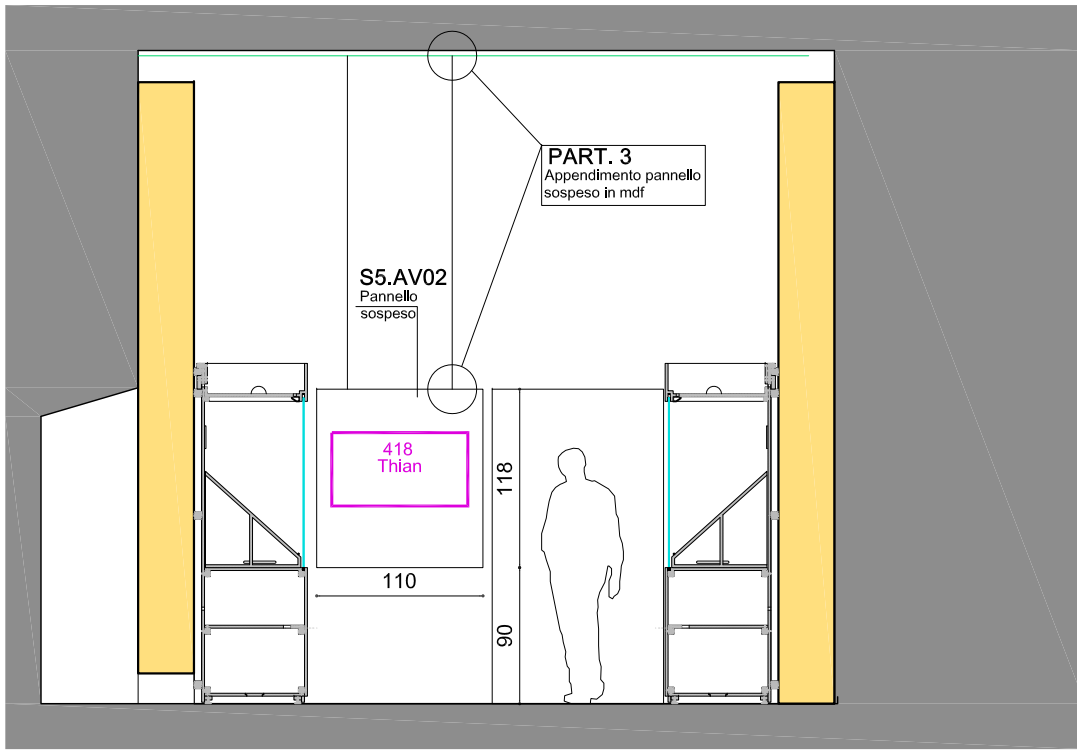

Parete 4

PART. 1
Fissaggio canvas alla parete in mdf del molo

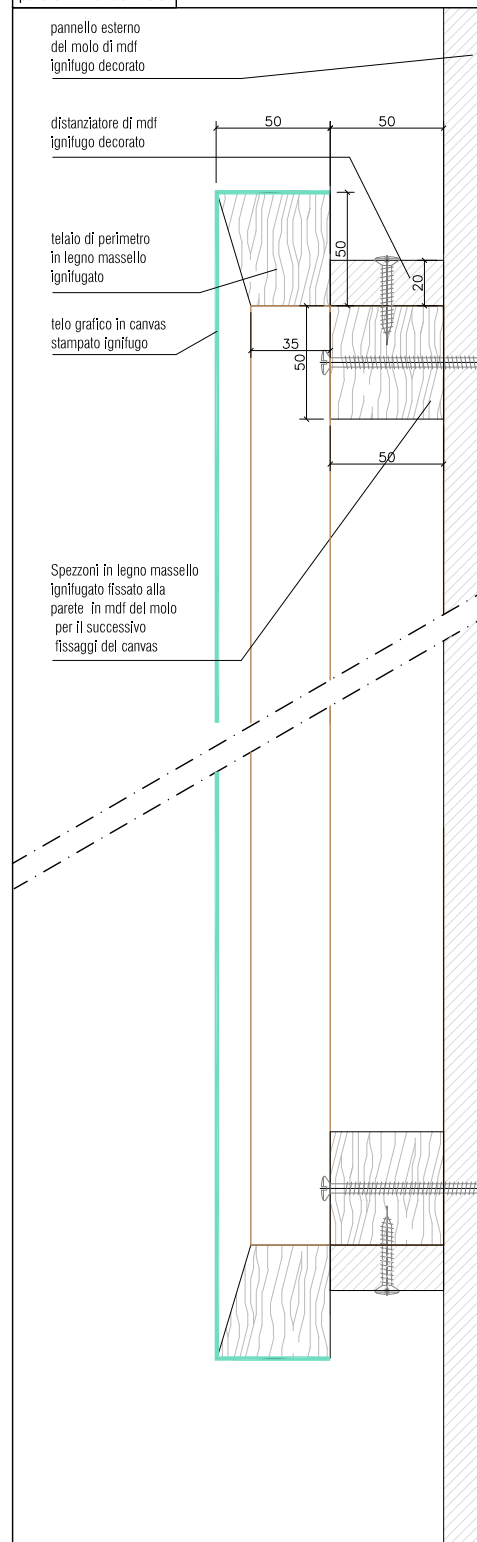

S5.C01
Telaio ligneo sparapuntato con telo grafico realizzato in masselli di legno ignifugato

S5.F01
Doppio pannello in piuma spessore 20 mm

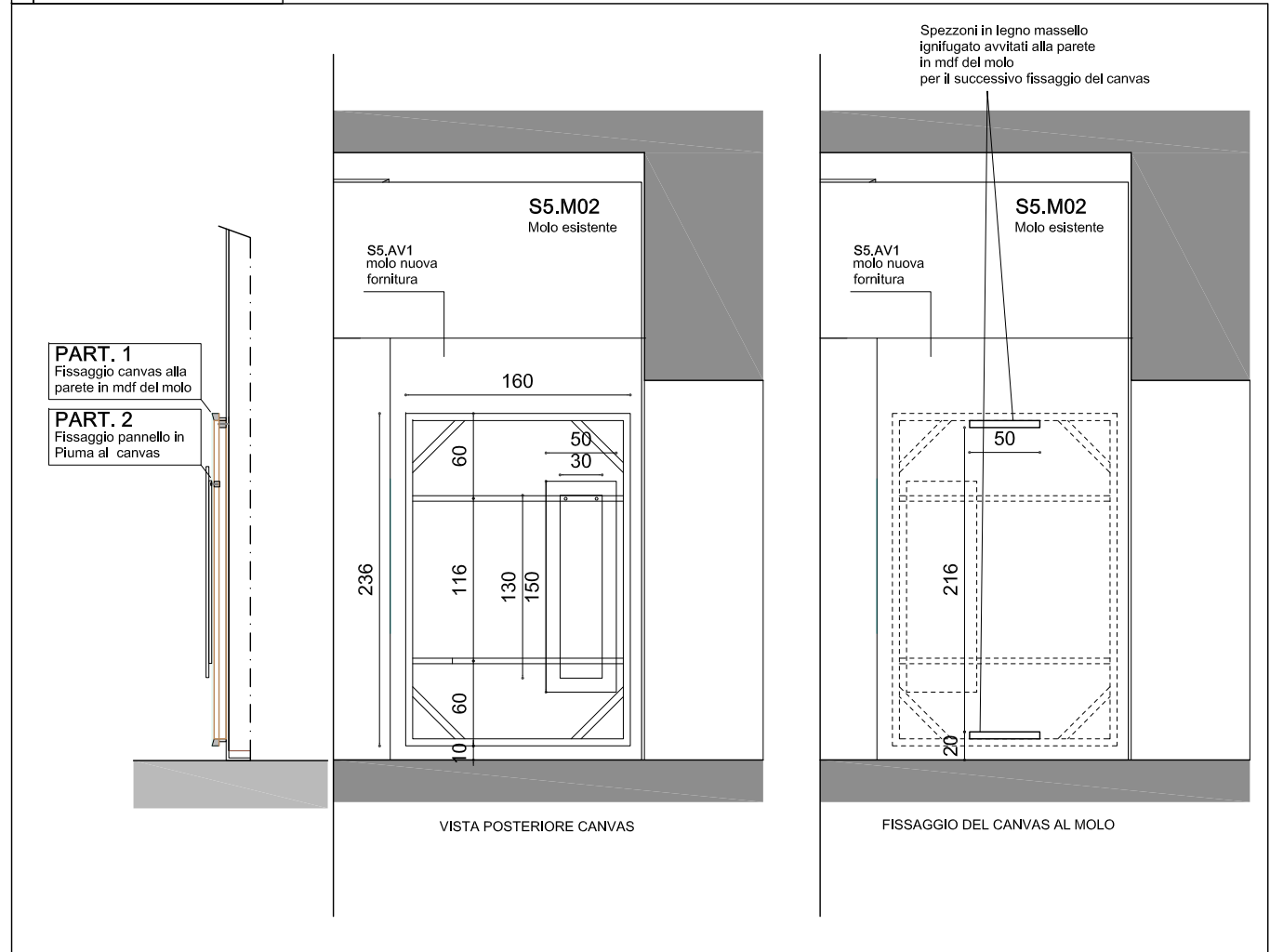

PART. 3
Appendimento pannello sospeso in mdf

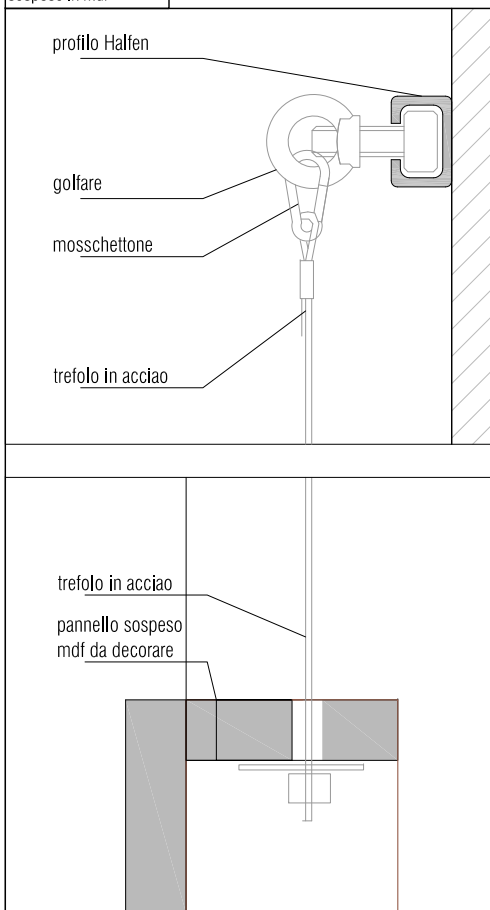

PART. 2
Fissaggio pannello in Piuma al canvas

