



La Venaria Reale

CONSORZIO DI VALORIZZAZIONE CULTURALE

**PROGETTO DI ALLESTIMENTO DELLA MOSTRA
"FATTO IN ITALIA"**

PIANO SECONDO SALE DELLE ARTI

**OGGETTO:
ELABORATI GRAFICI**

E.G.

RESPONSABILE DEL PROCEDIMENTO

Gianbeppe Colombano

PROGETTO DI ALLESTIMENTO: arch. Giovanni Tironi



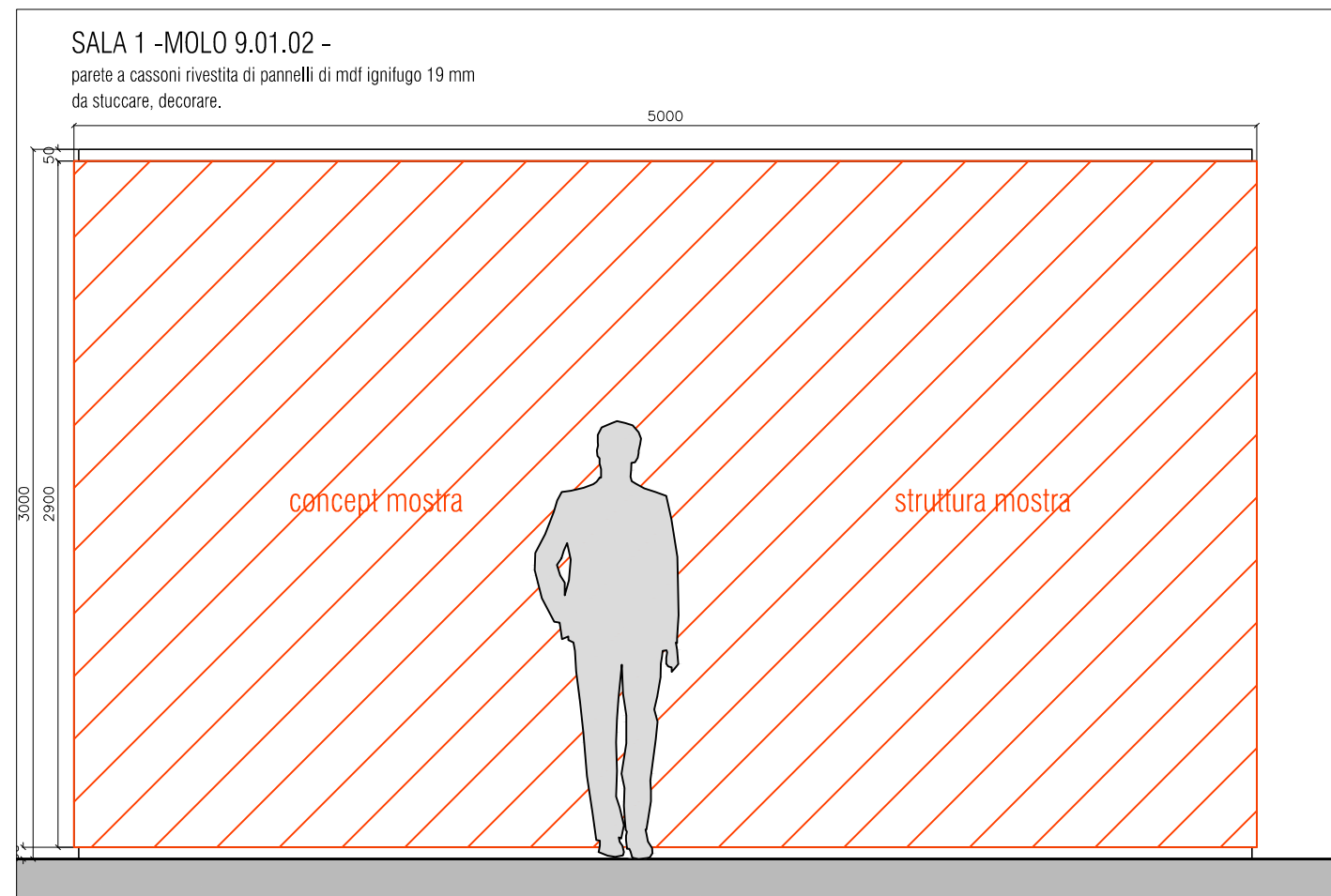
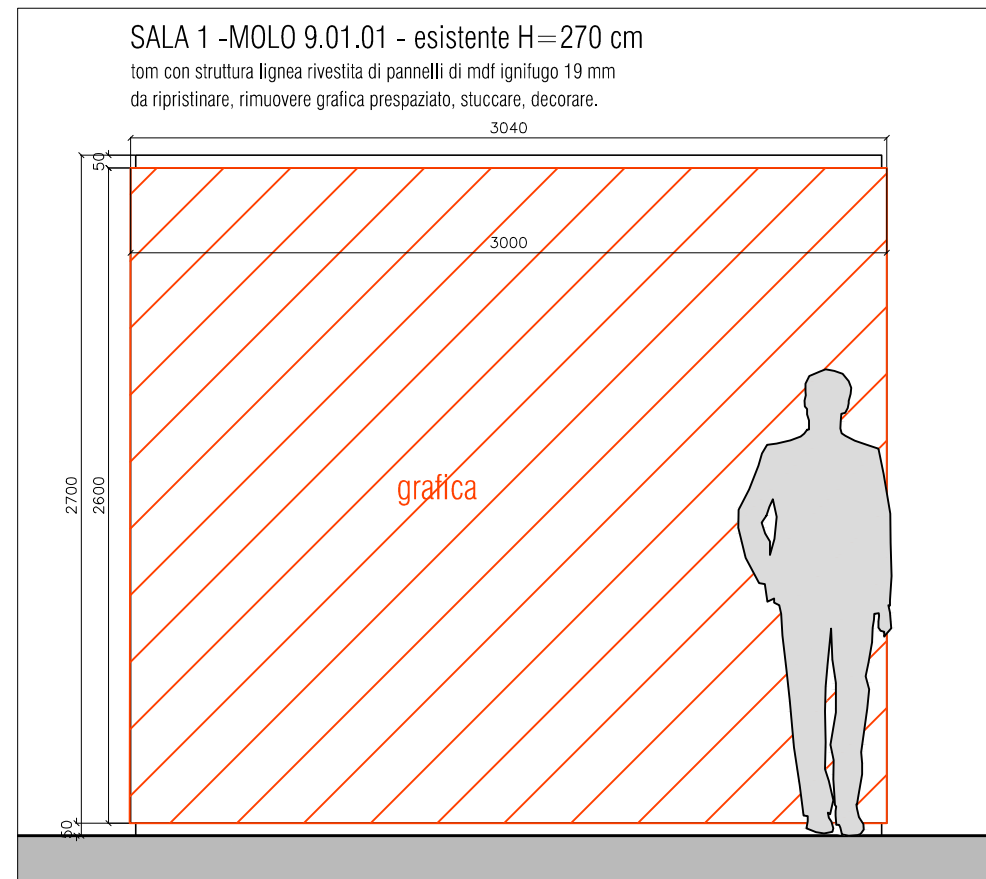
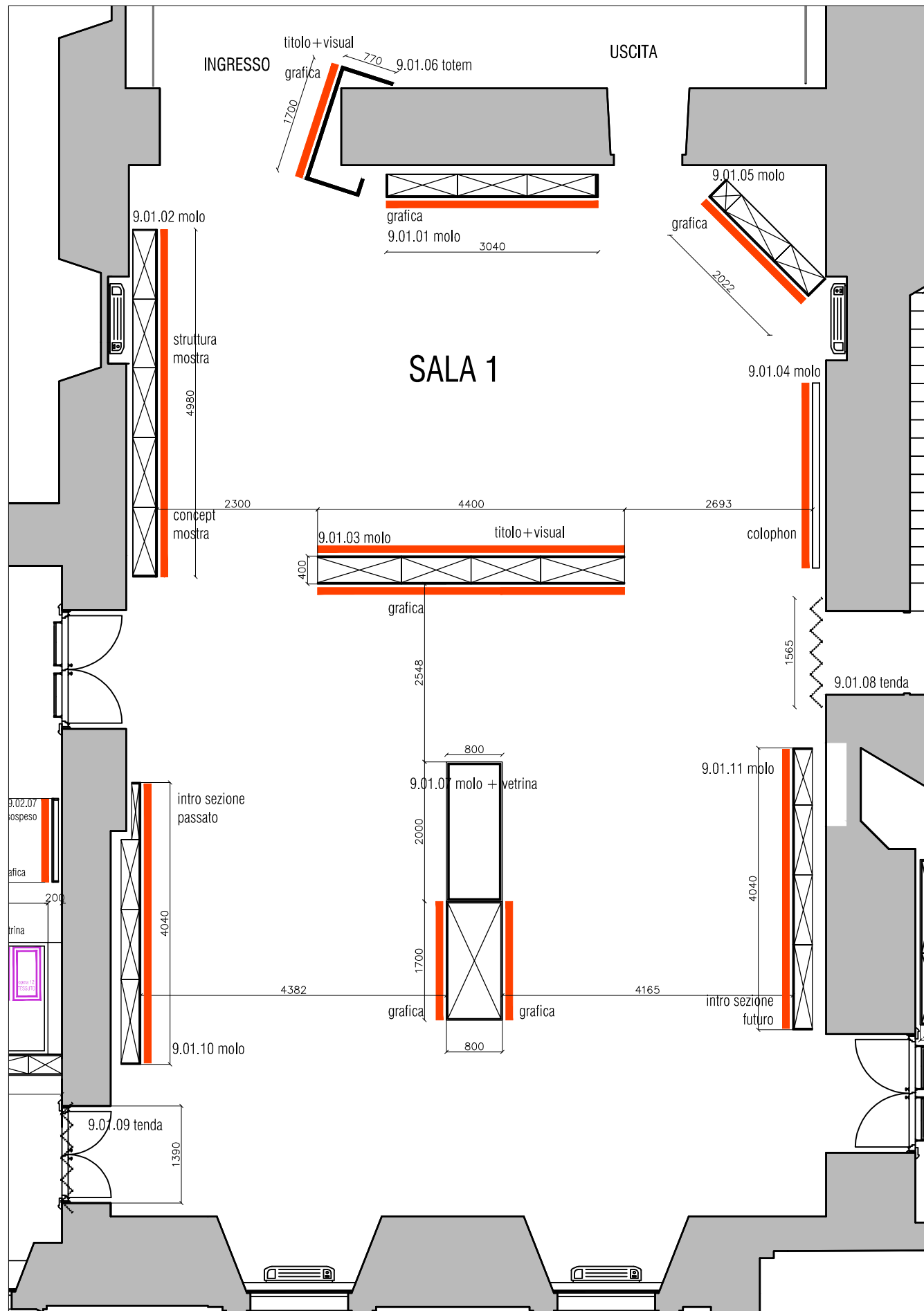

SALA 1 -MOLO 9.01.04- esistente H=330cm
con struttura lignea rivestita di pannelli di mdf ignifugo 19 mm
da ripristinare, stuccare, decorare.

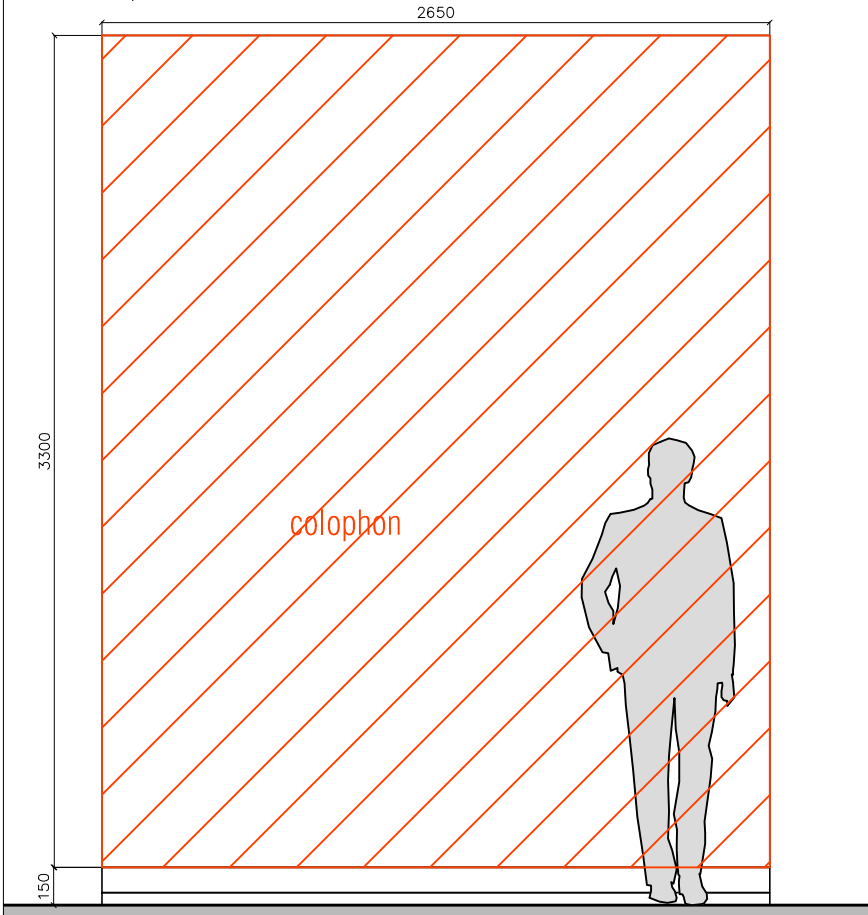

SALA 1 -MOLO 9.01.03 -
parete a cassoni bifacciale, nuova fornitura rivestita di pannelli di mdf ignifugo 19 mm
da stuccare, decorare.

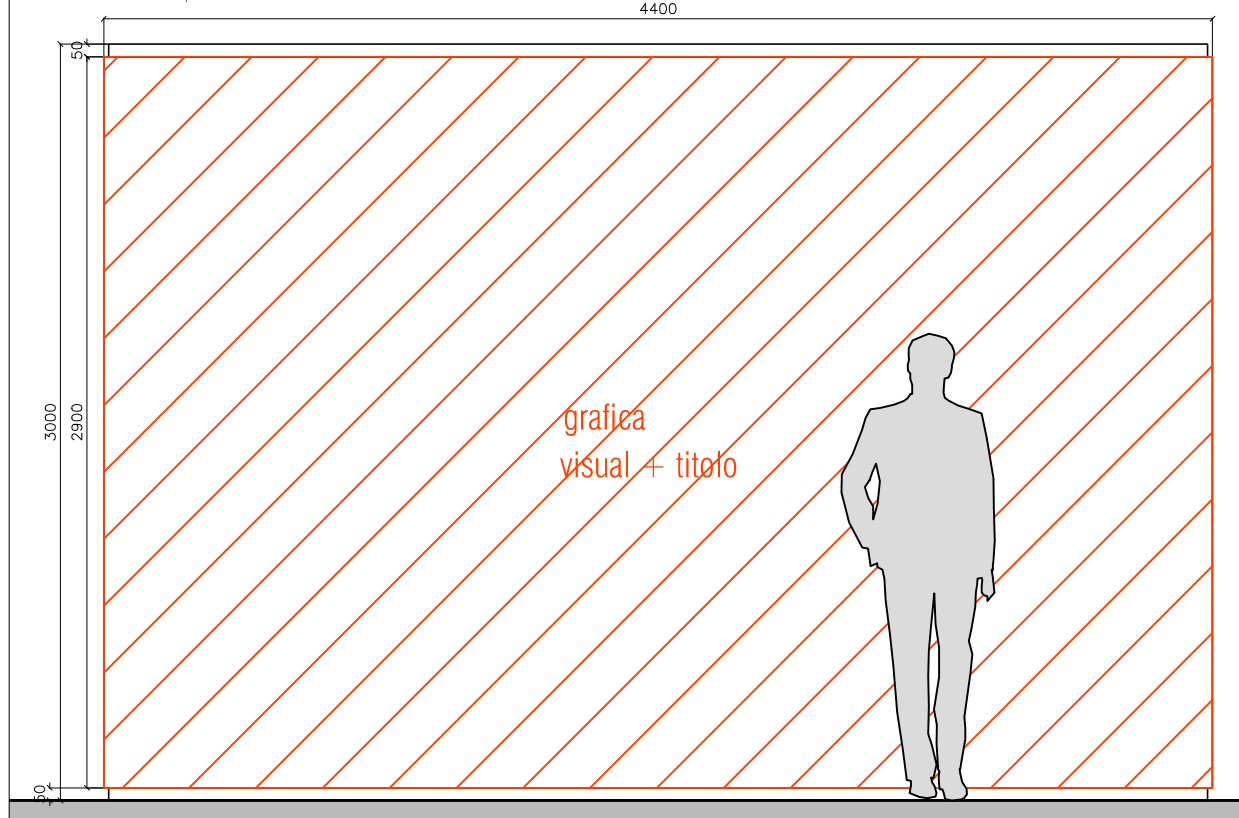

Totem 9.01.05 - molo esistente

totem con struttura lignea rivestita di pannelli di mdf ignifugo 19 mm
da ripristinare, stuccare, decorare.

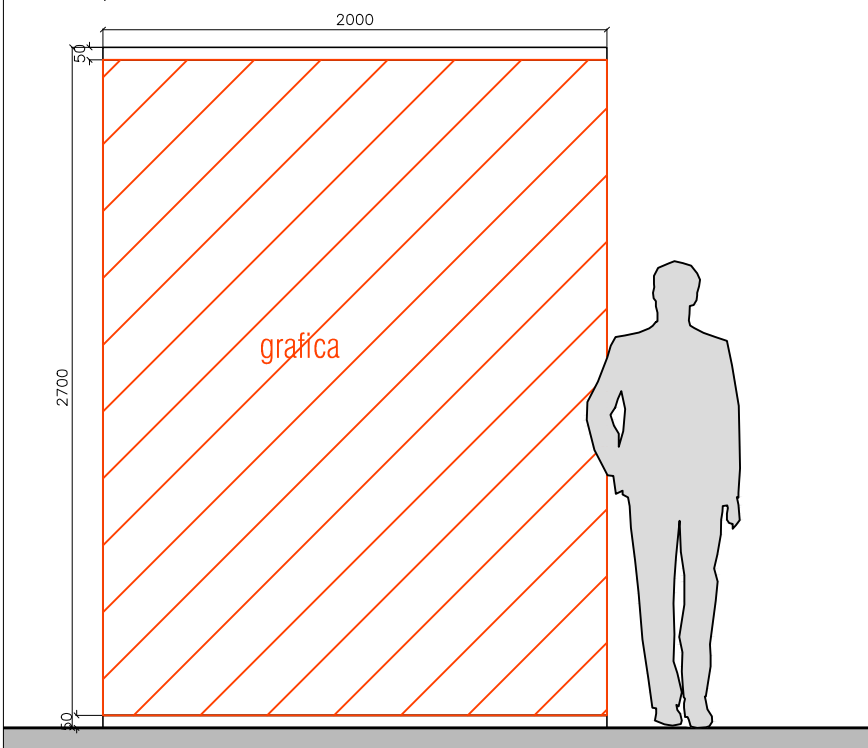

Totem 9.01.06 - ingresso -esistente

totem con struttura lignea rivestita di pannelli di mdf ignifugo 19 mm
da ripristinare, rimuovere grafica prespaziato, stuccare, decorare.

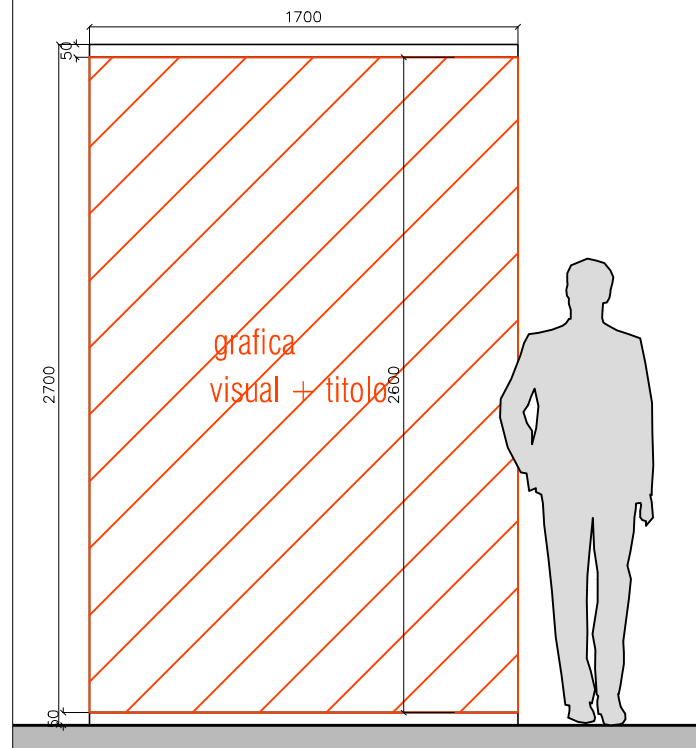

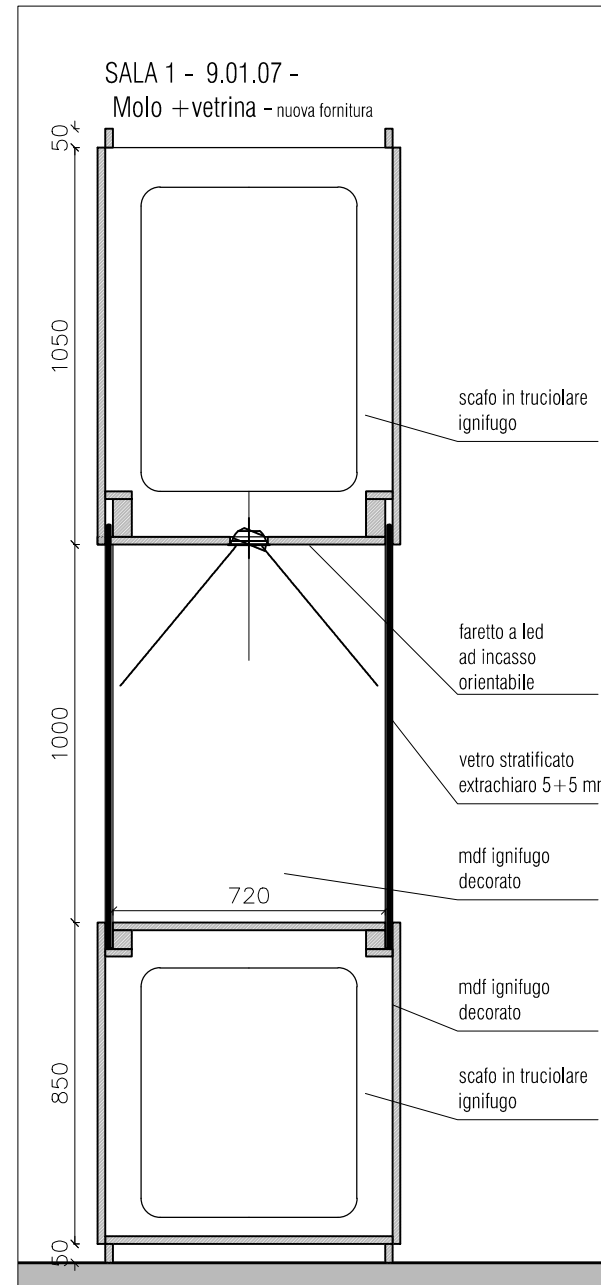
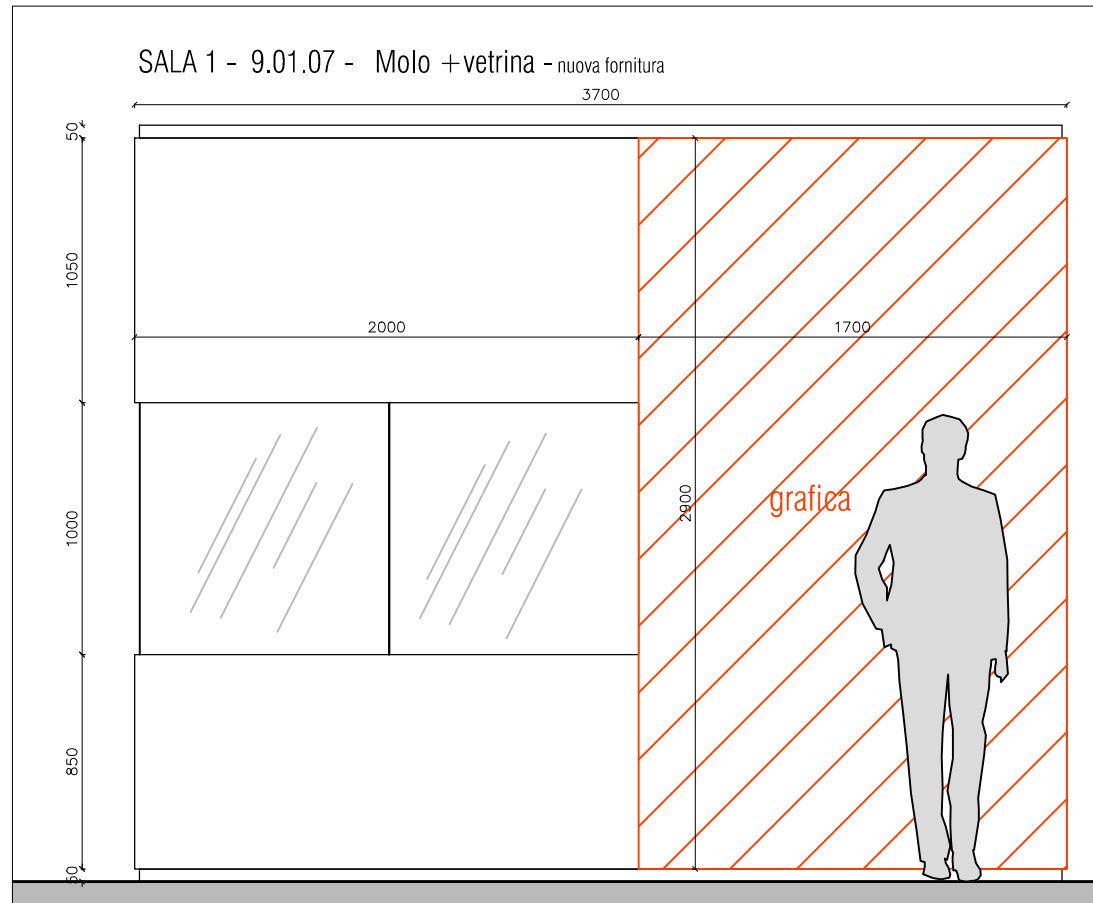

SALA 1 - MOLO 9.01.10 -

parete a cassoni bifacciale, nuova fornitura rivestita di pannelli di mdf ignifugo 19 mm
da stuccare, decorare.

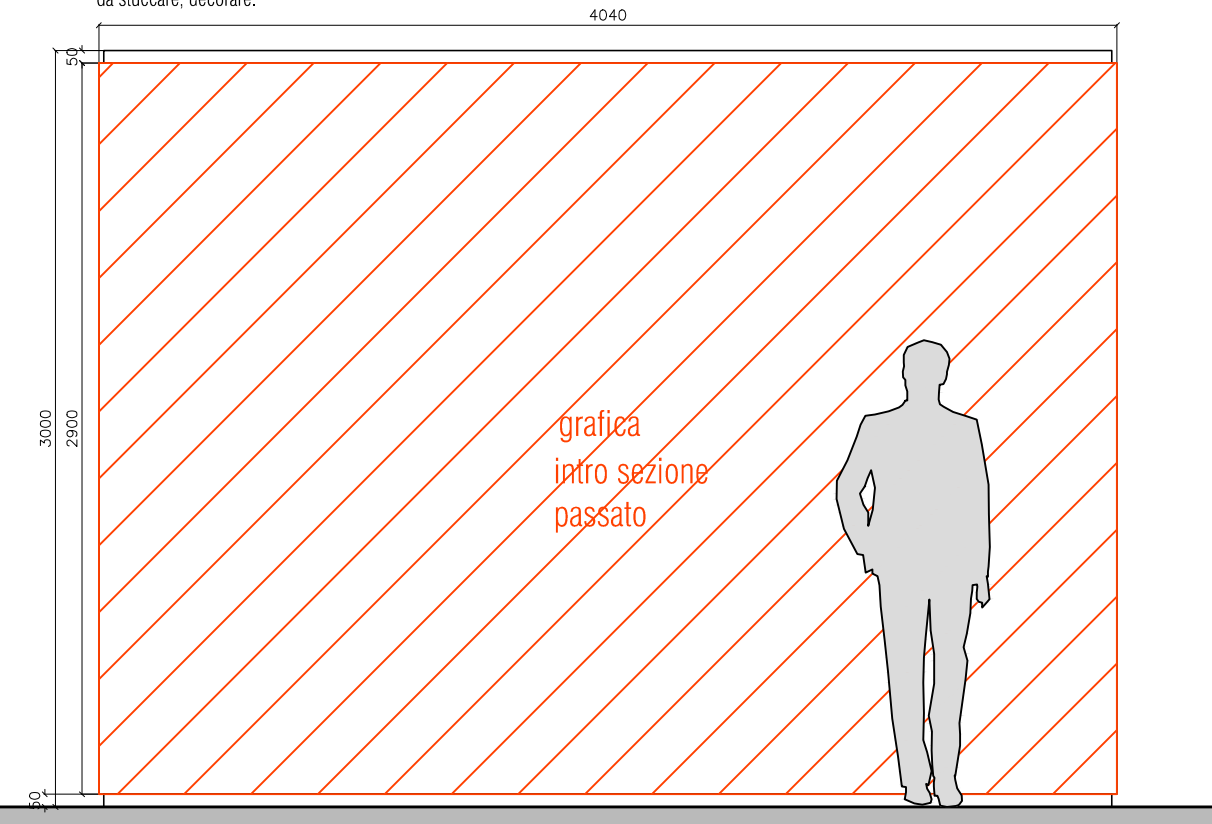

SALA 1 - MOLO 9.01.11 -

parete a cassoni bifacciale, nuova fornitura rivestita di pannelli di mdf ignifugo 19 mm
da stuccare, decorare.

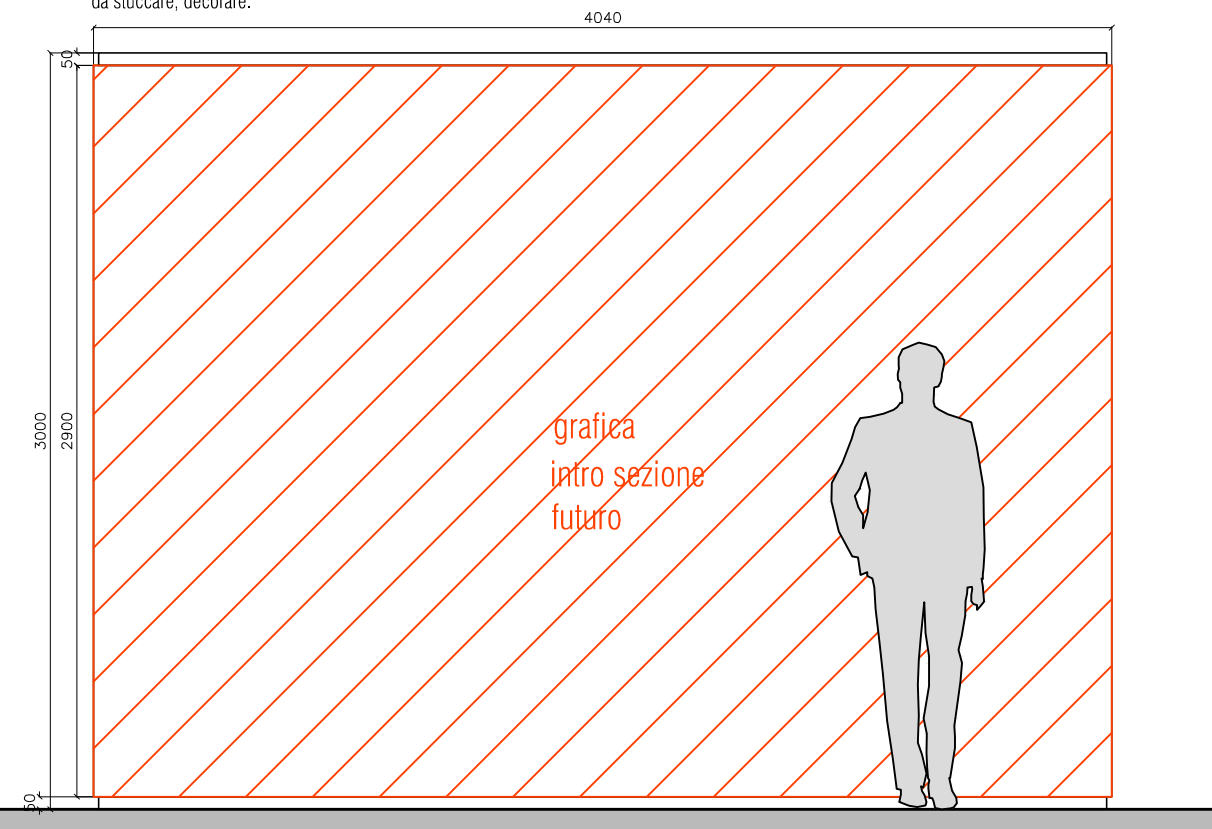

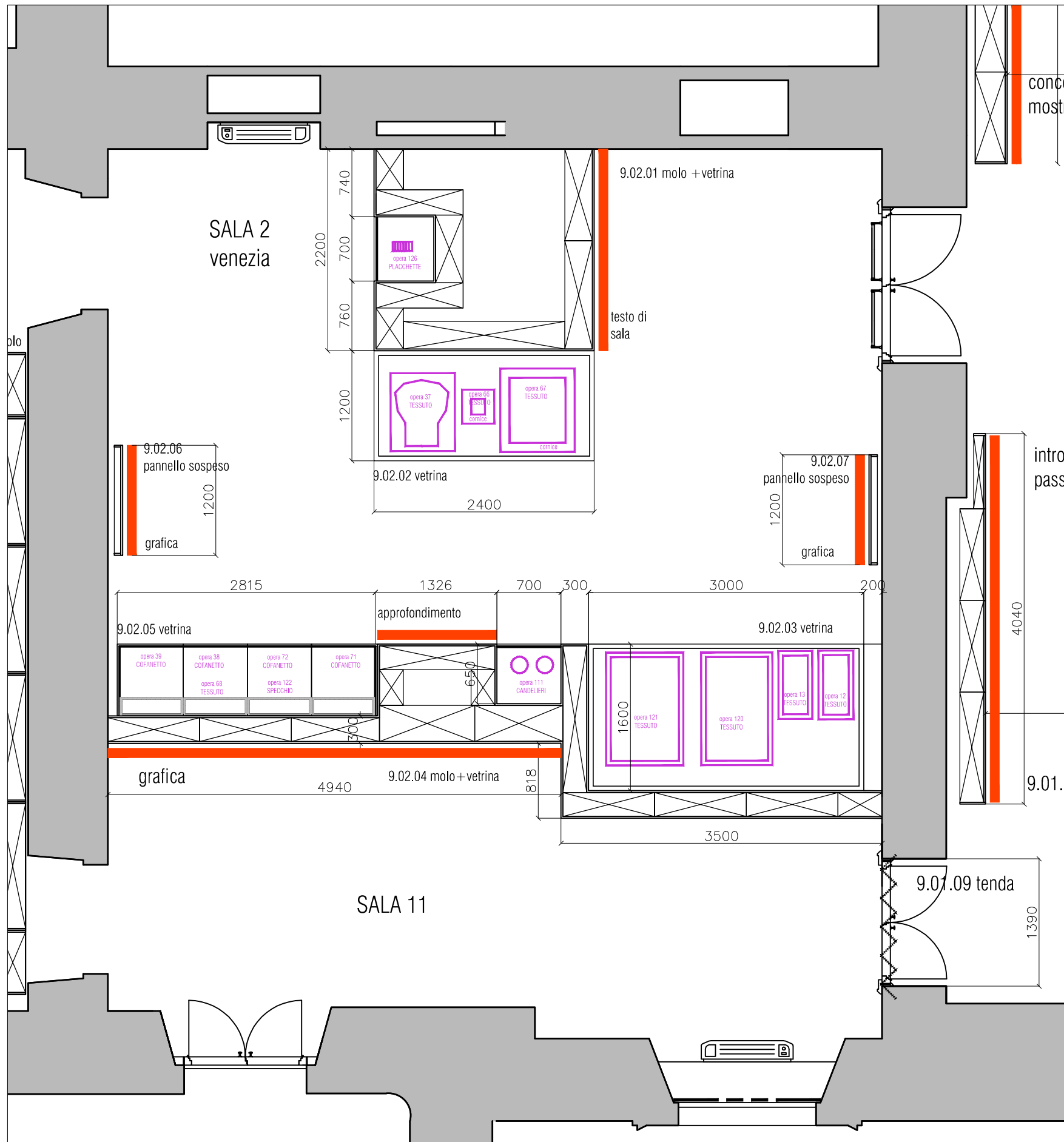

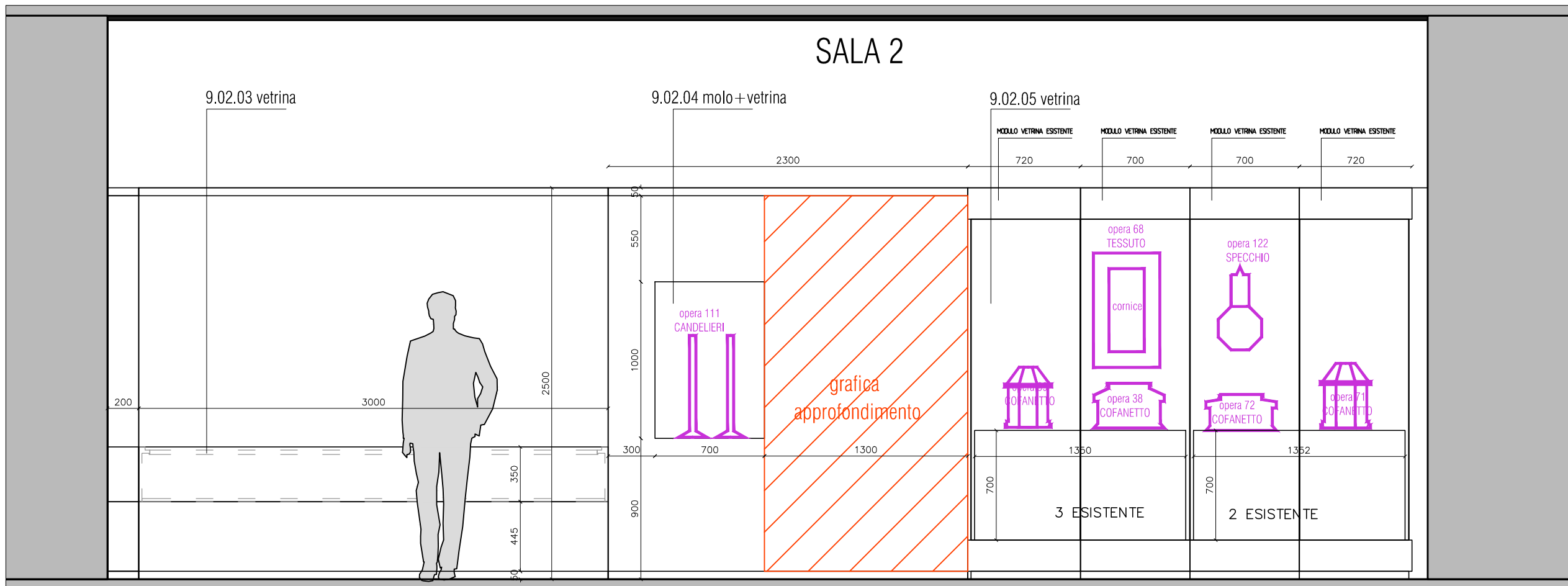
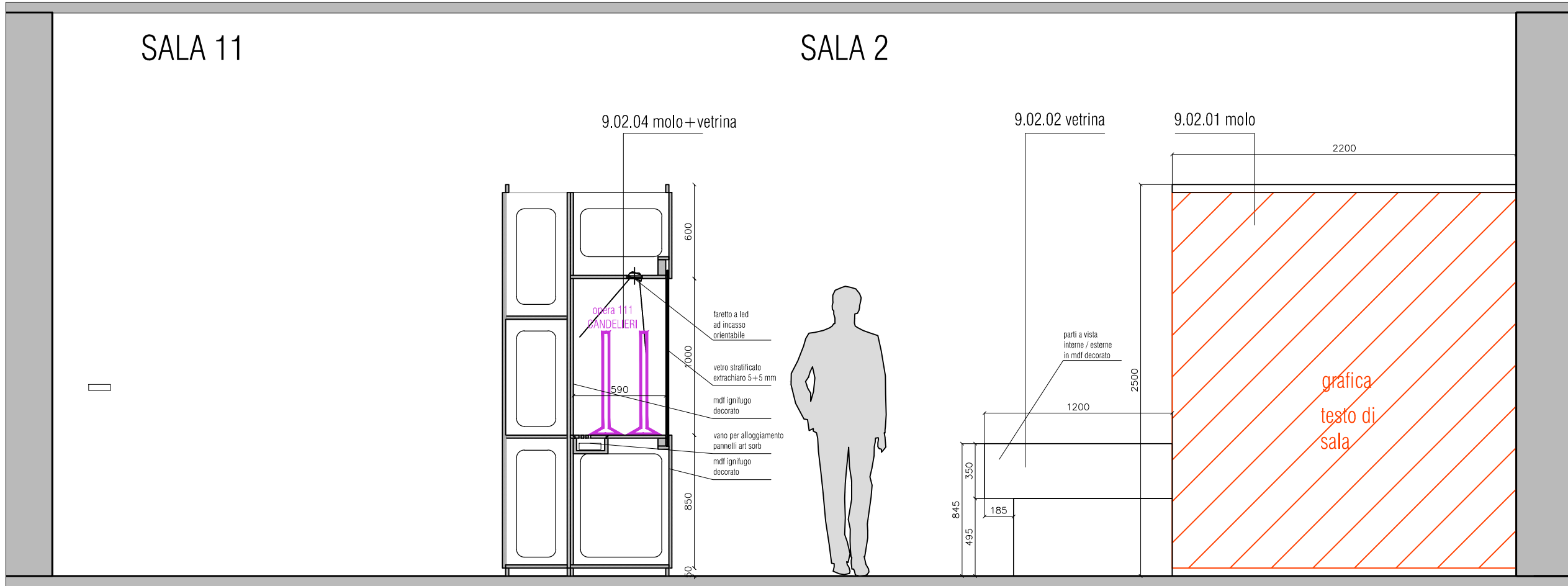

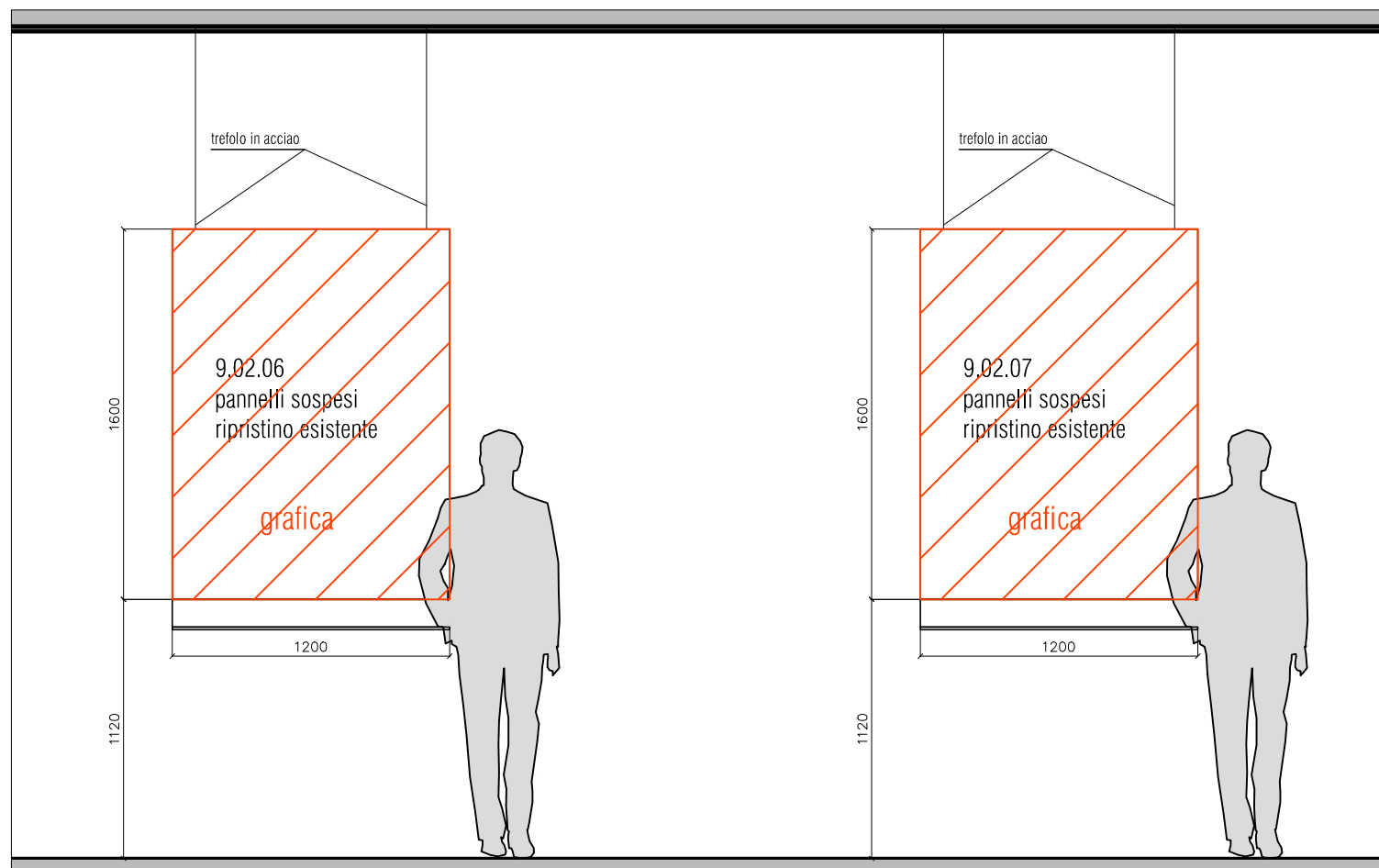
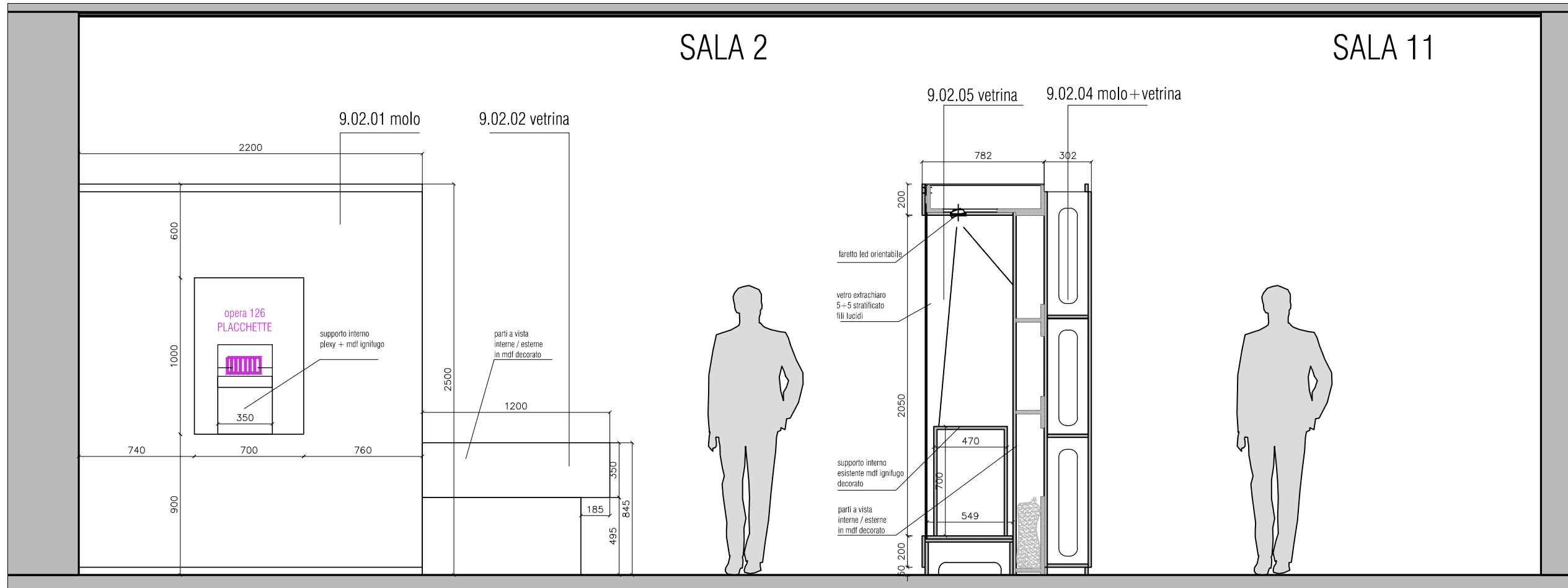

9.02.02 vetrina

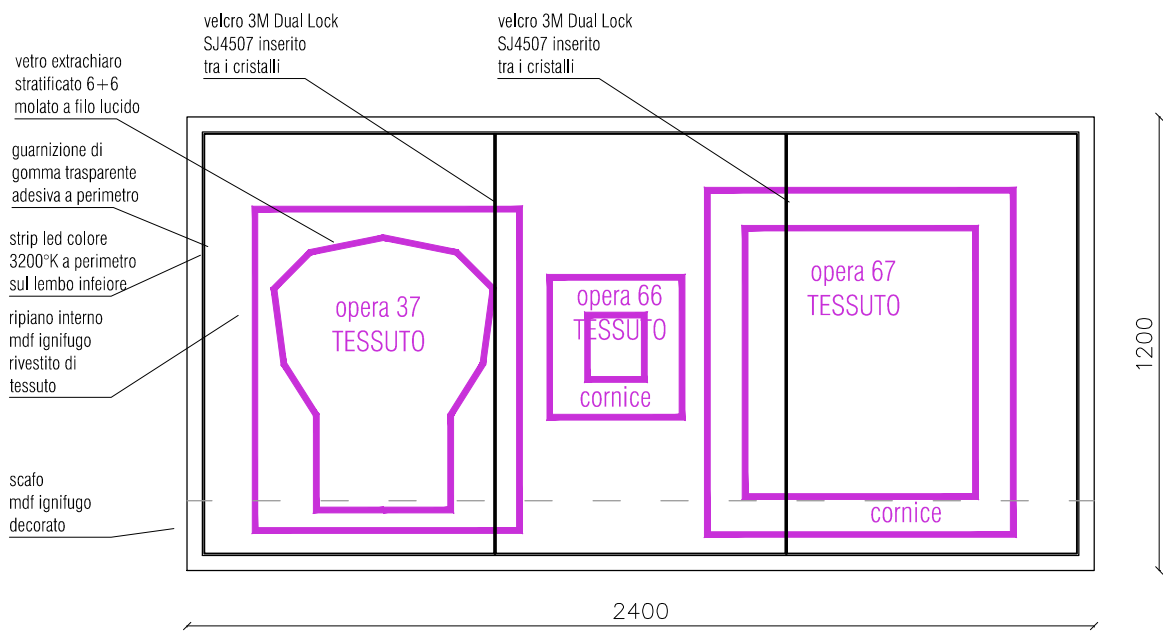

velcro 3M Dual Lock SJ4507 inserito tra i cristalli

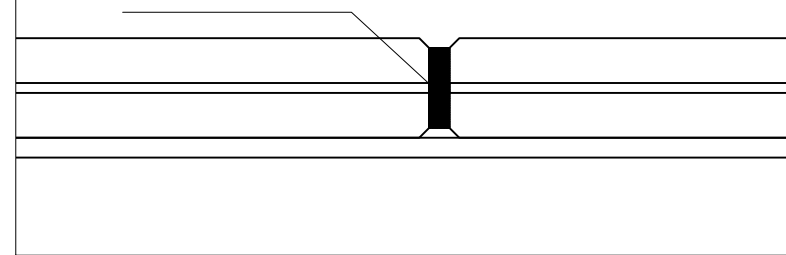

vetro extrachiaro stratificato 6+6 molato a filo lucido

guarnizione di gomma trasparente adesiva a perimetro

strip led colore 3200°K a perimetro sul lembo inferiore

ripiano interno mdf ignifugo rivestito di tessuto

sportello apribile per inserimento art sorb

scafo mdf ignifugo decorato

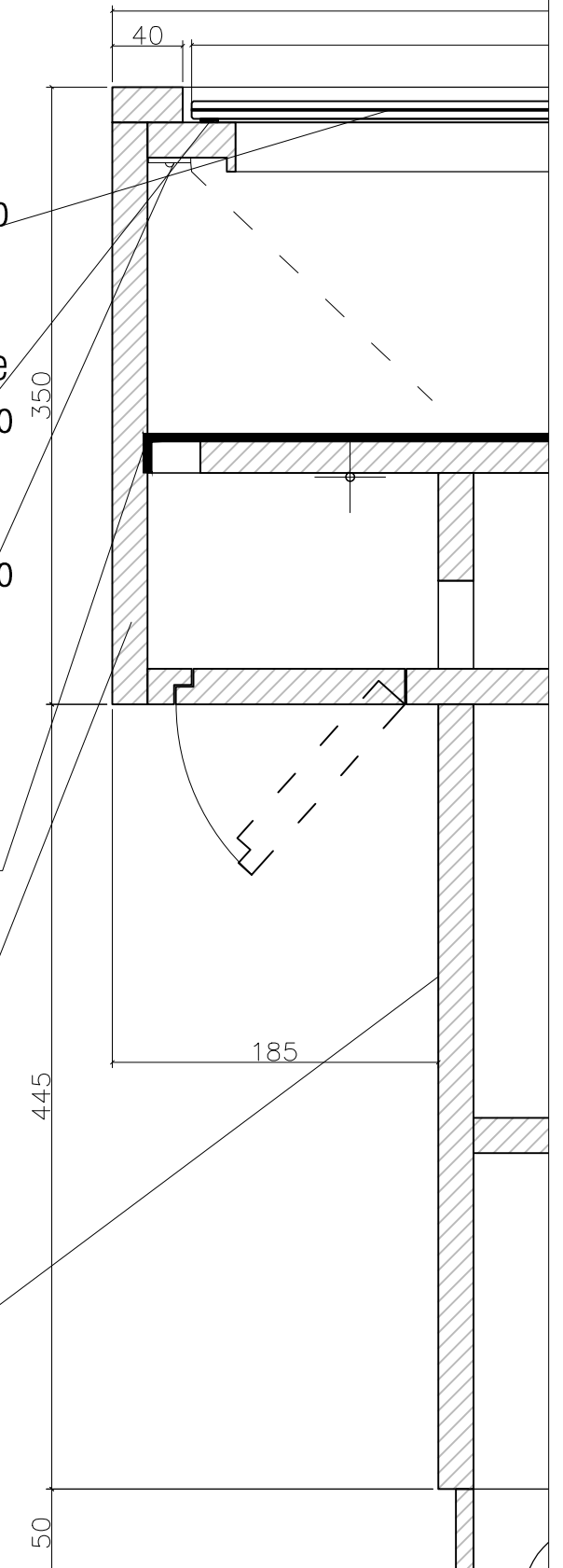

9.02.02 vetrina - nuova fornitura

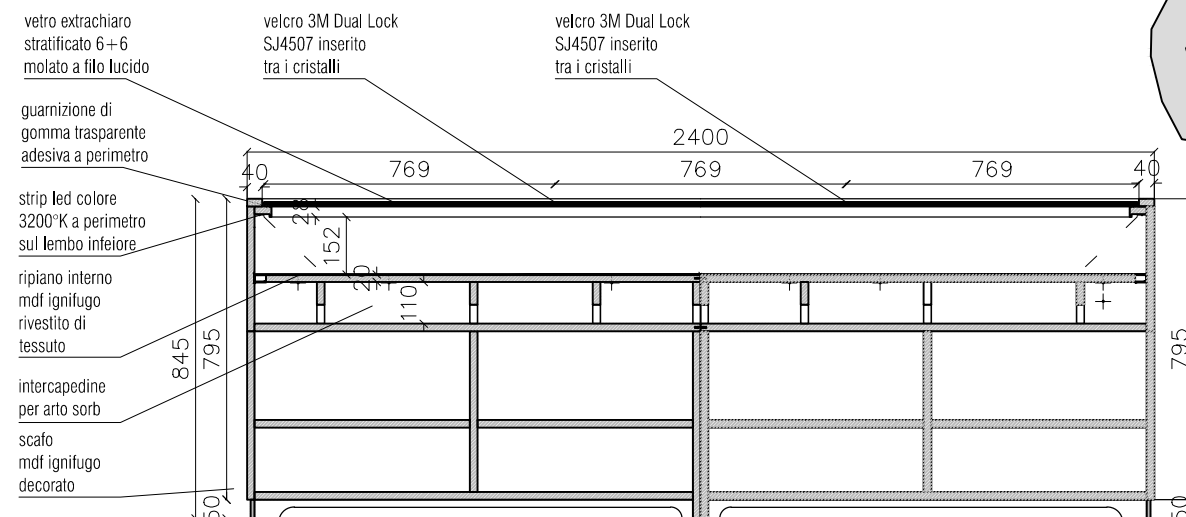

9.02.02 vetrina - nuova fornitura

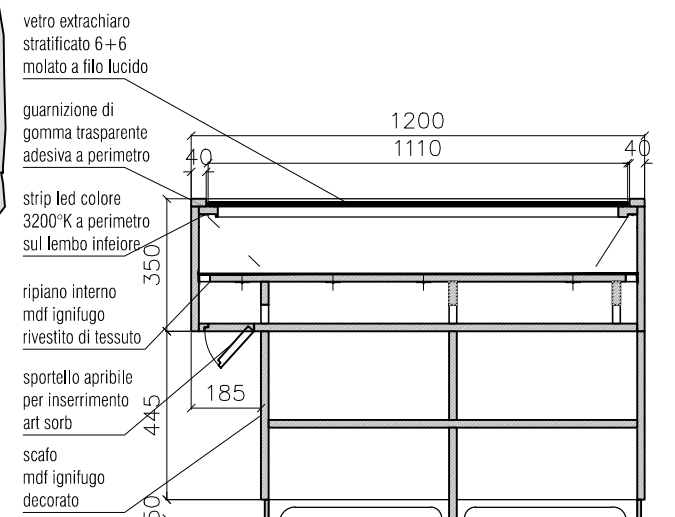

9.02.03 vetrina

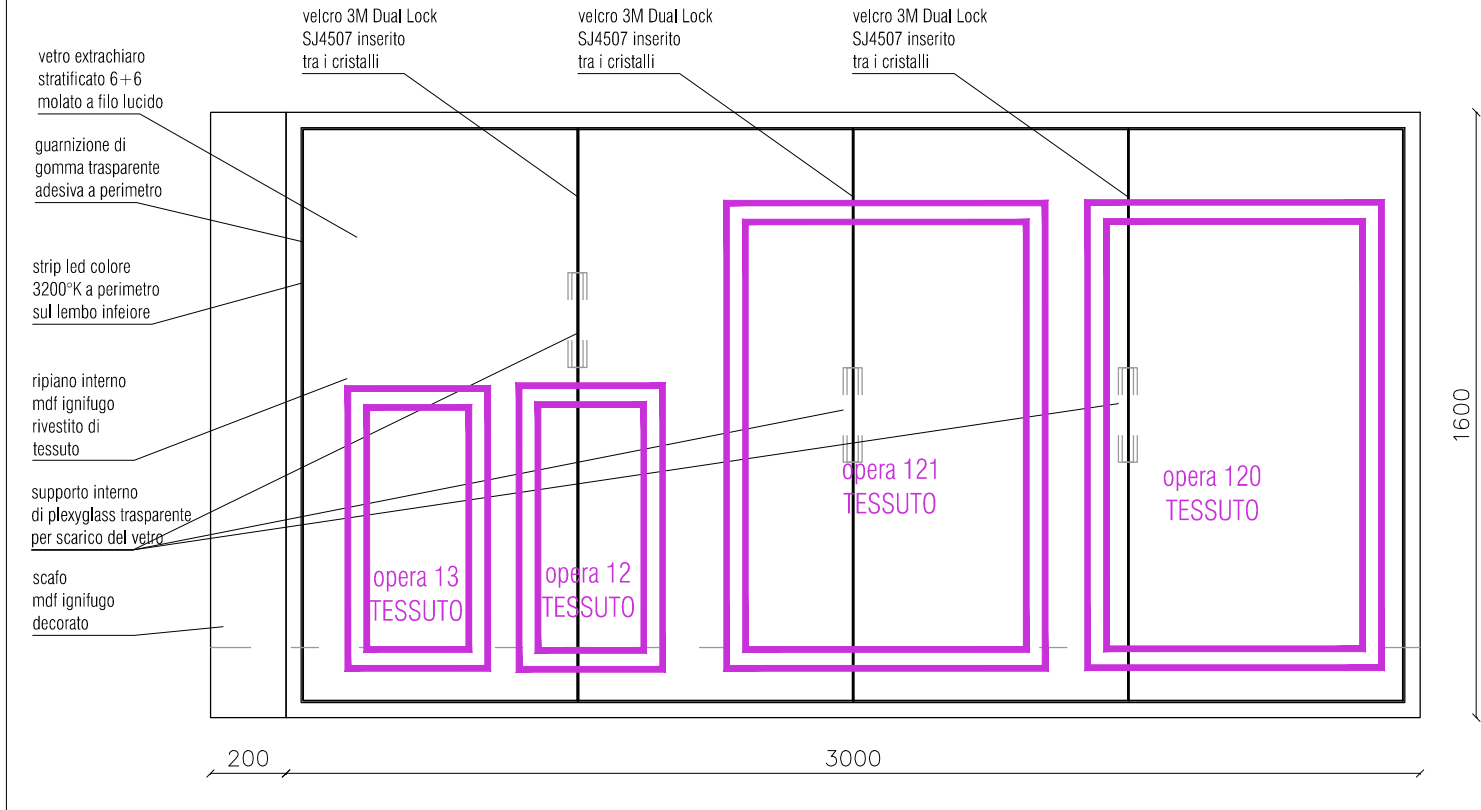

velcro 3M Dual Lock SJ4507 inserito tra i cristalli

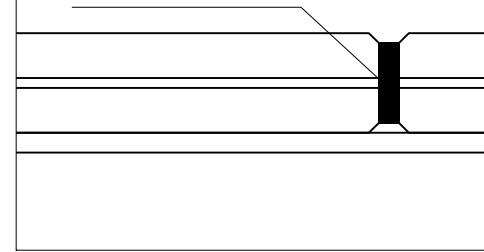

9.02.03 vetrina nuova fornitura

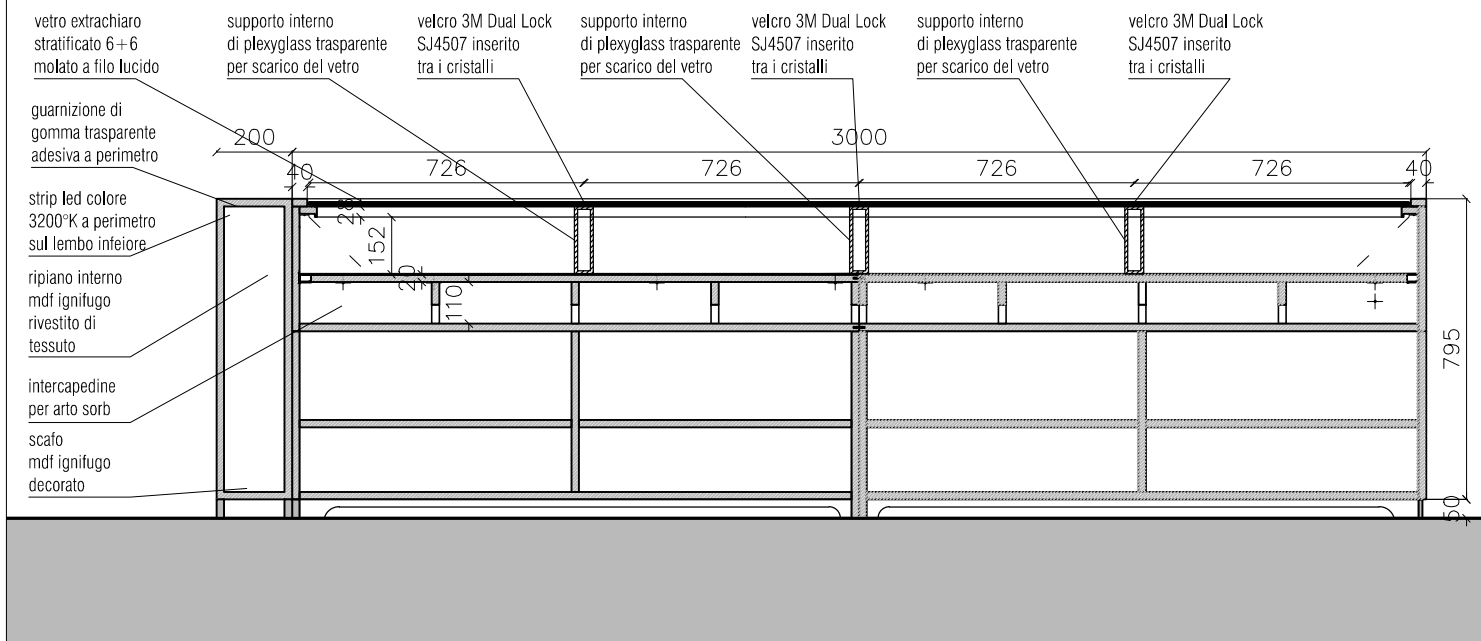

vetro extrachiaro stratificato 6+6 molato a filo lucido

guarnizione di gomma trasparente adesiva a perimetro

strip led colore 3200°K a perimetro sul lembo inferiore

ripiano interno mdf ignifugo rivestito di tessuto

sportello apribile per inserimento art sorb

scafo mdf ignifugo decorato

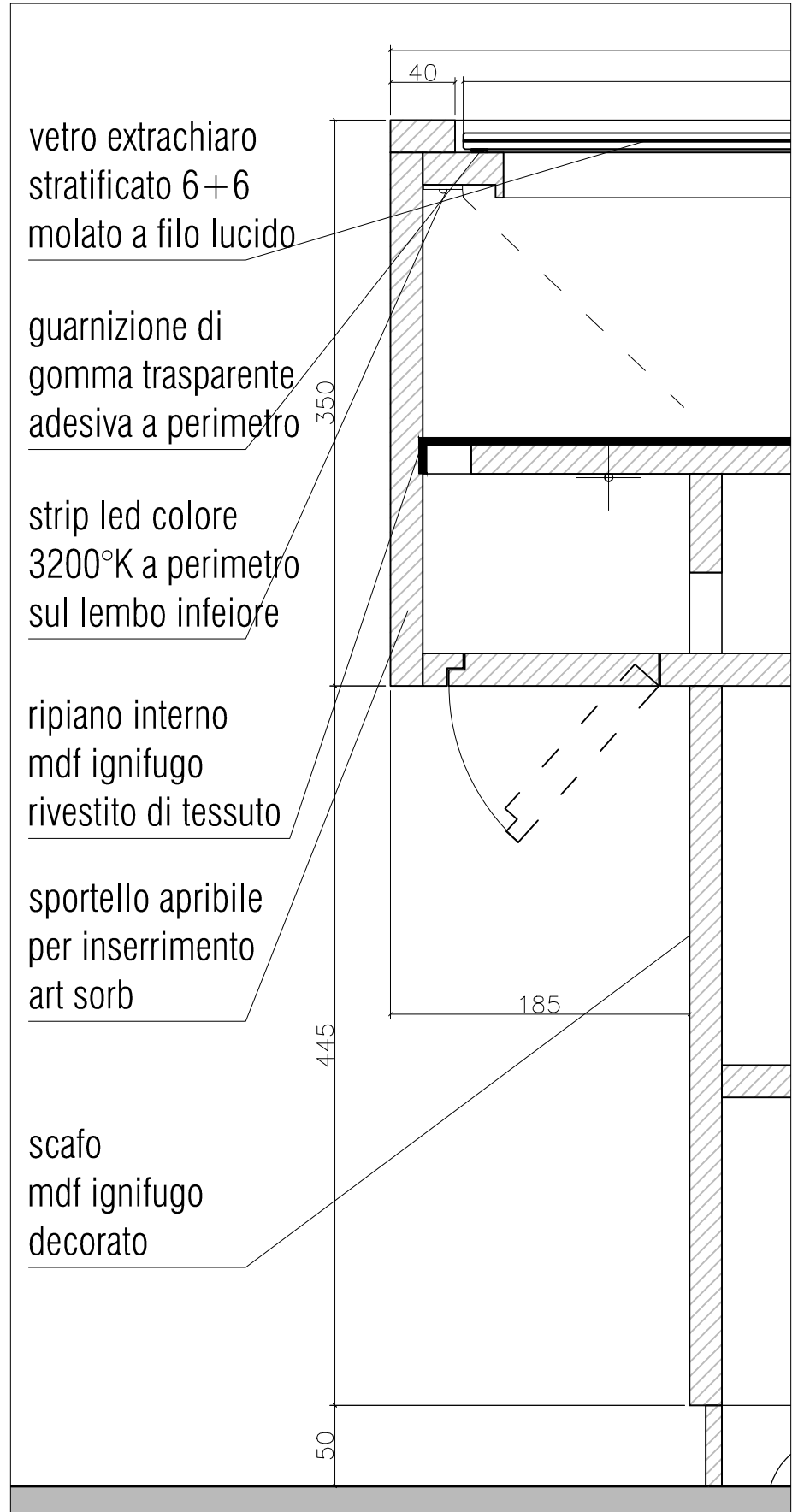

9.02.01 molo+vetrina

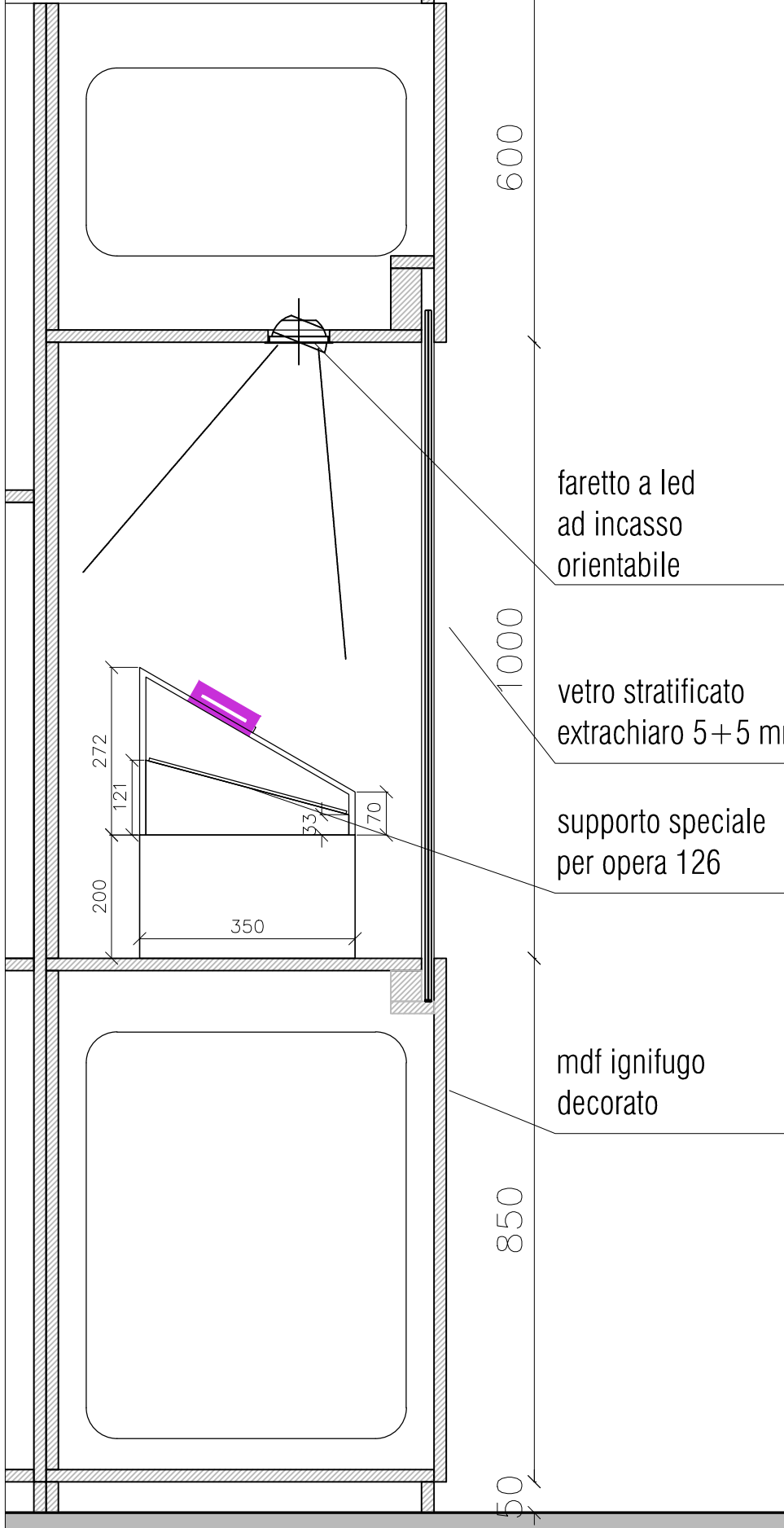

supporto speciale per opera 126

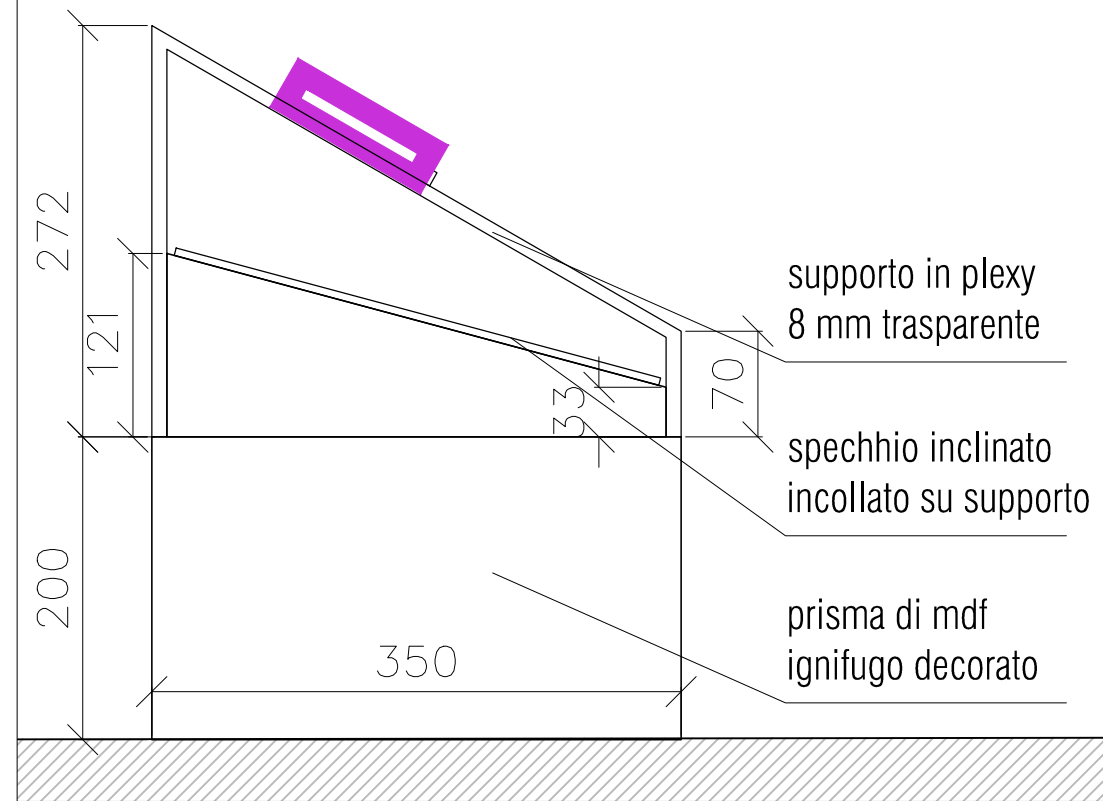

9.02.04 molo+vetrina

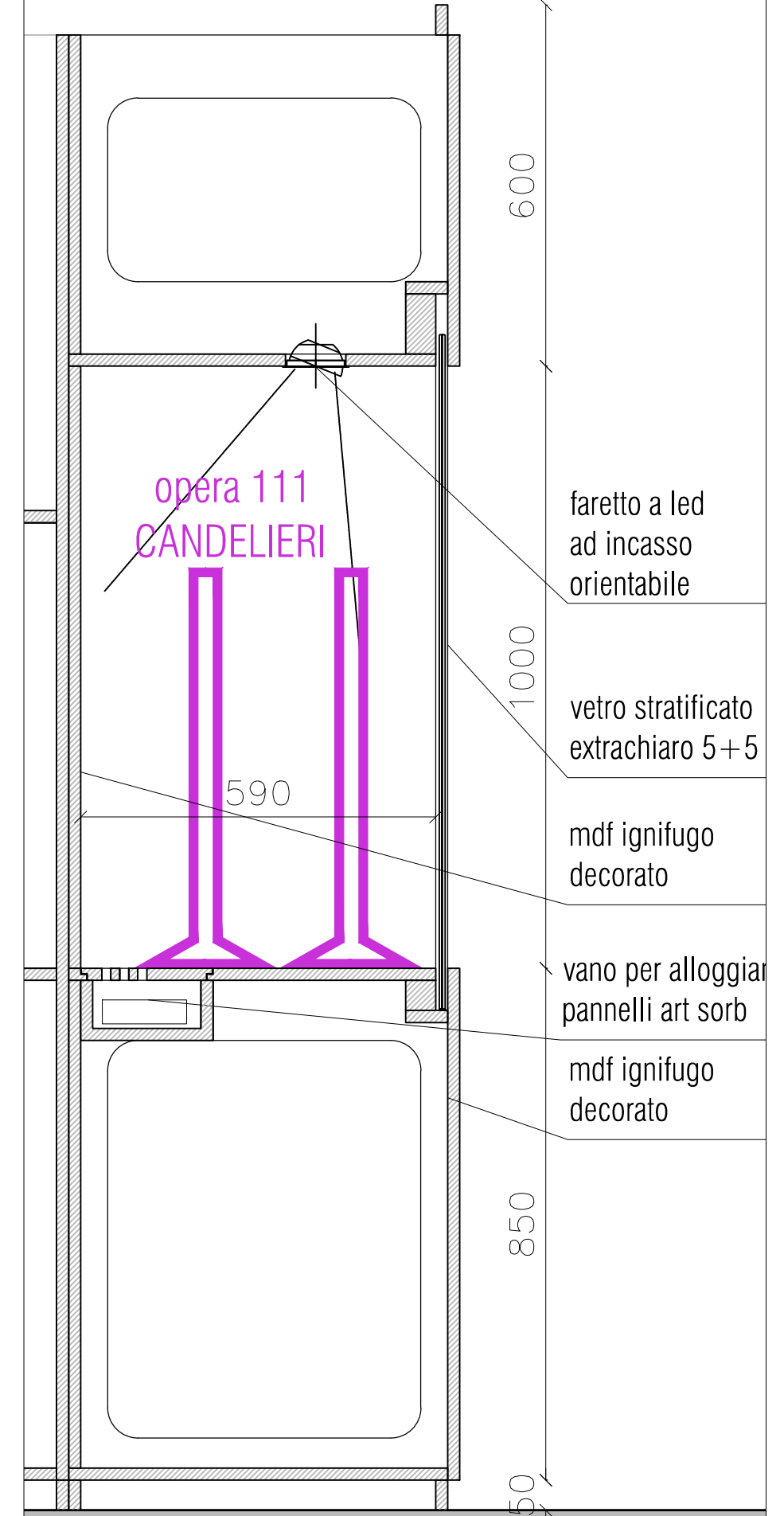



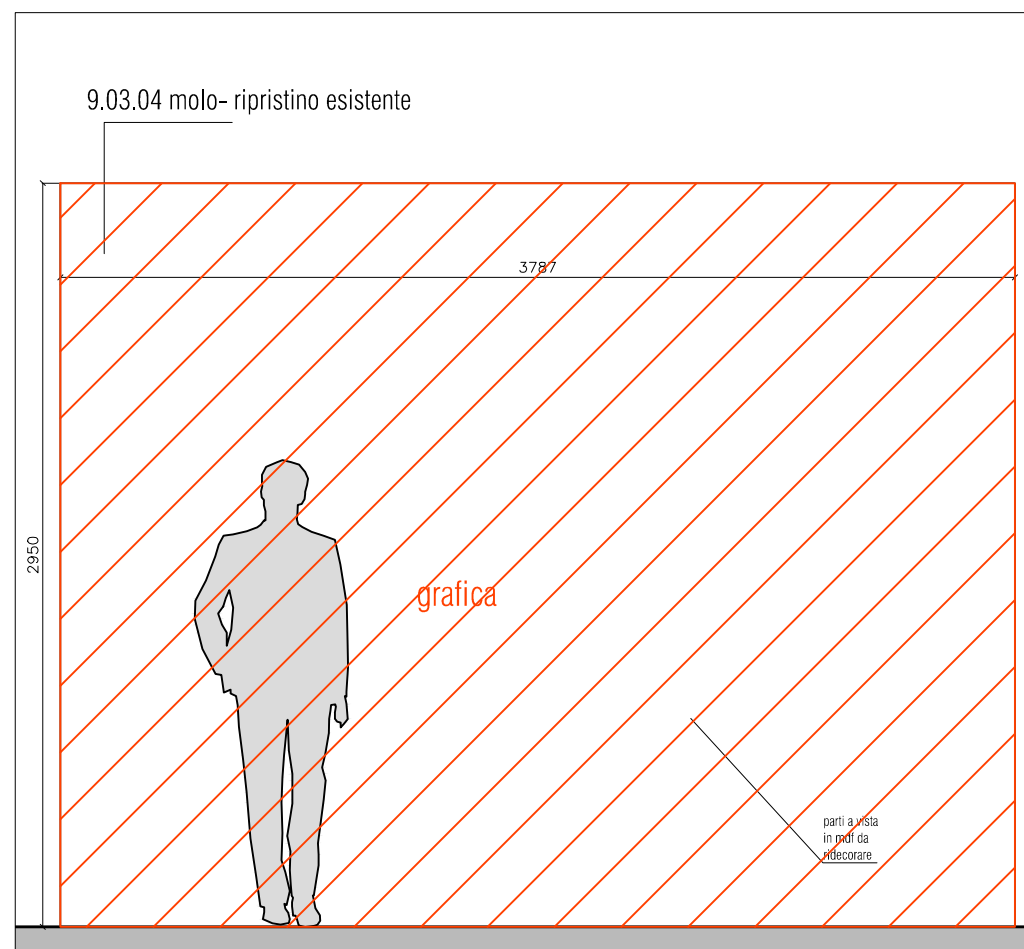
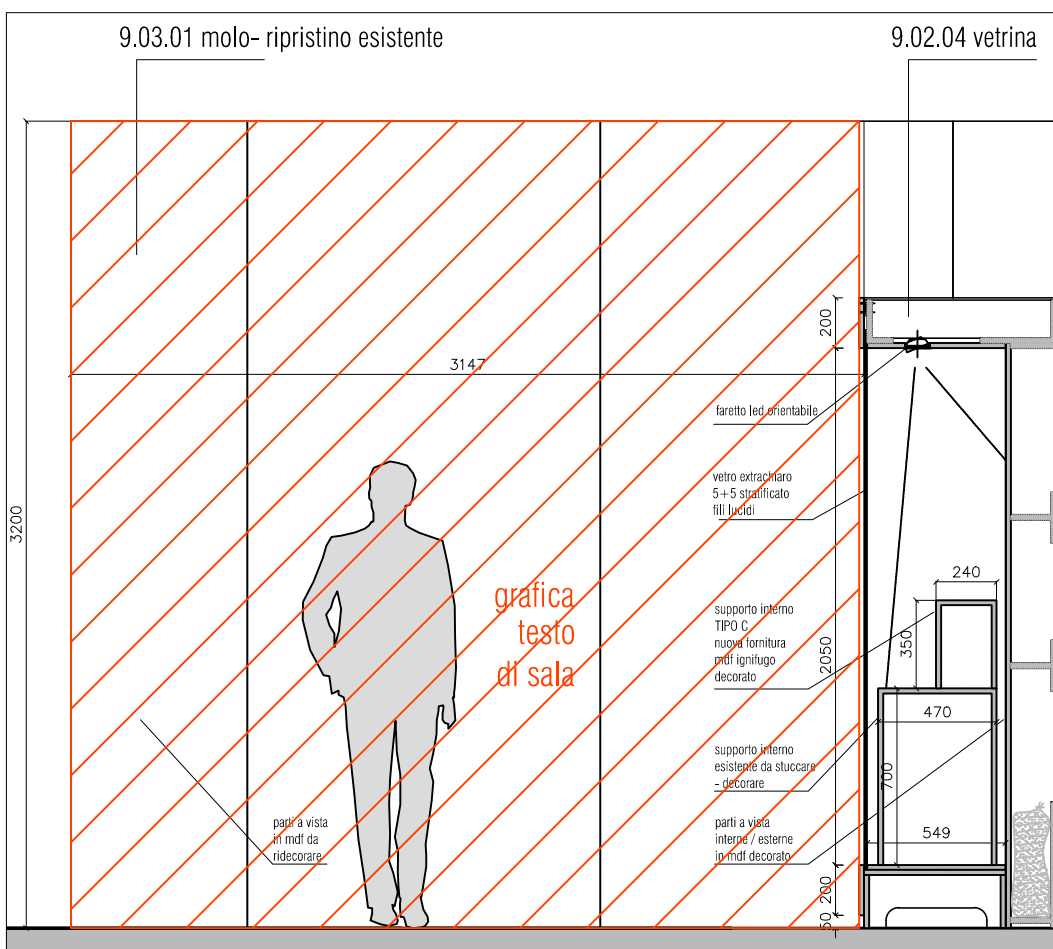
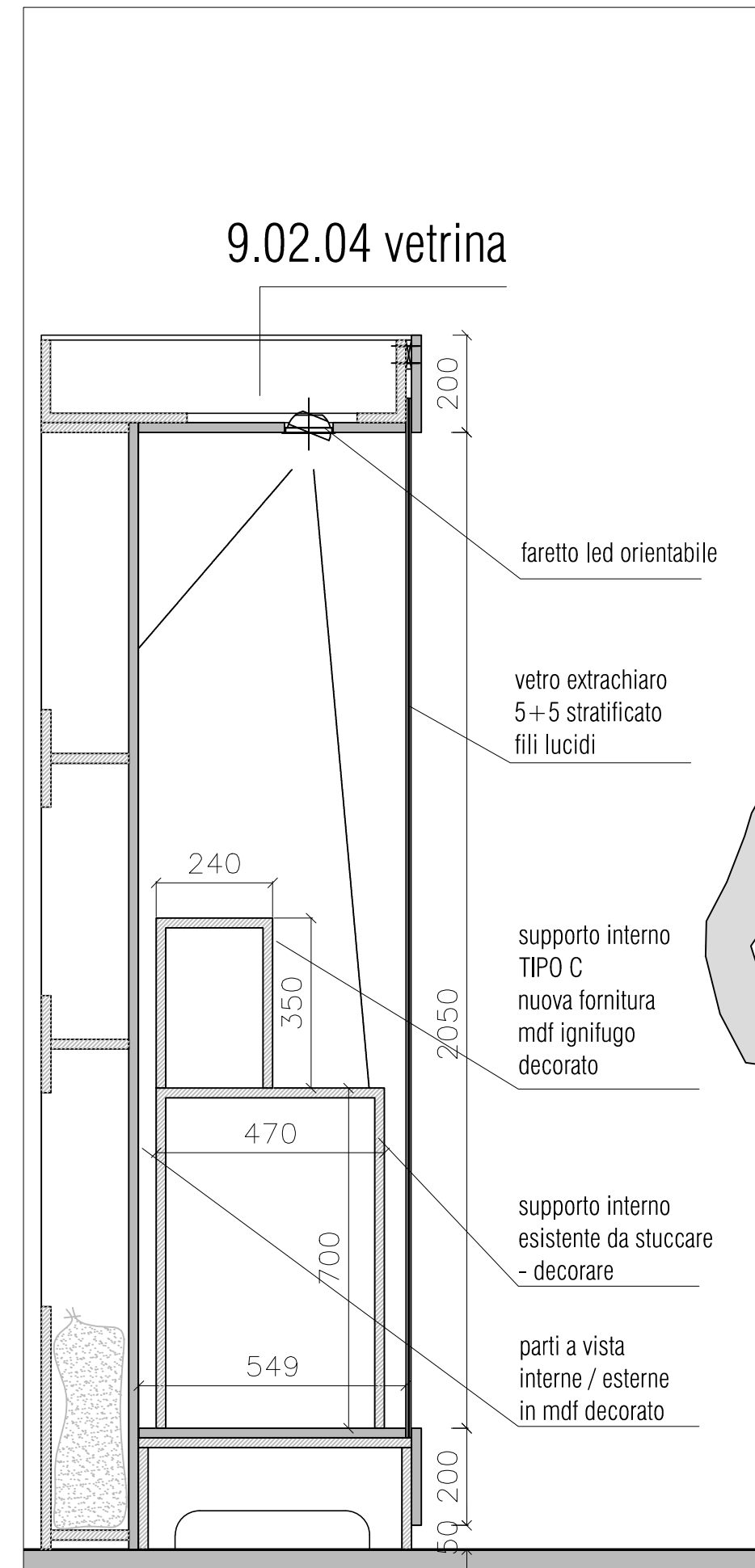
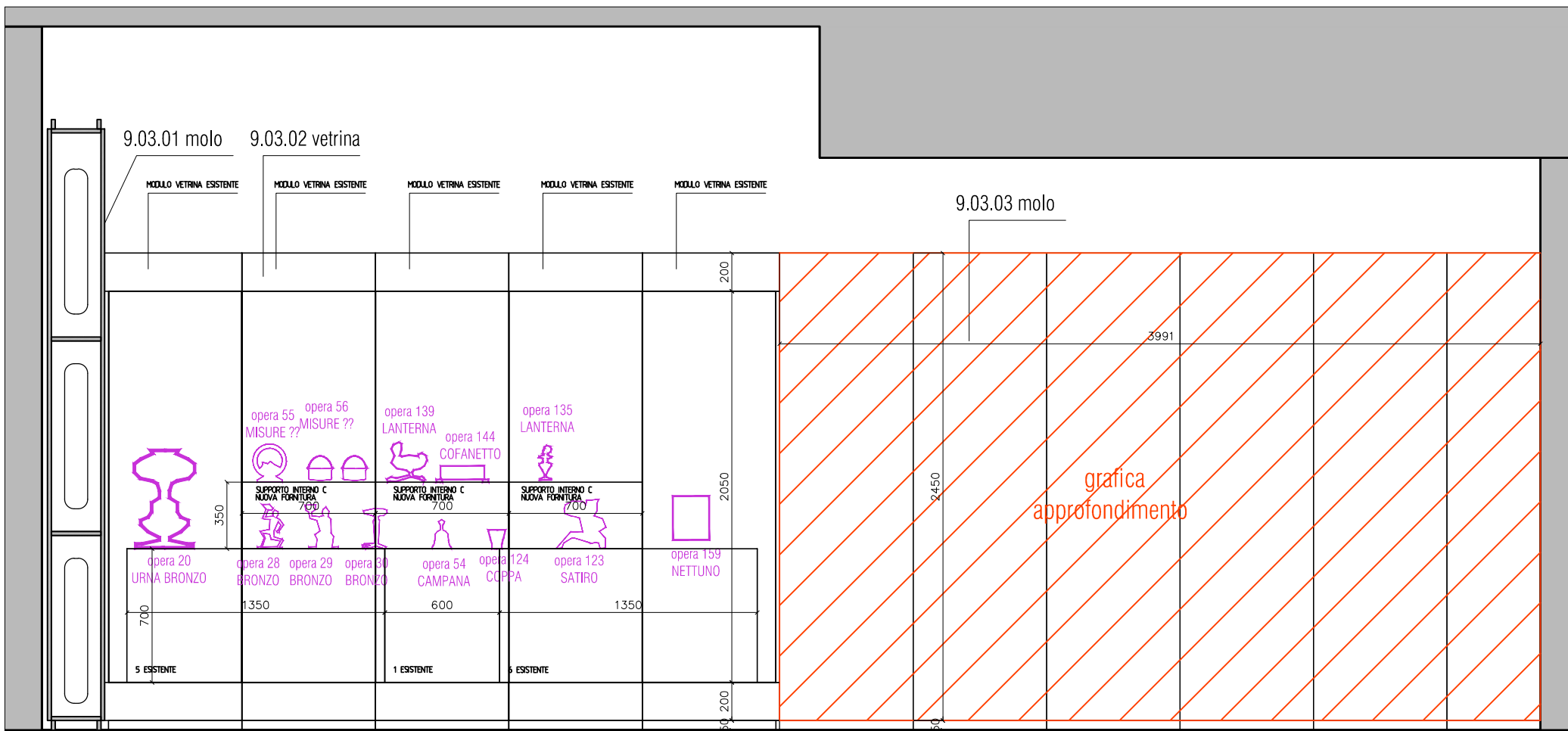

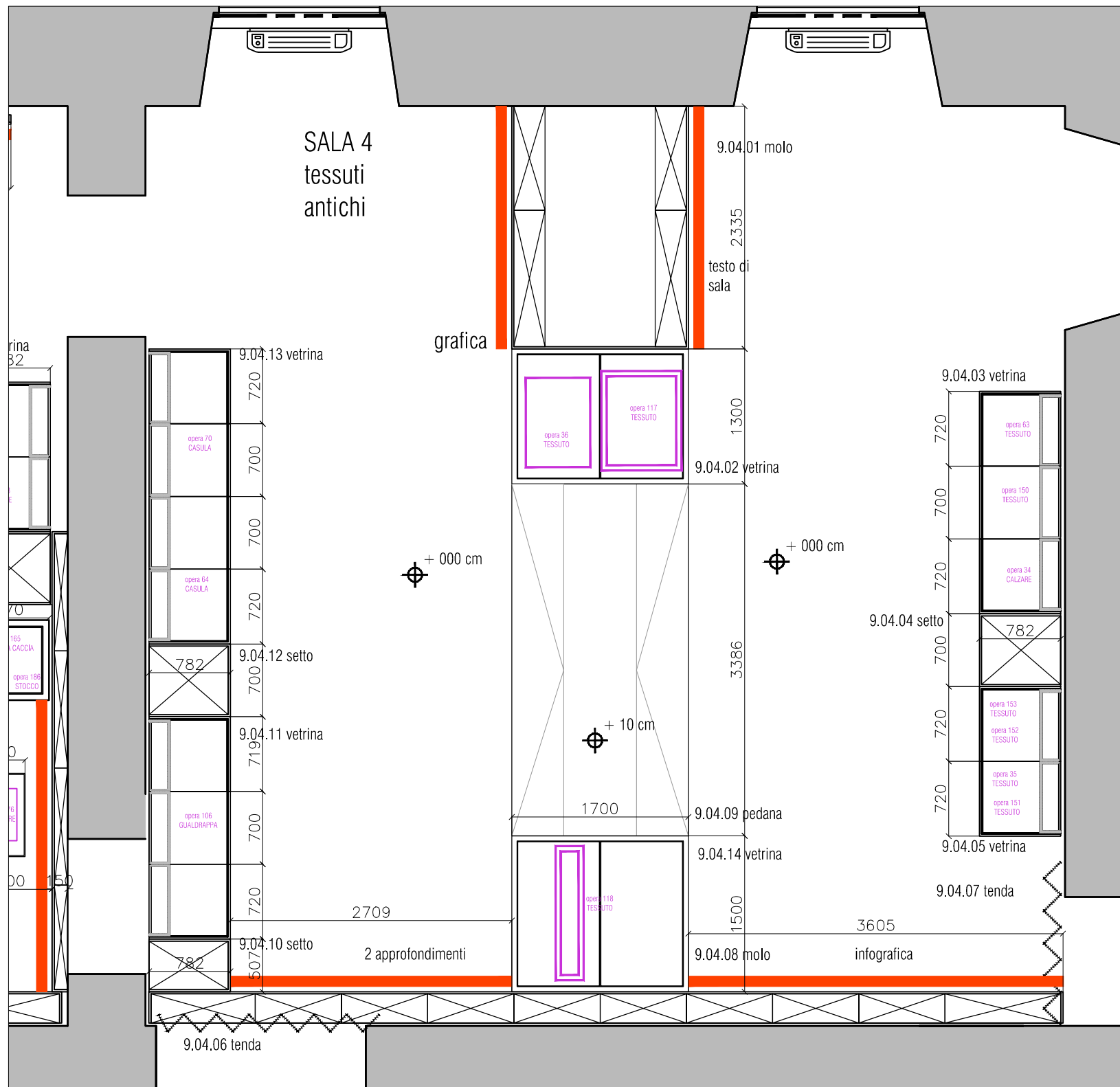

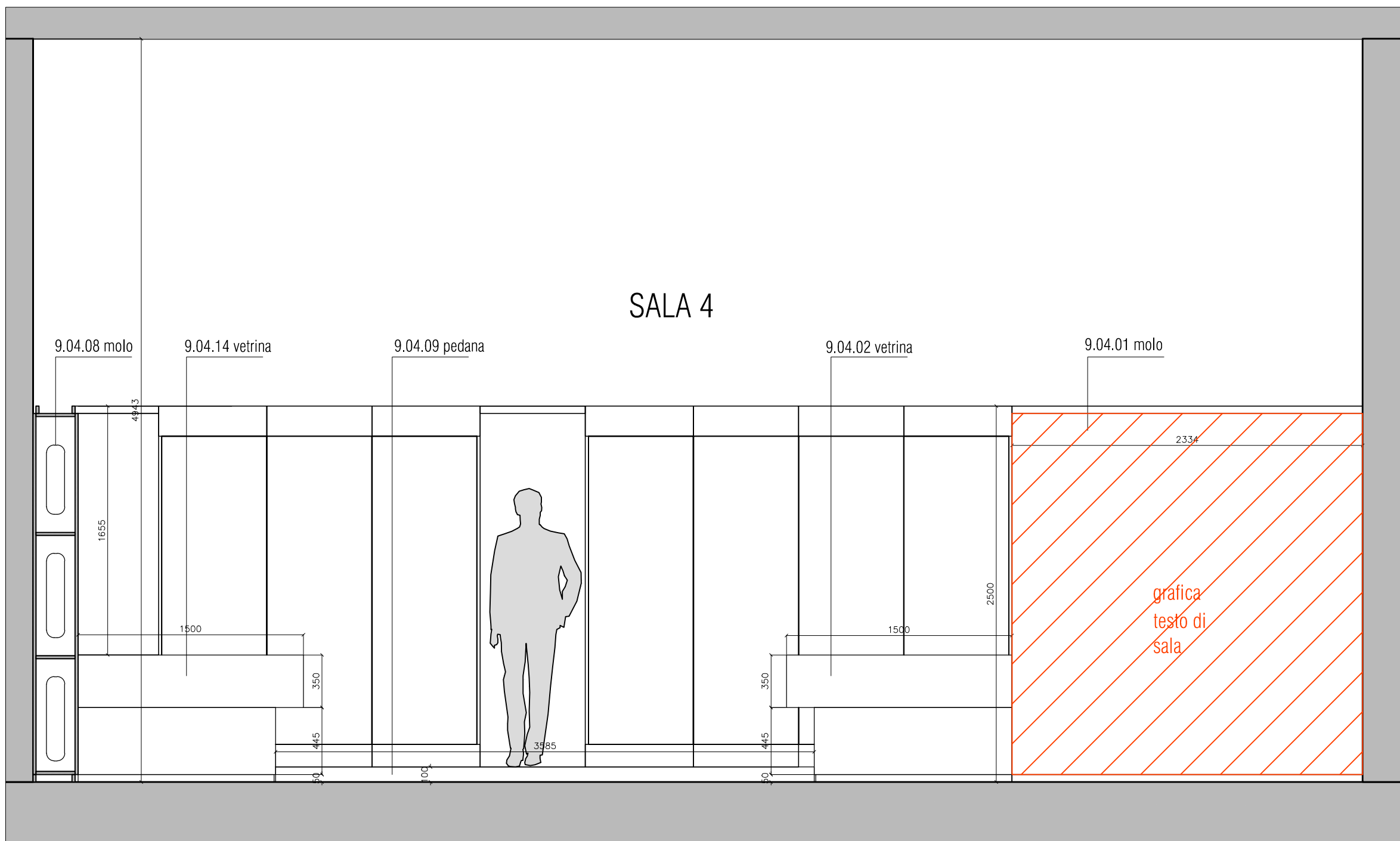

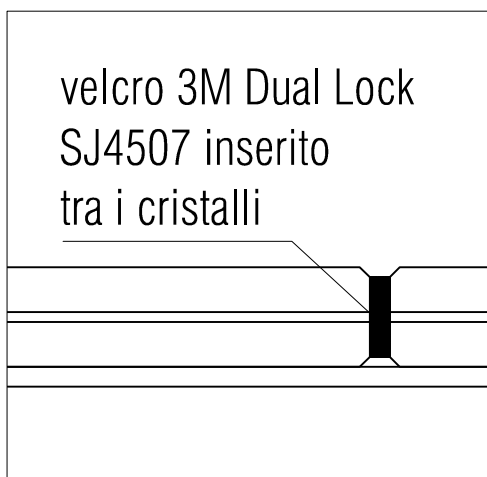
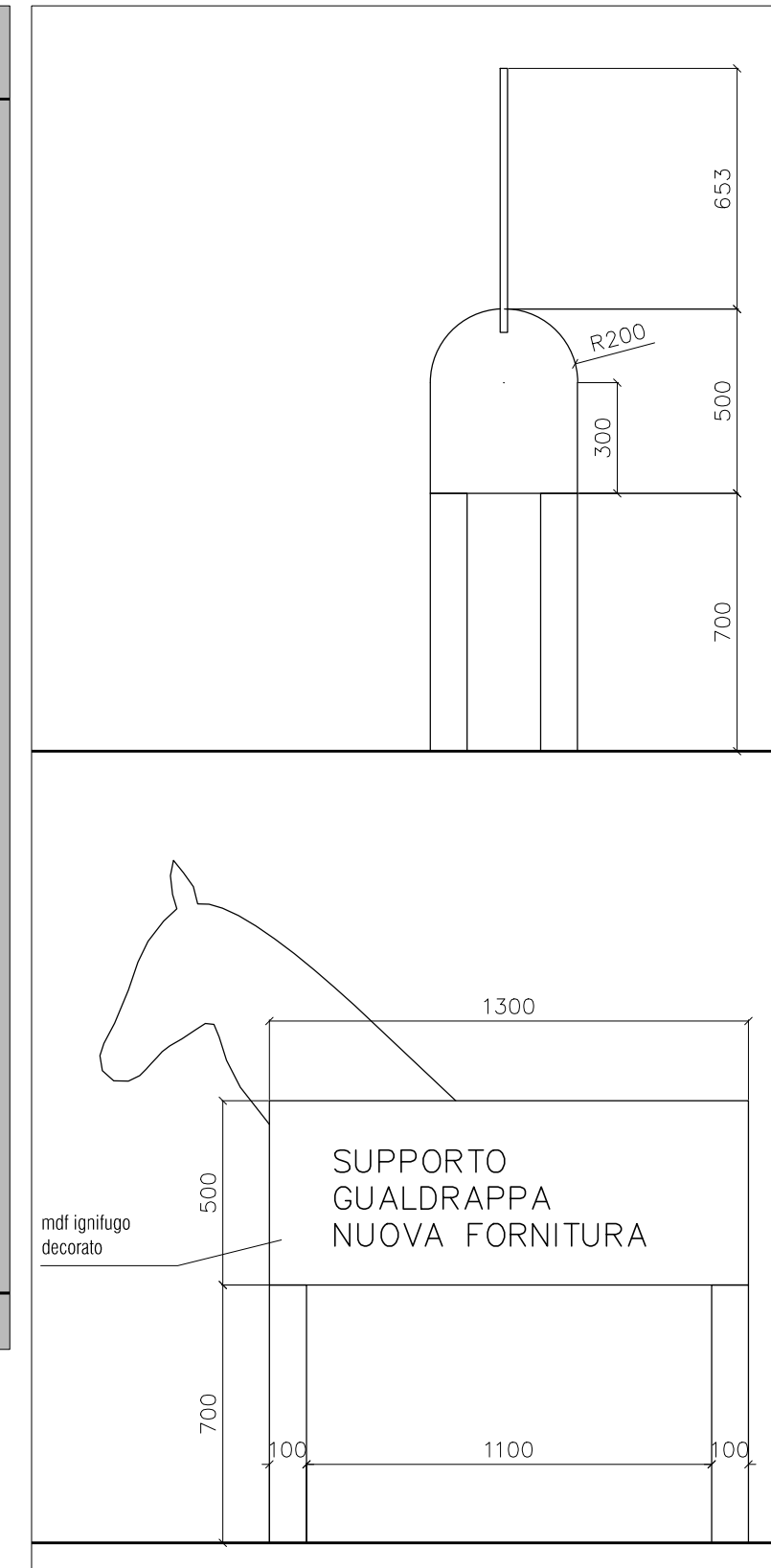
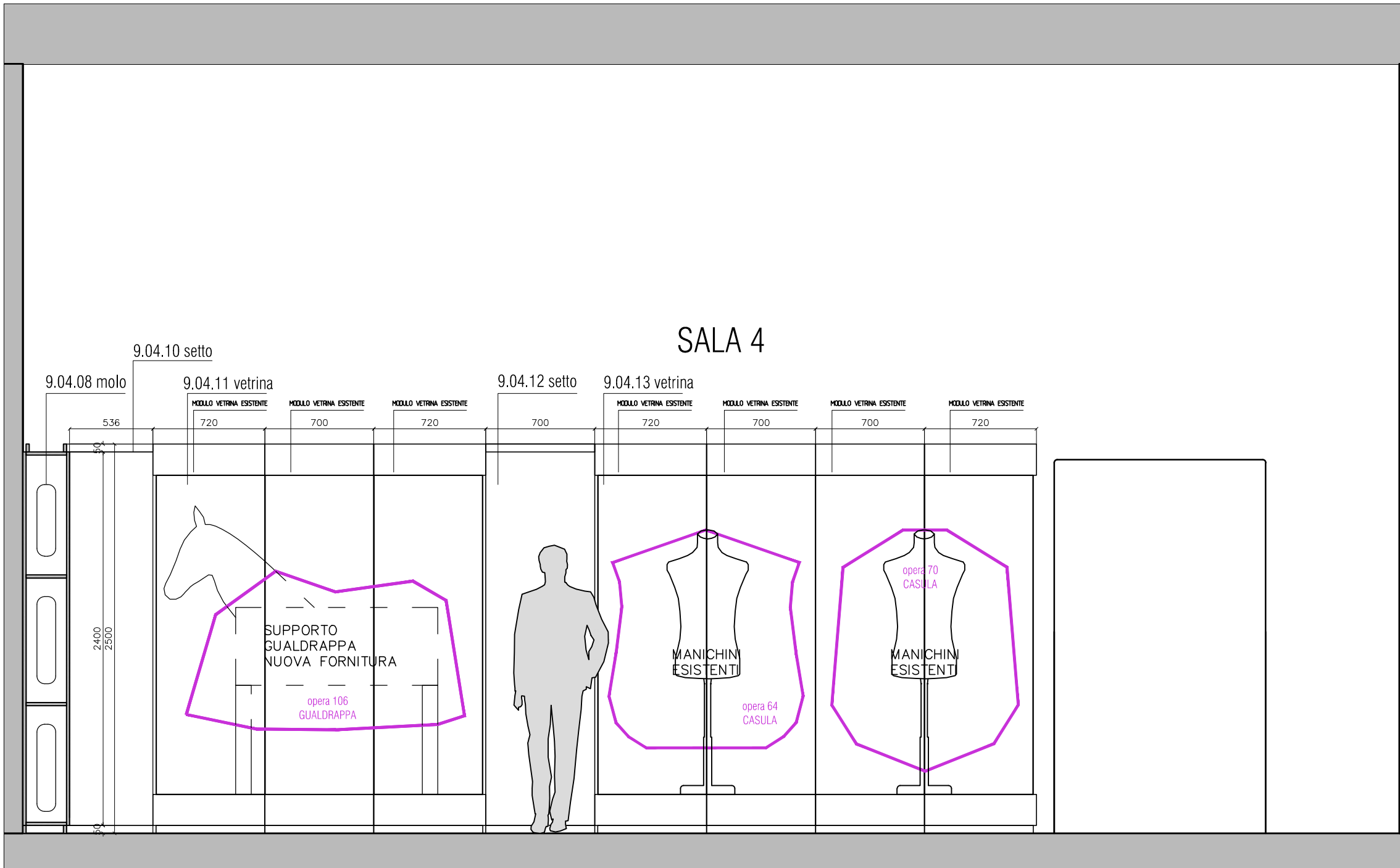

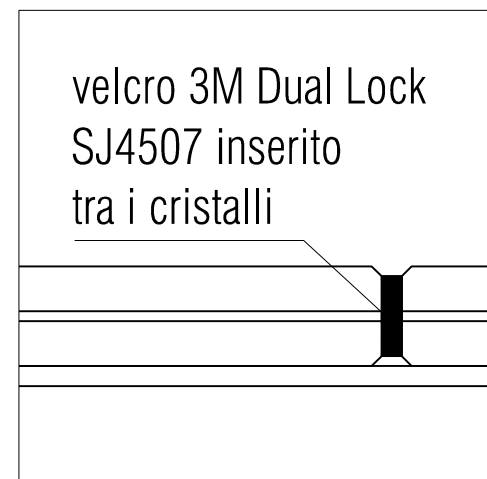
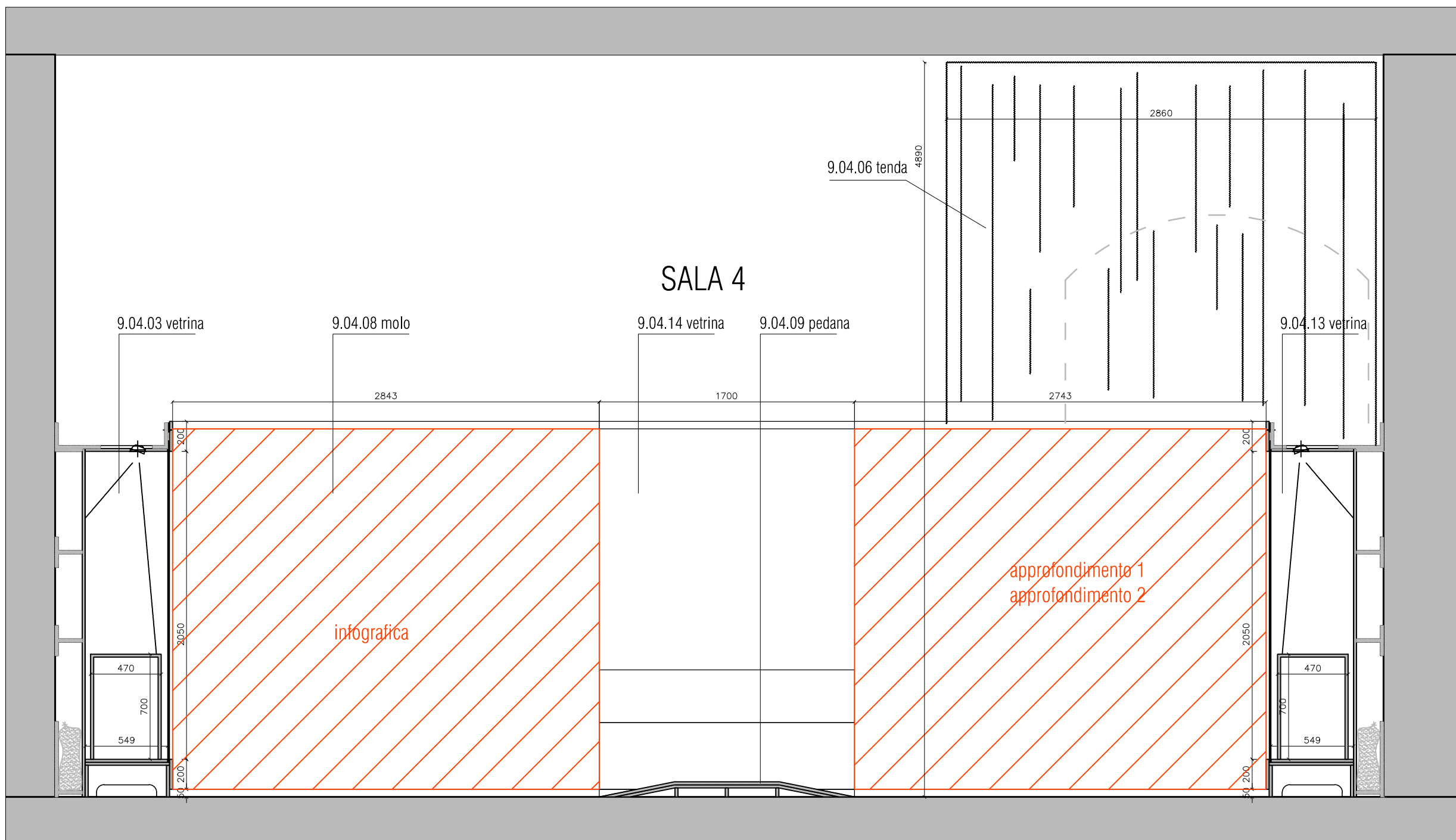

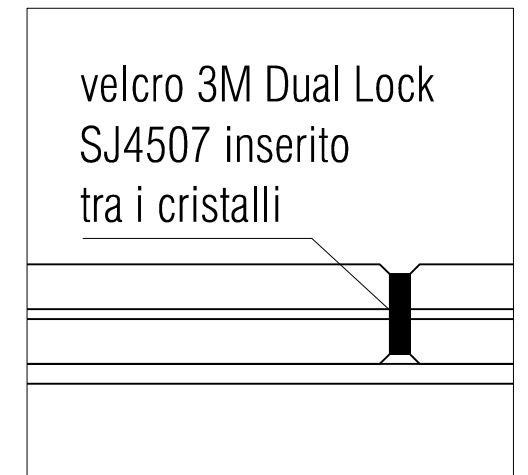
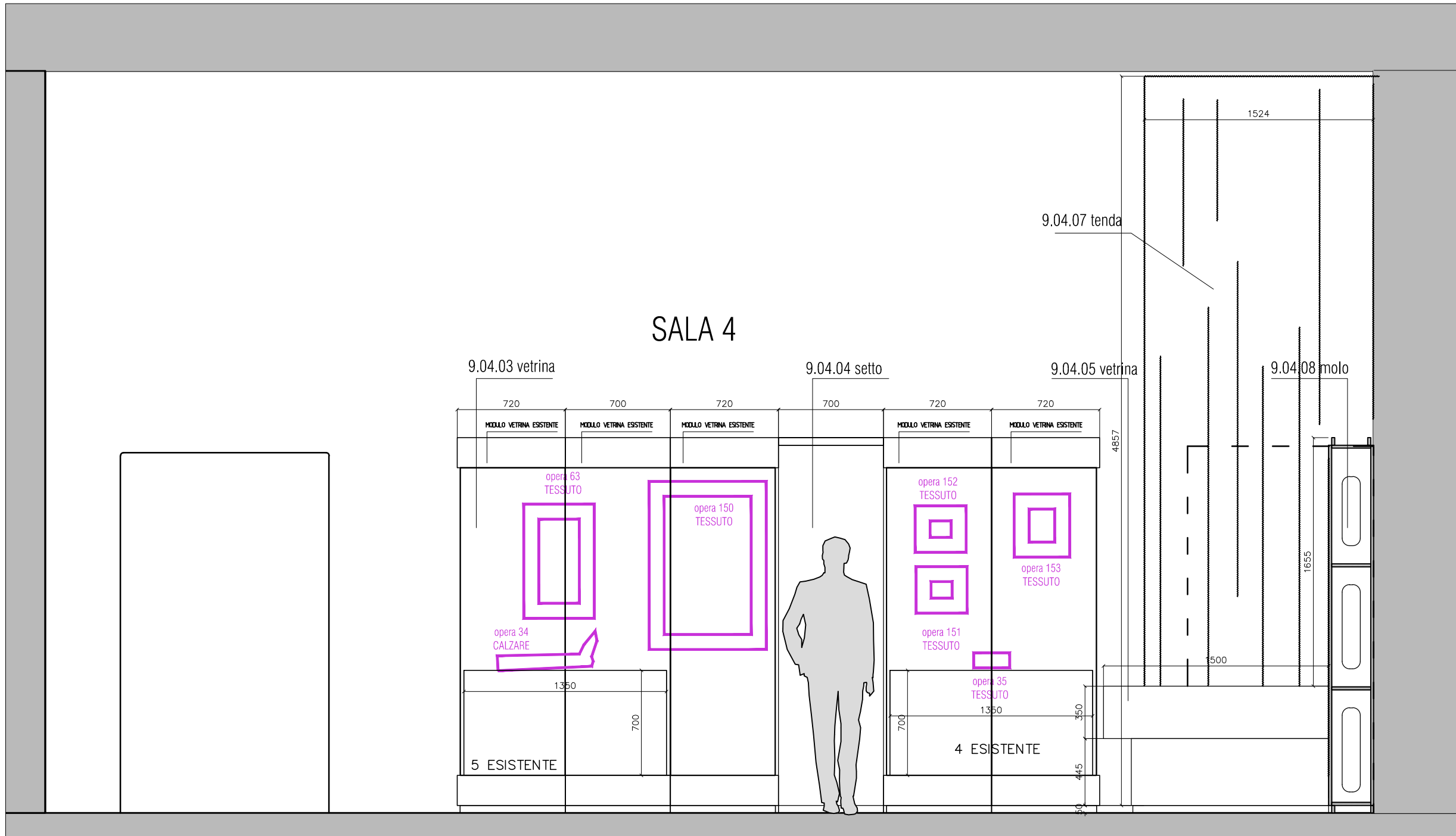

9.04.02 vetrina - nuova fornitura

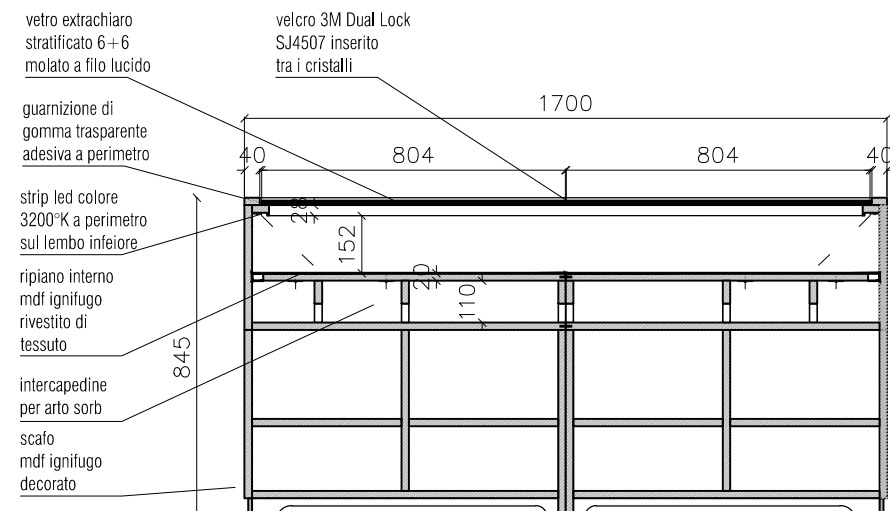

9.04.02 vetrina - nuova fornitura

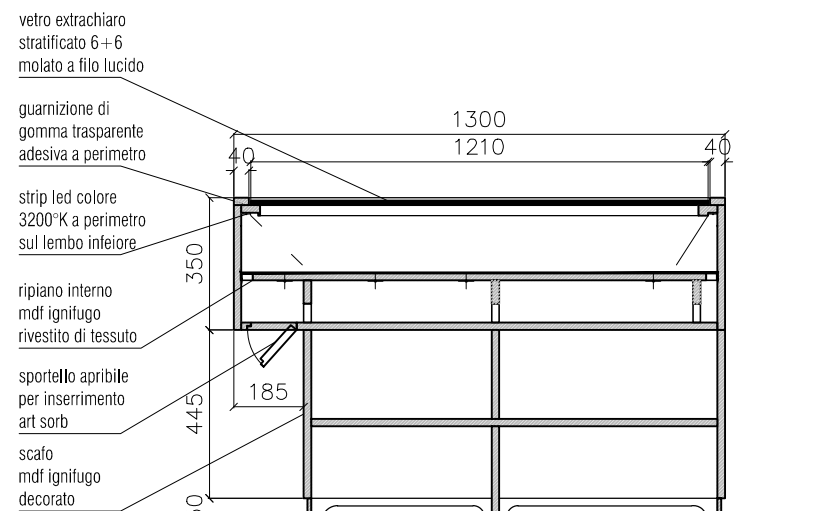

9.04.02 vetrina - nuova fornitura

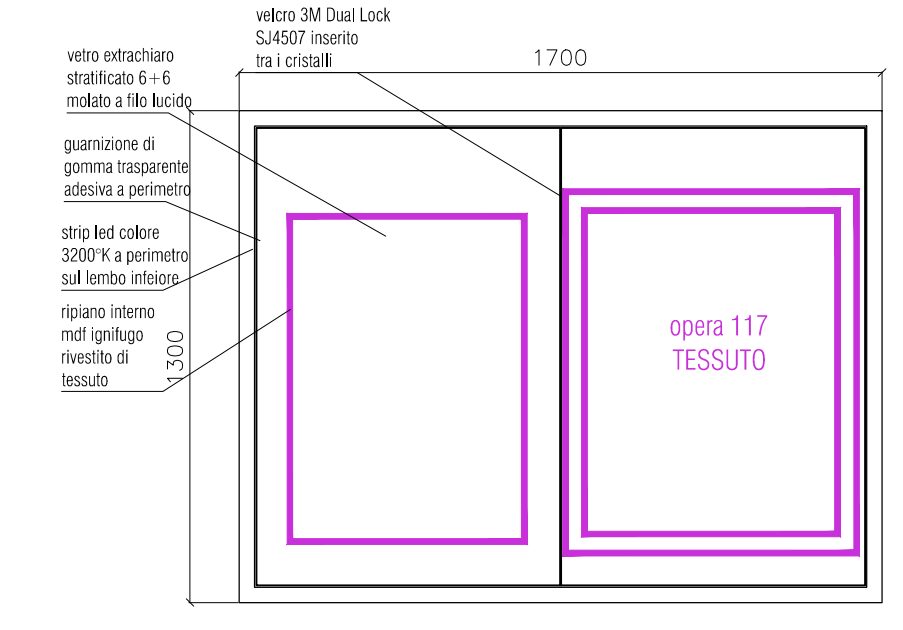

velcro 3M Dual Lock SJ4507 inserito tra i cristalli

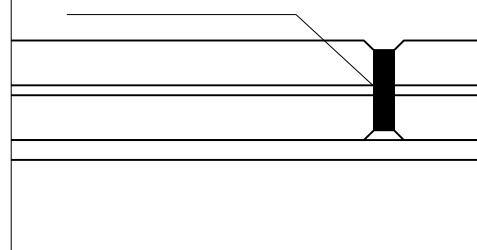

vetro extrachiaro stratificato 6+6 molato a filo lucido

guarnizione di gomma trasparente adesiva a perimetro

strip led colore 3200°K a perimetro sul lembo inferiore

ripiano interno mdf ignifugo rivestito di tessuto

sportello apribile per inserimento art sorb

scafo mdf ignifugo decorato

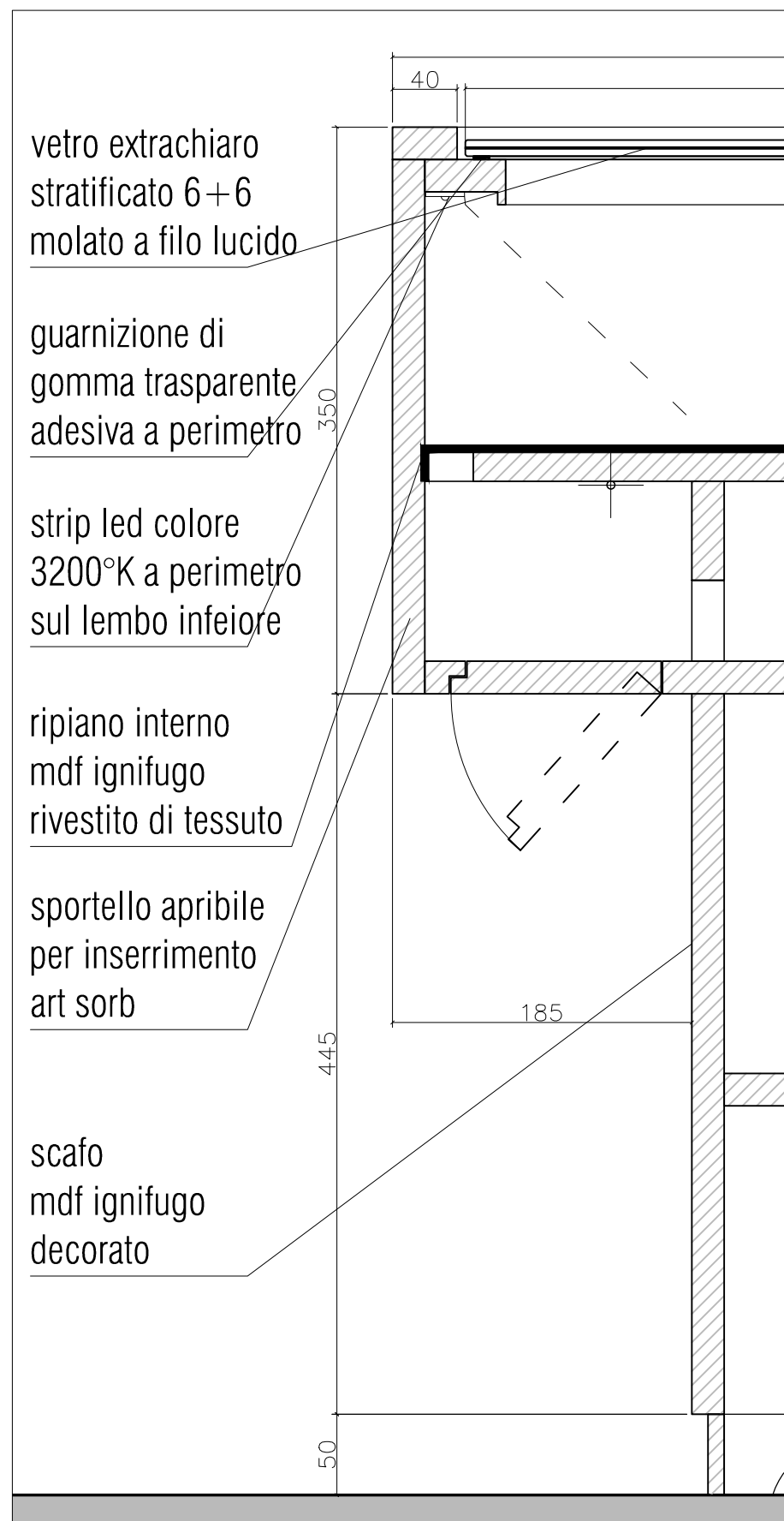

9.04.14 vetrina - nuova fornitura

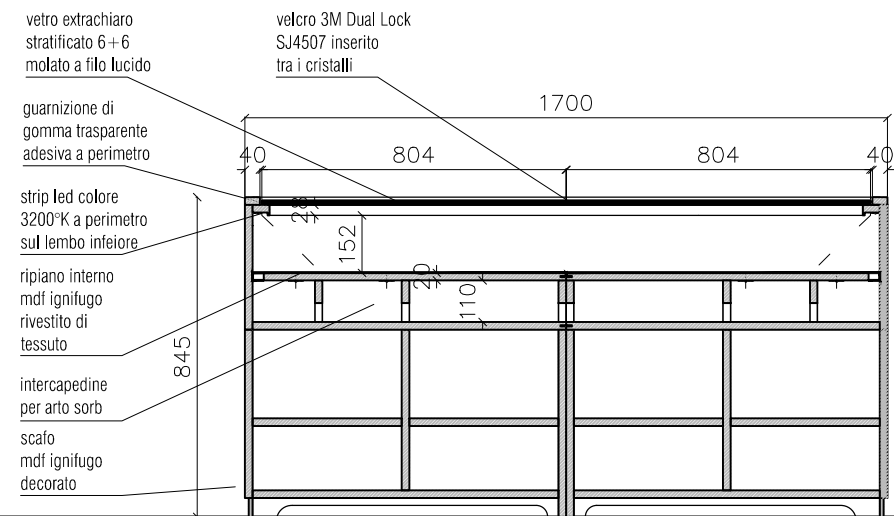

9.04.14 vetrina - nuova fornitura

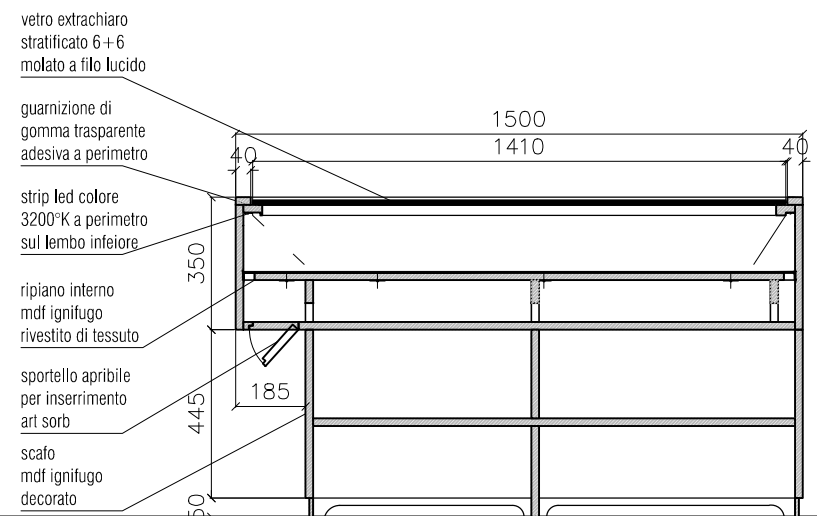

9.04.02 vetrina - nuova fornitura

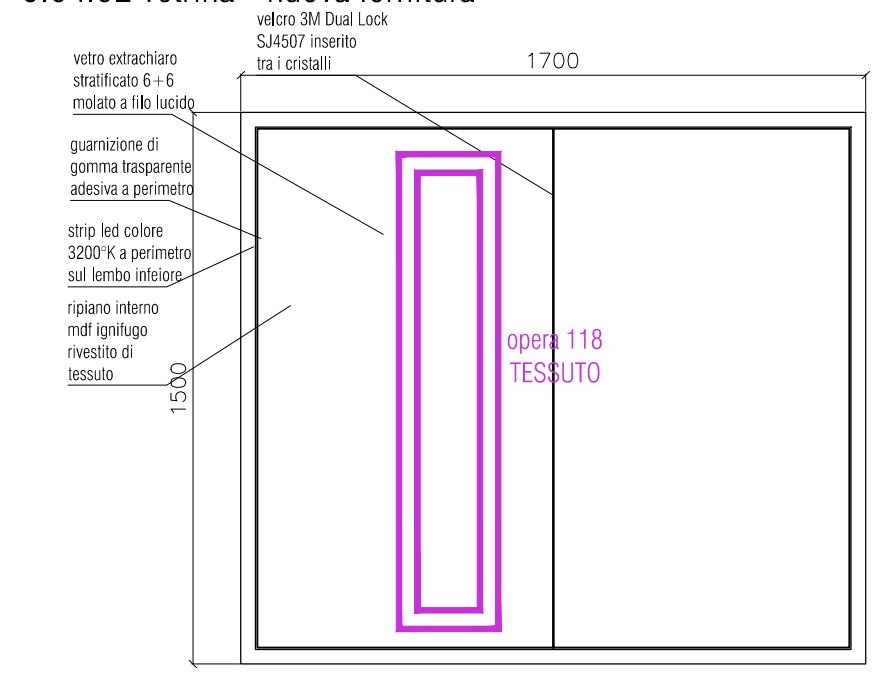

velcro 3M Dual Lock SJ4507 inserito tra i cristalli

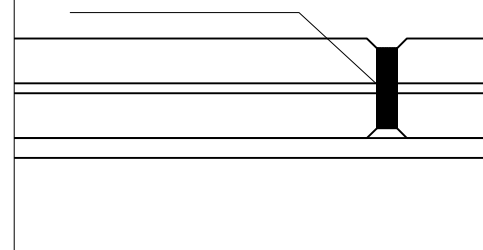

vetro extrachiaro stratificato 6+6 molato a filo lucido

guarnizione di gomma trasparente adesiva a perimetro

strip led colore 3200°K a perimetro sul lembo inferiore

ripiano interno mdf ignifugo rivestito di tessuto

sportello apribile per inserimento art sorb

scafo mdf ignifugo decorato

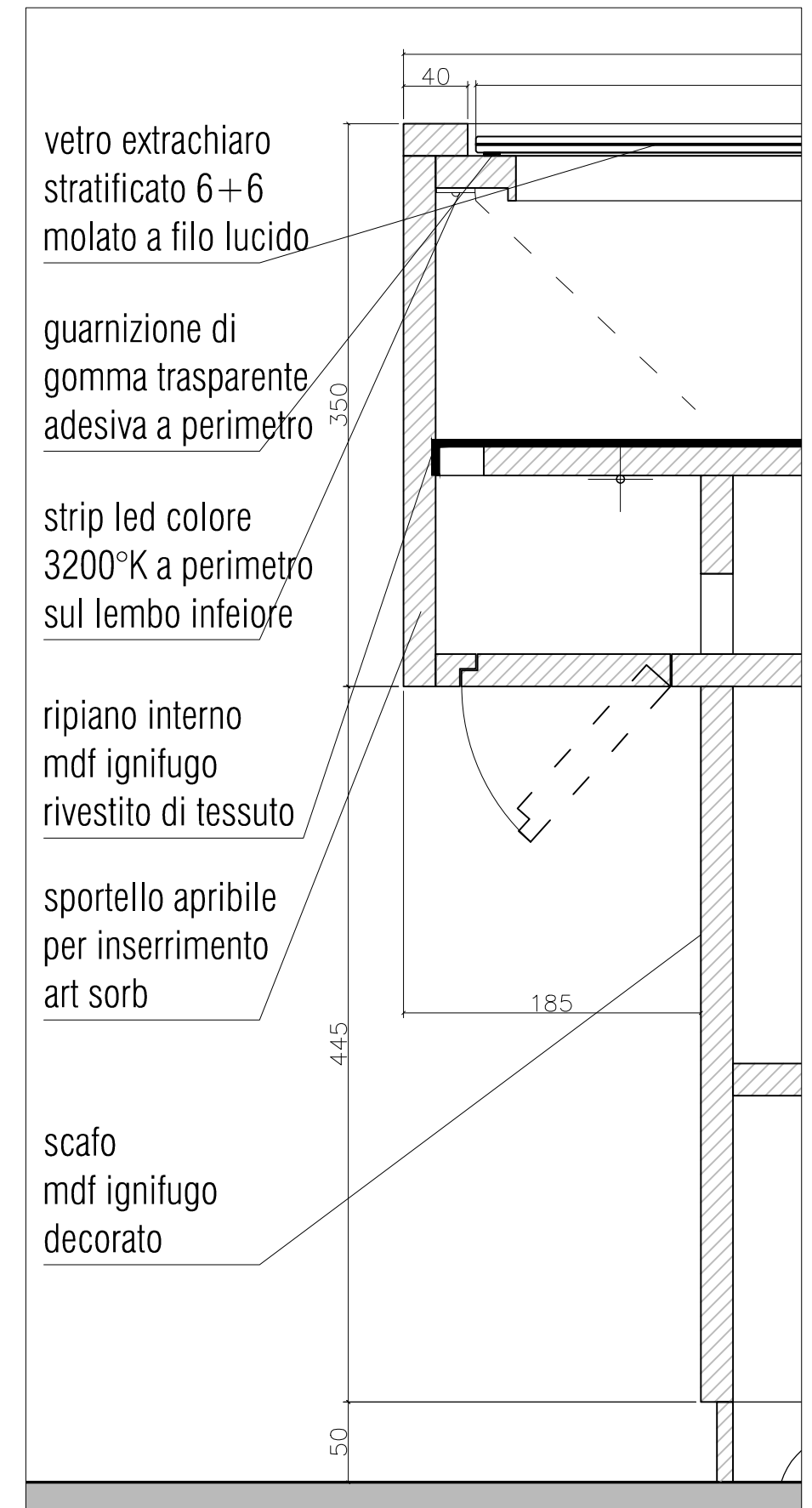



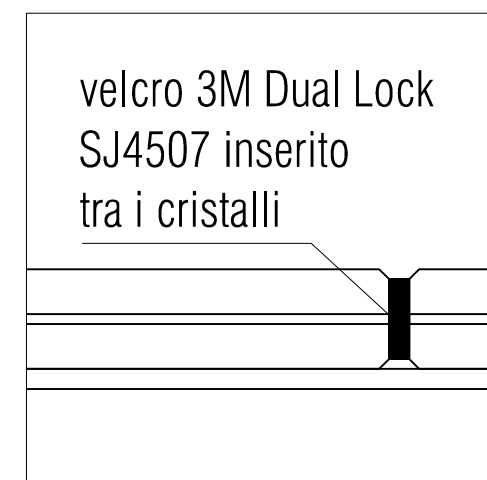
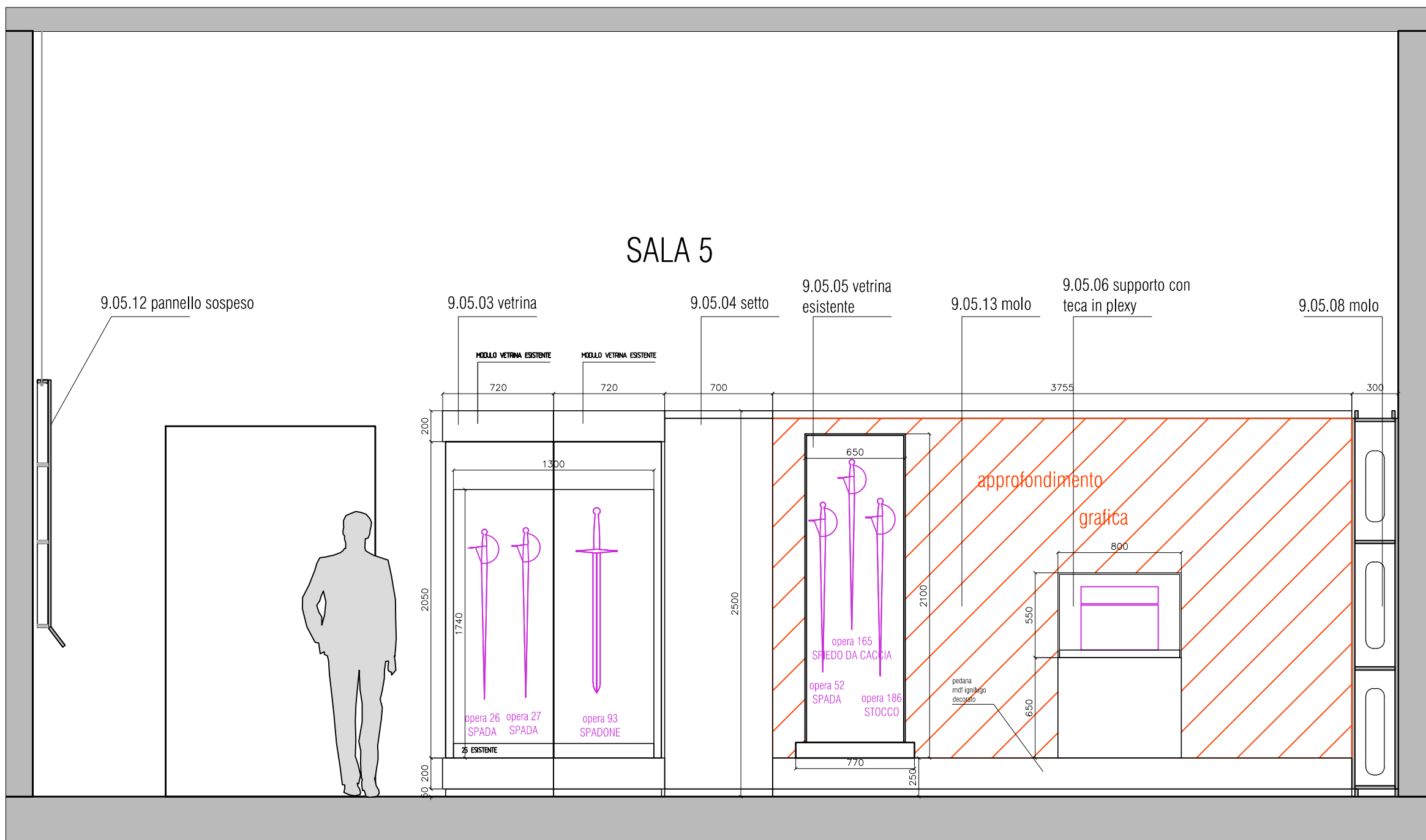

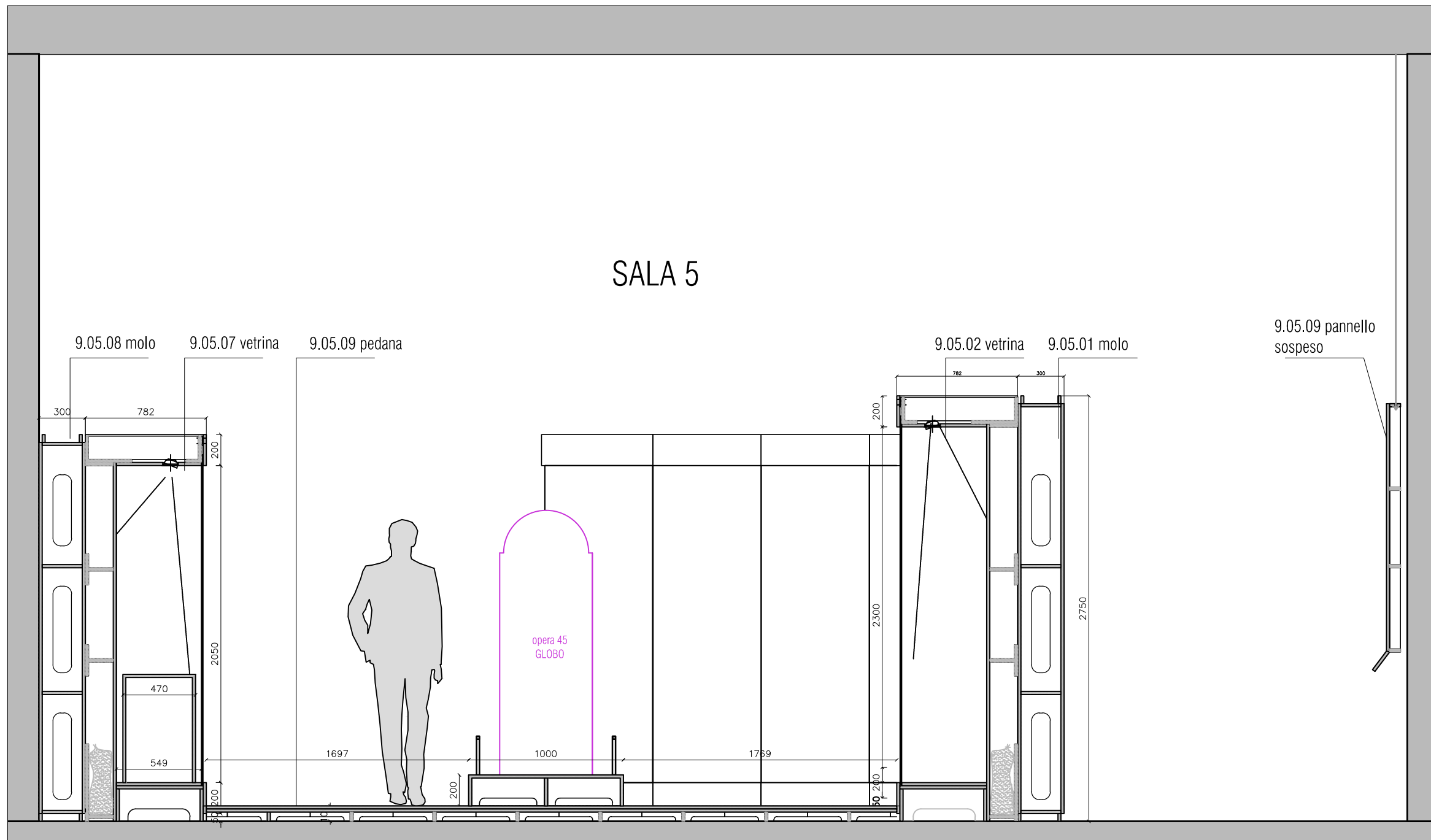

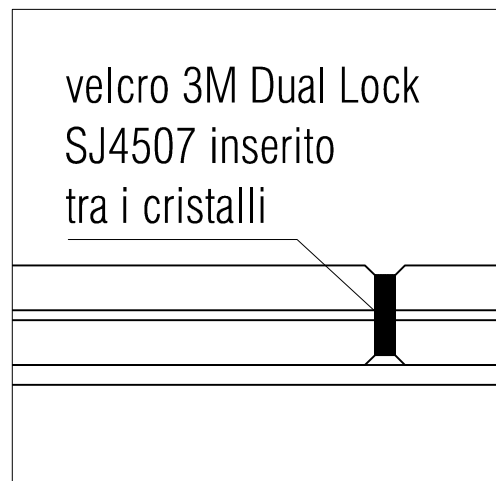
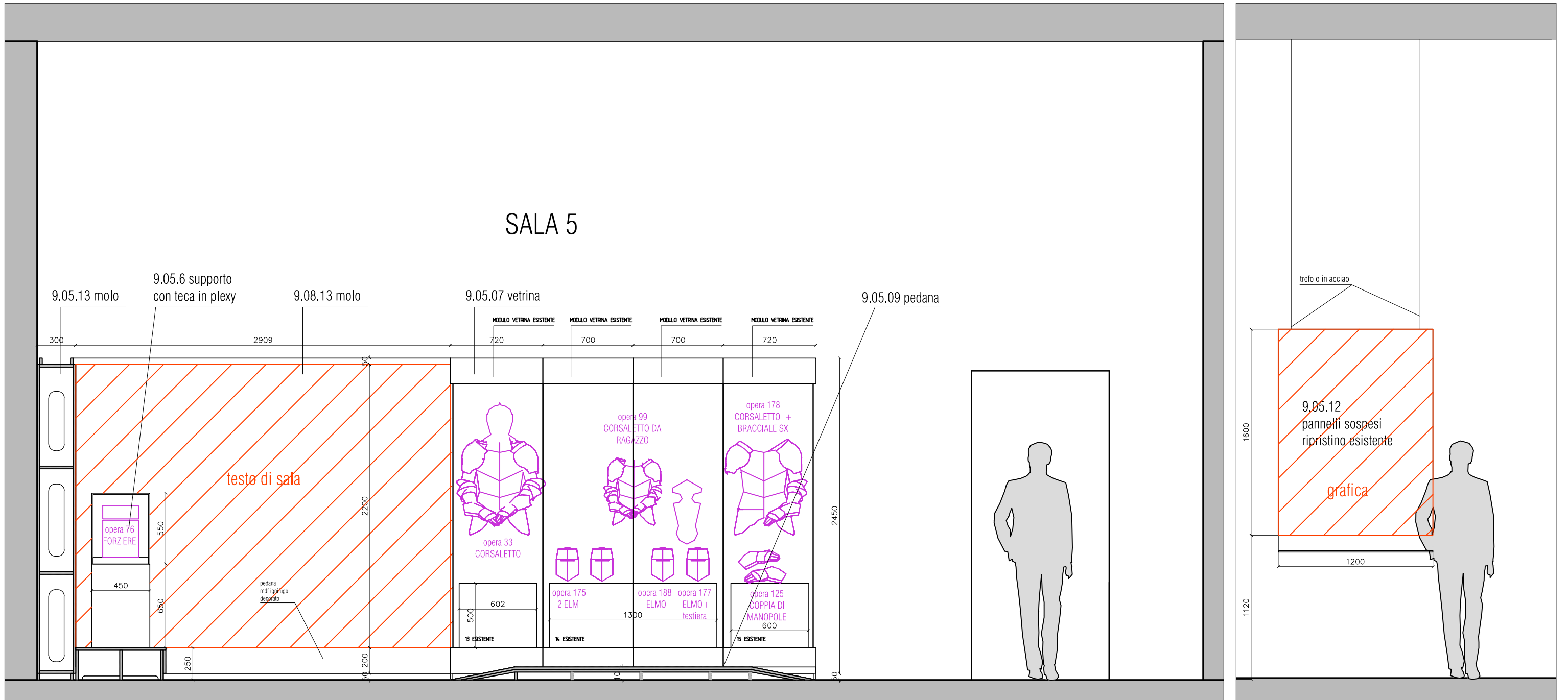

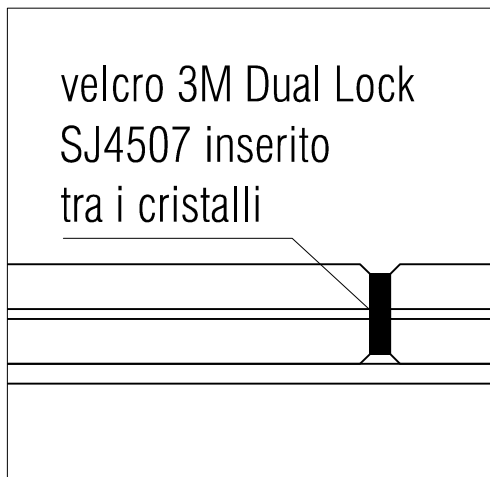
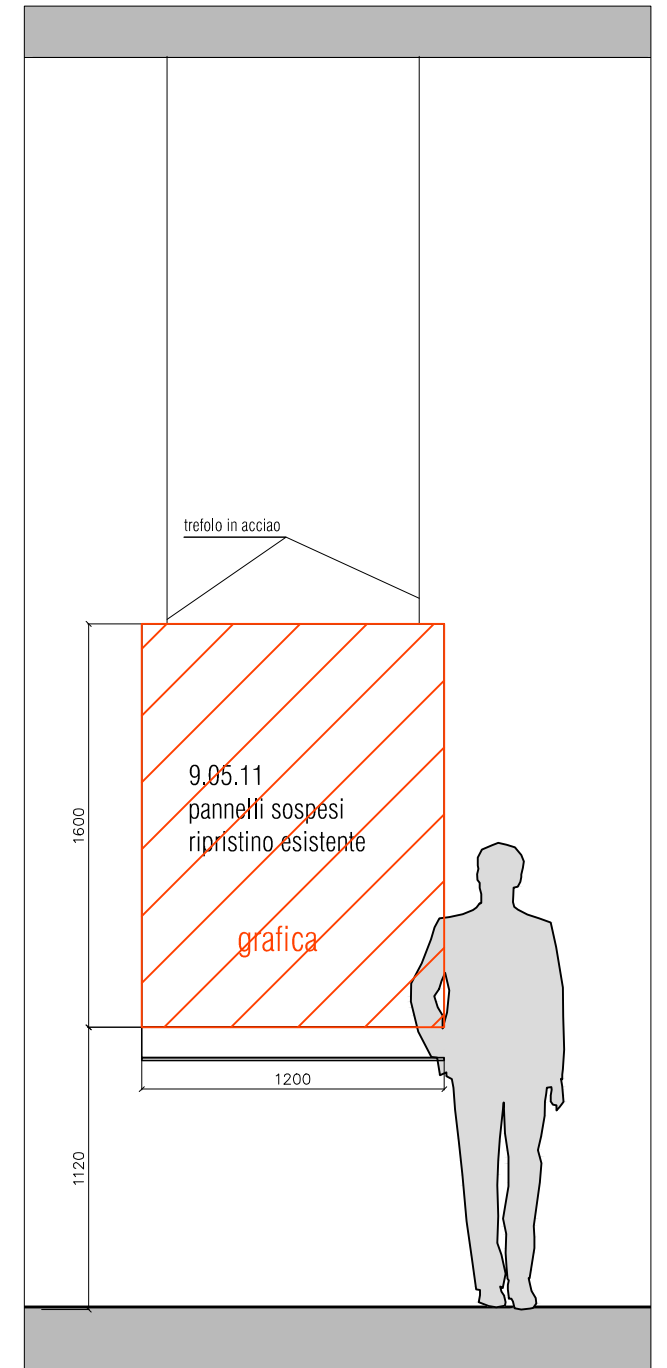
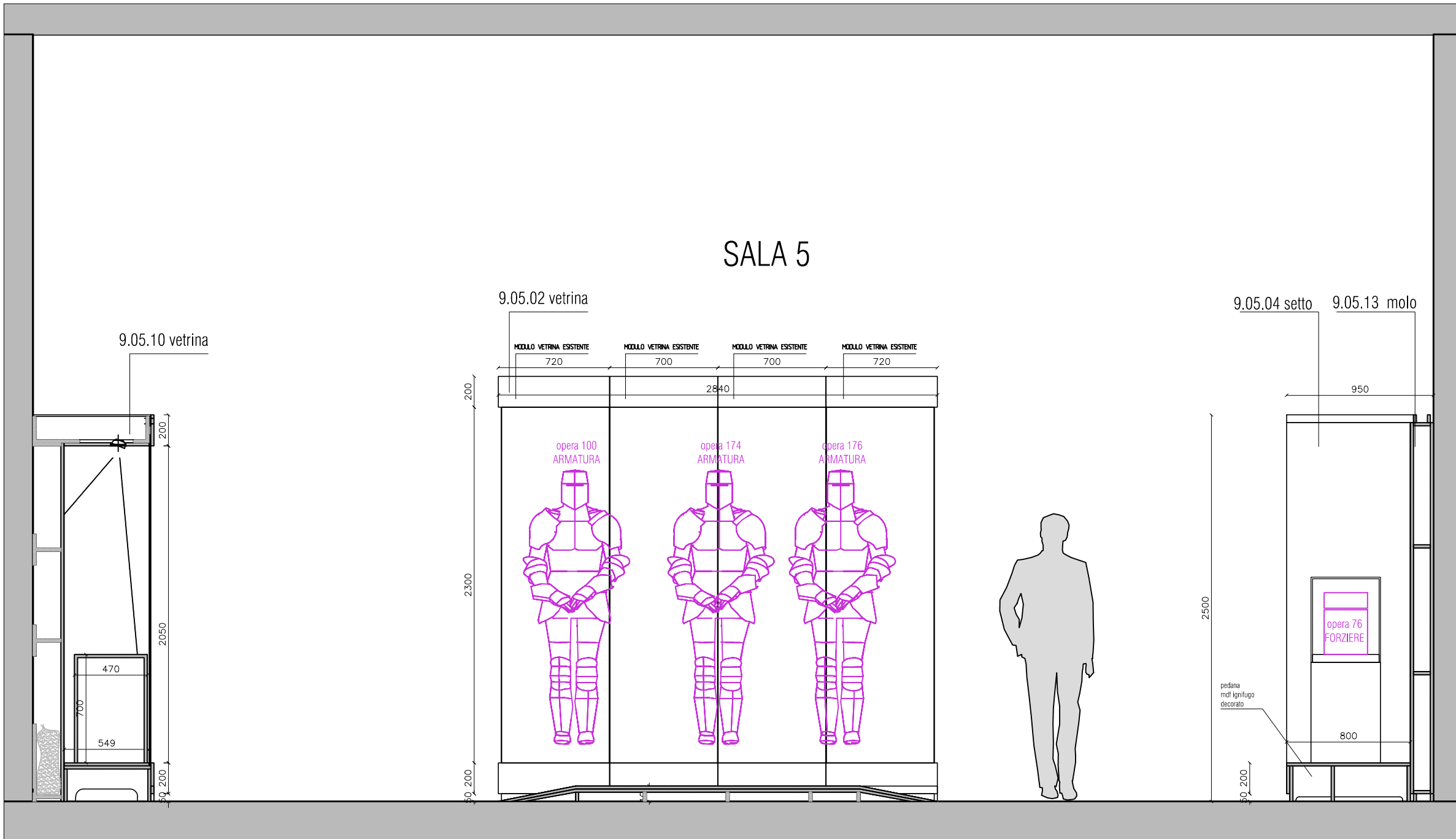

9.05.06 supporto con teca in plexy

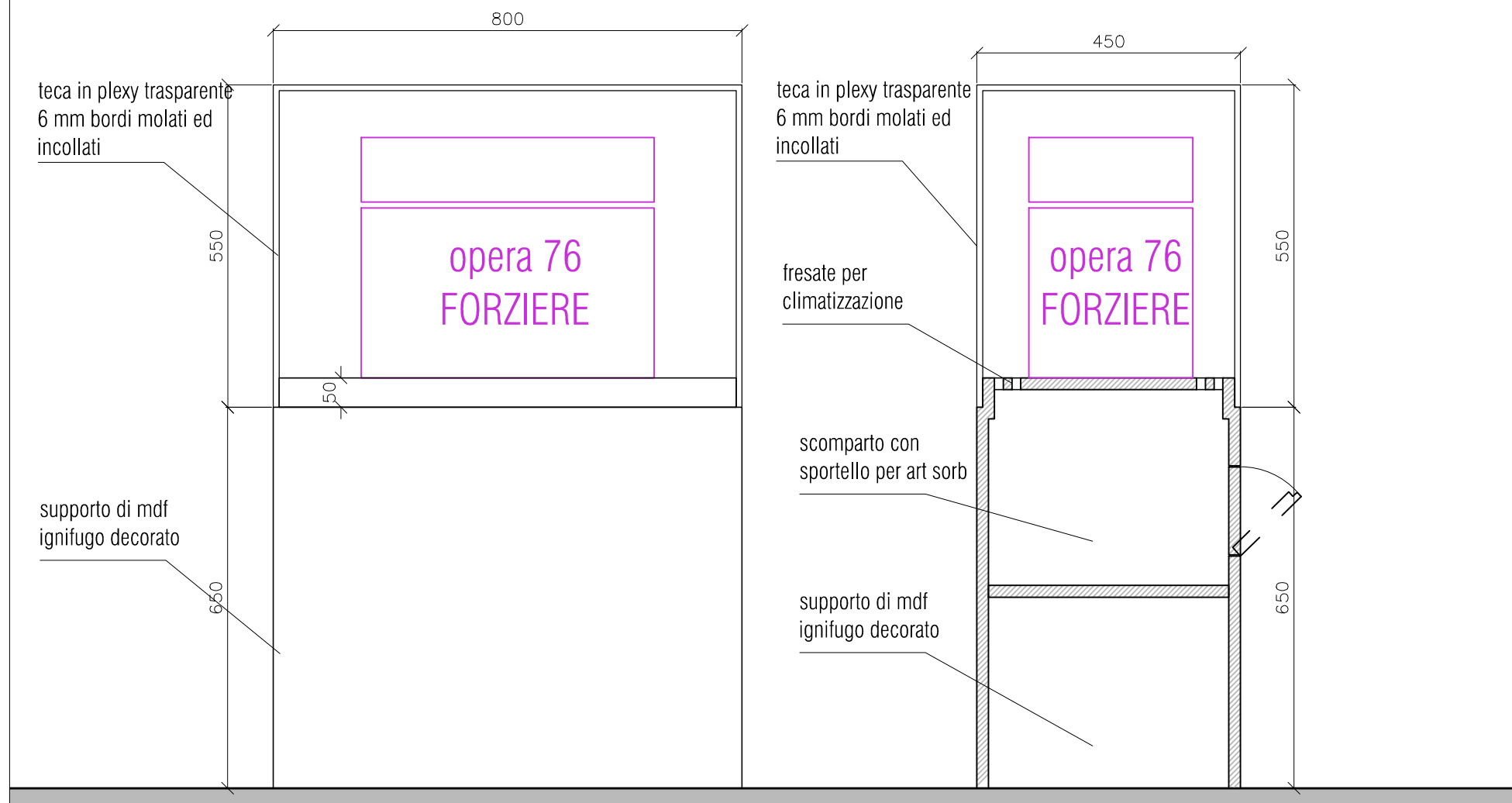

9.05.09 pedana + espositore

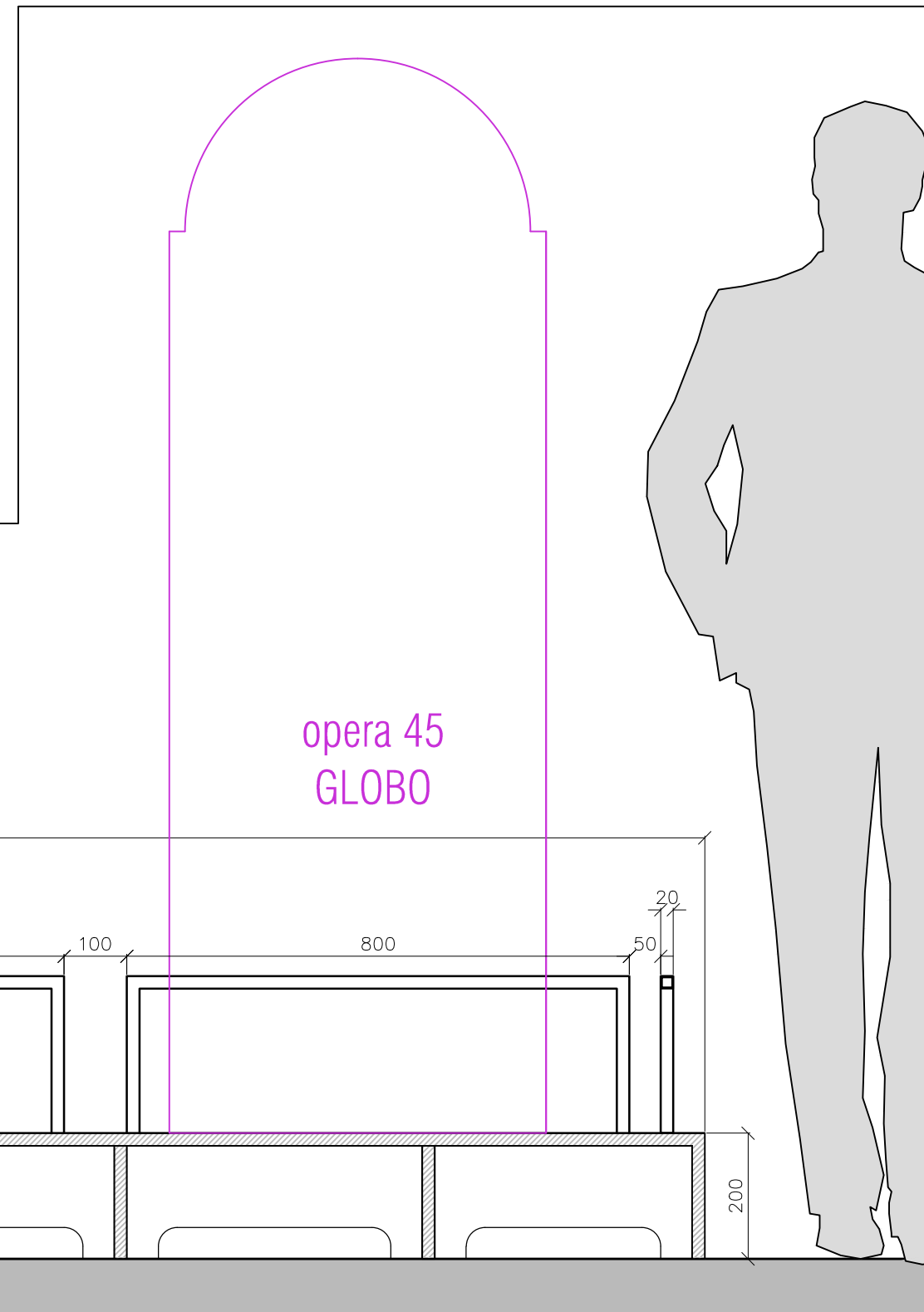
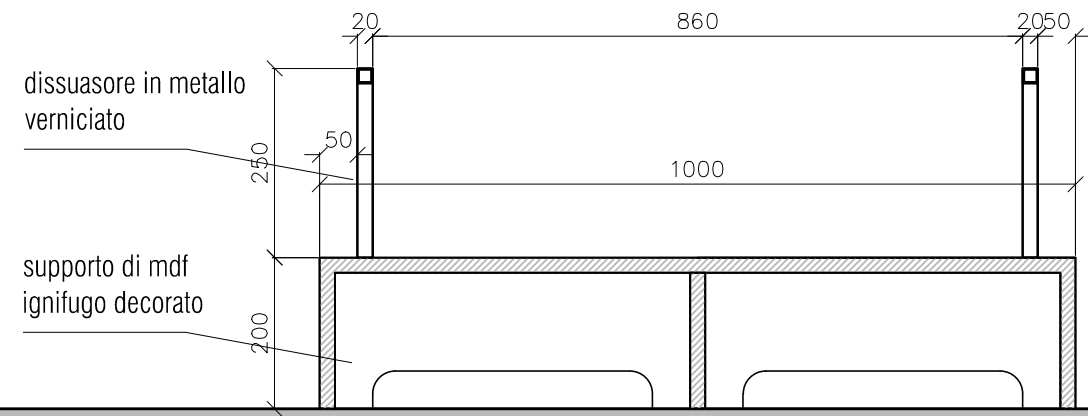

dissuasore in ferro verniciato

pedana mdf ignifugo decorato

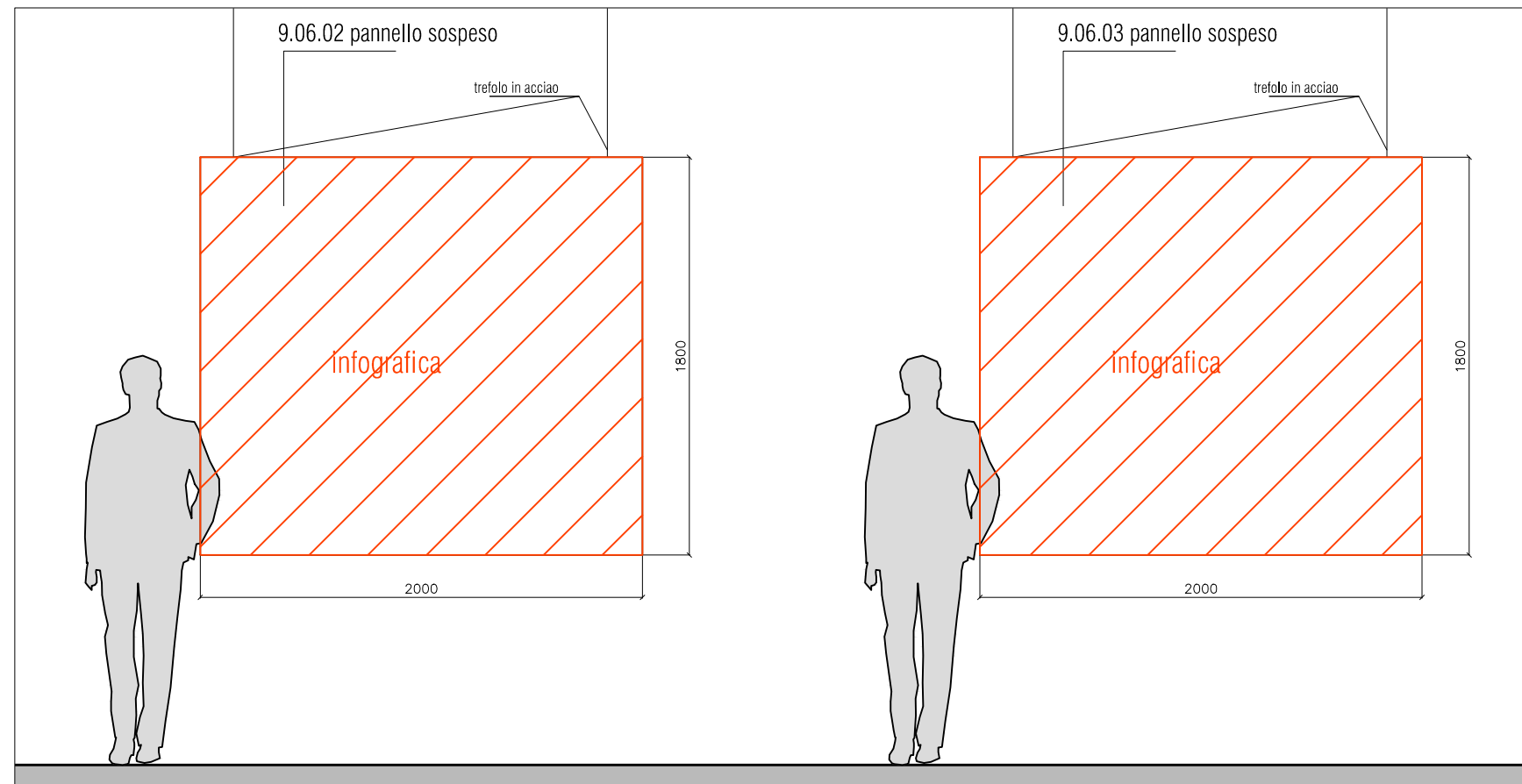
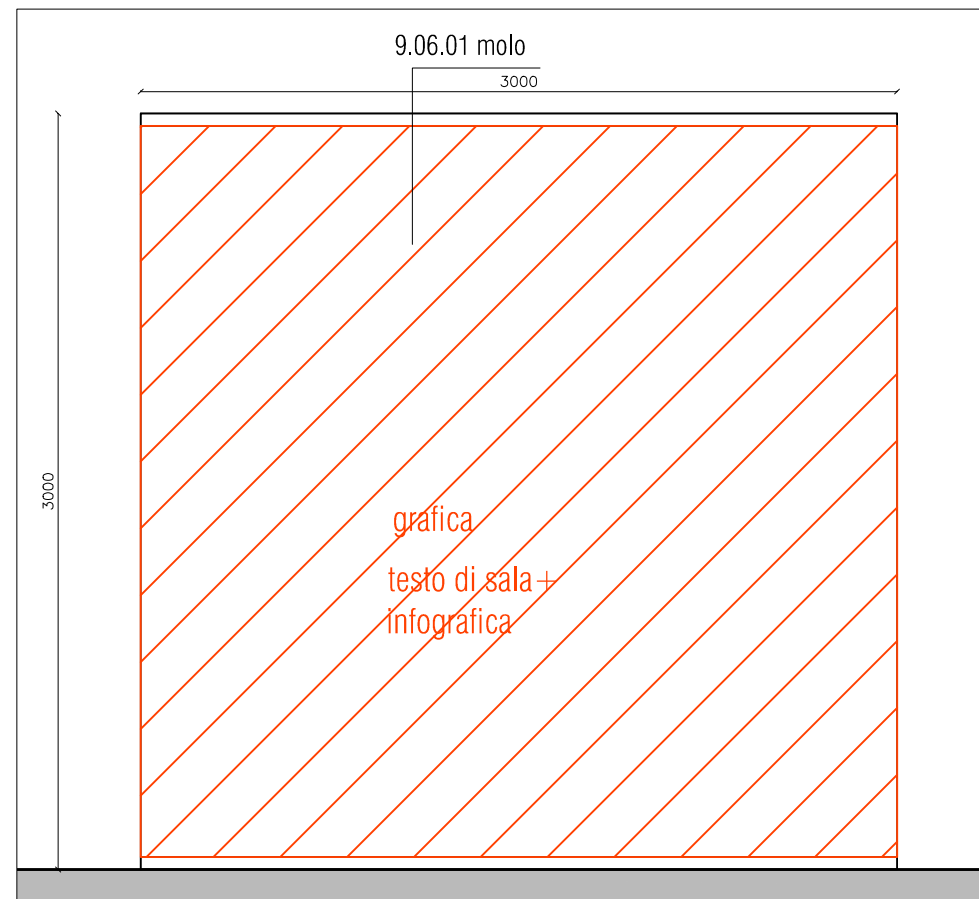
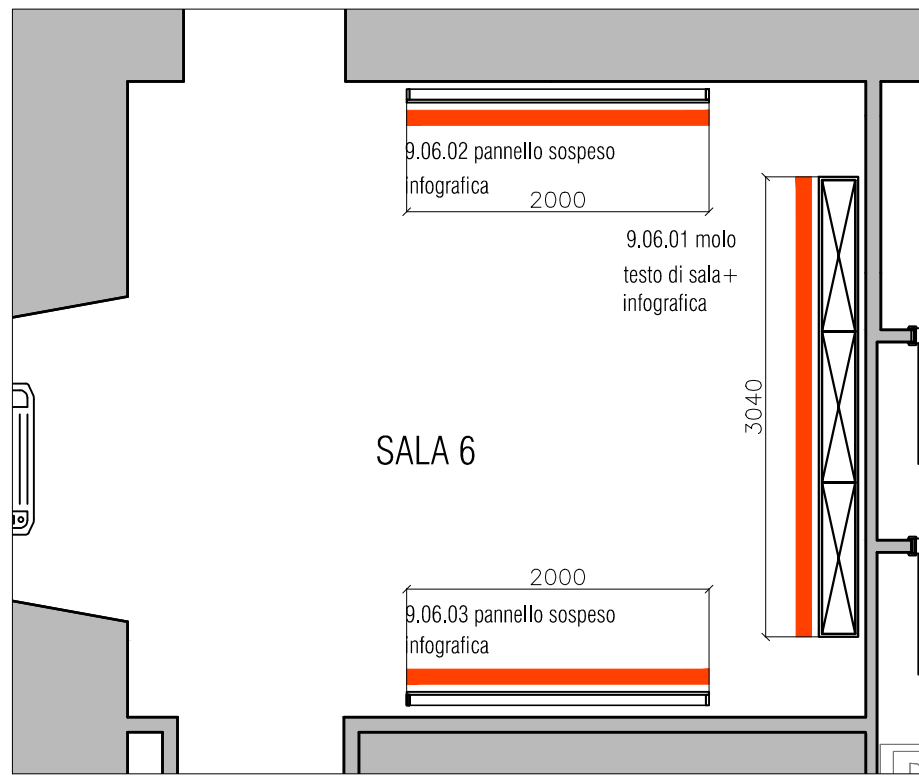

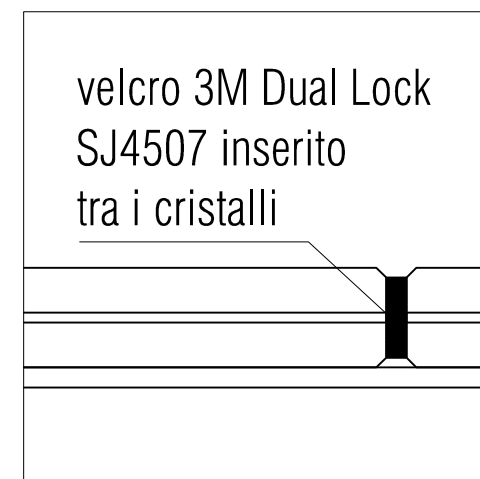
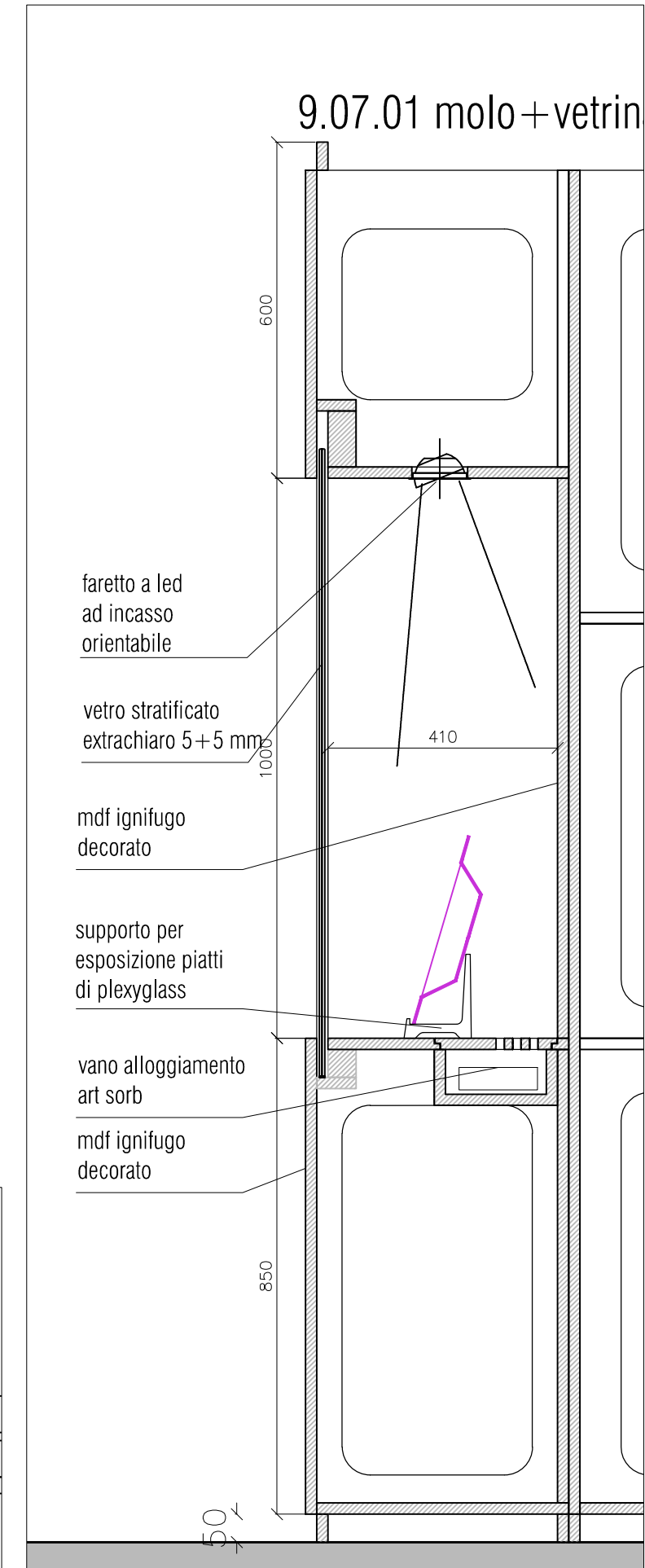
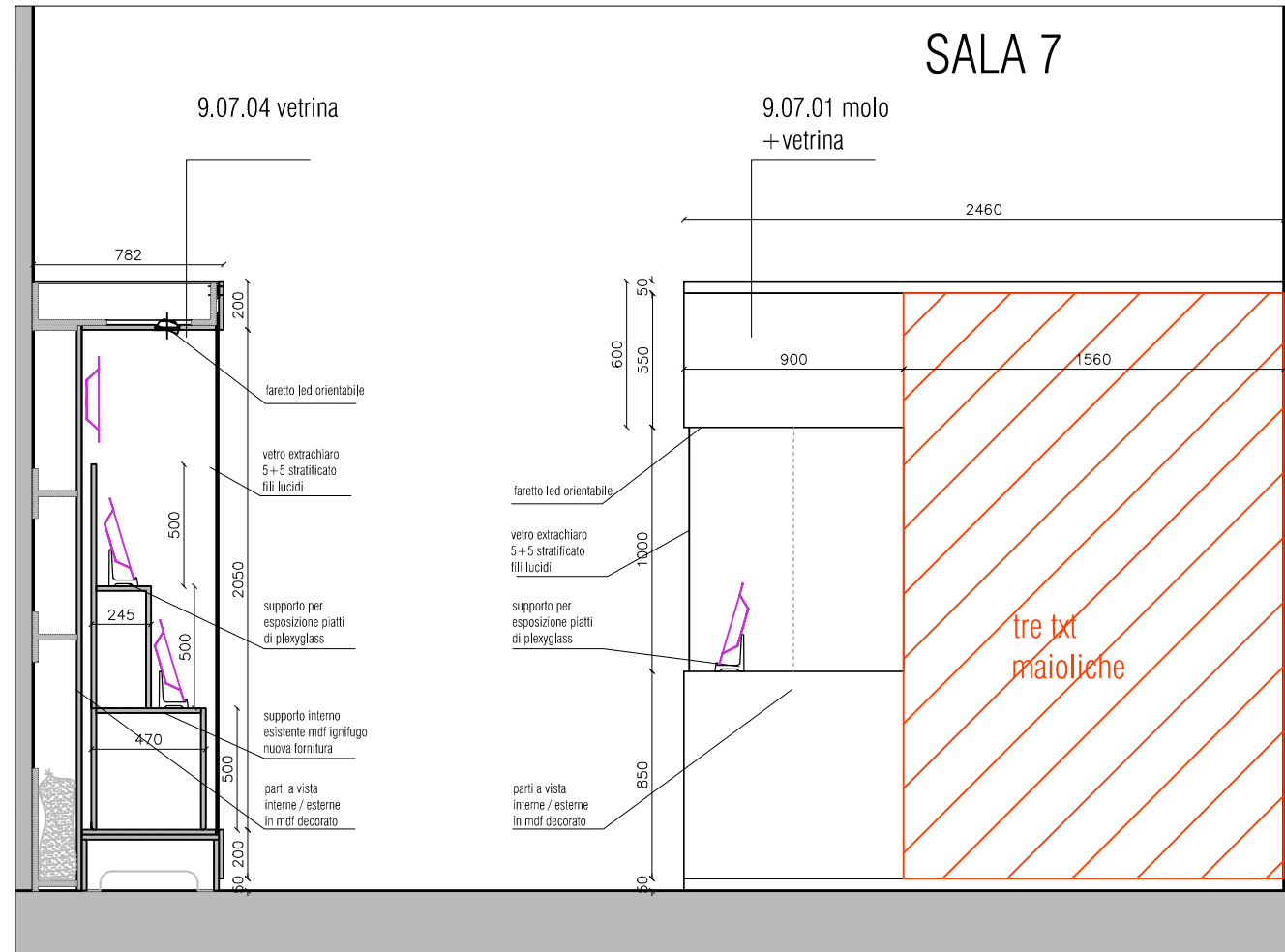
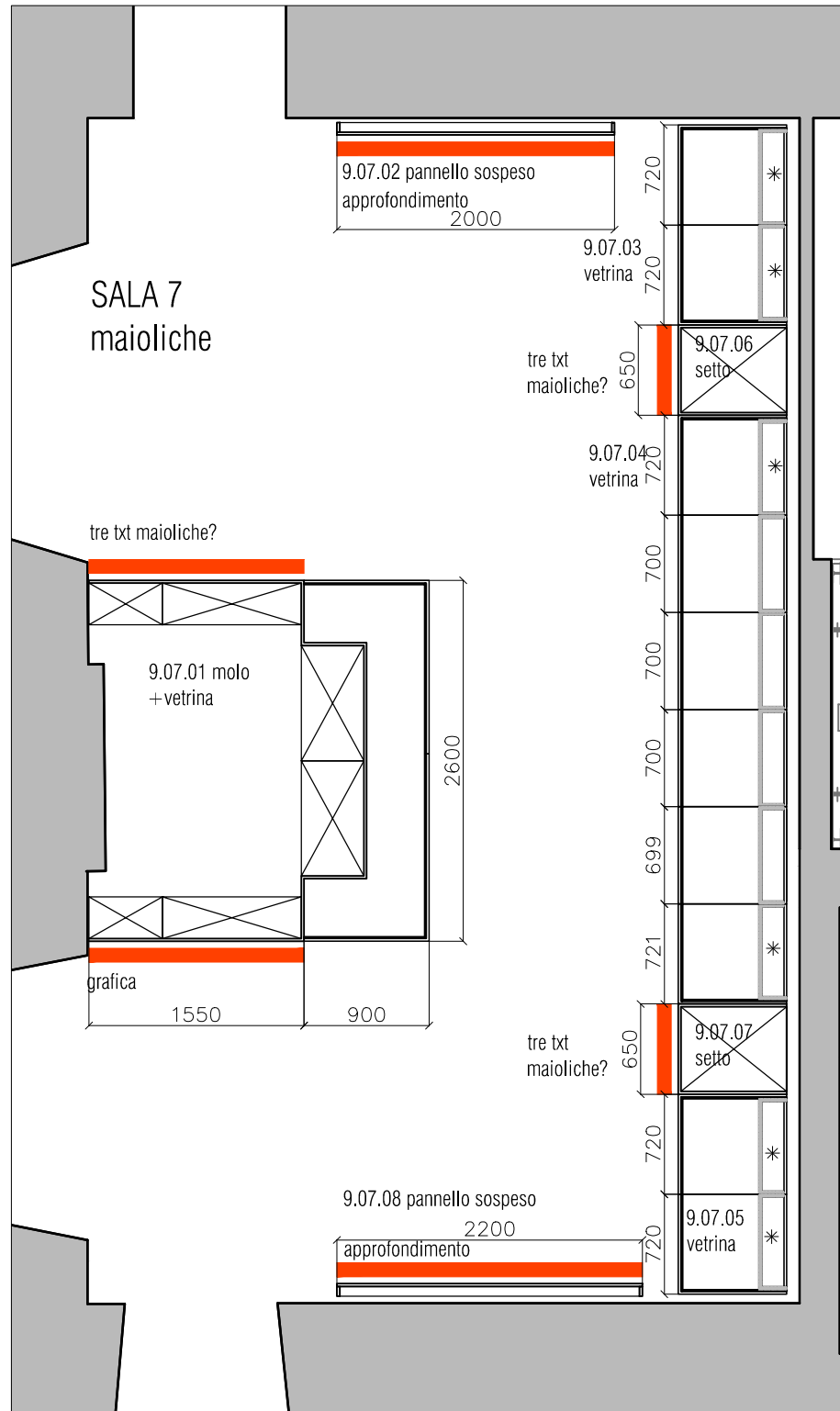

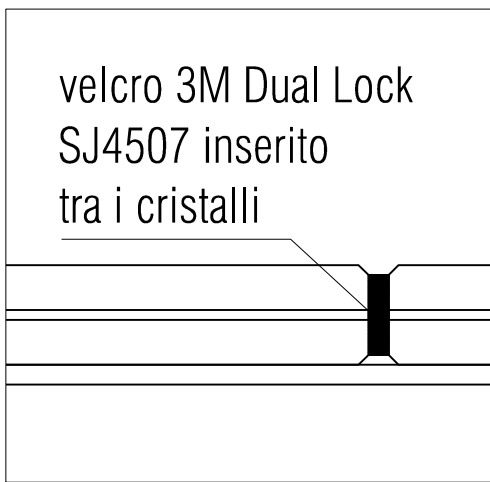
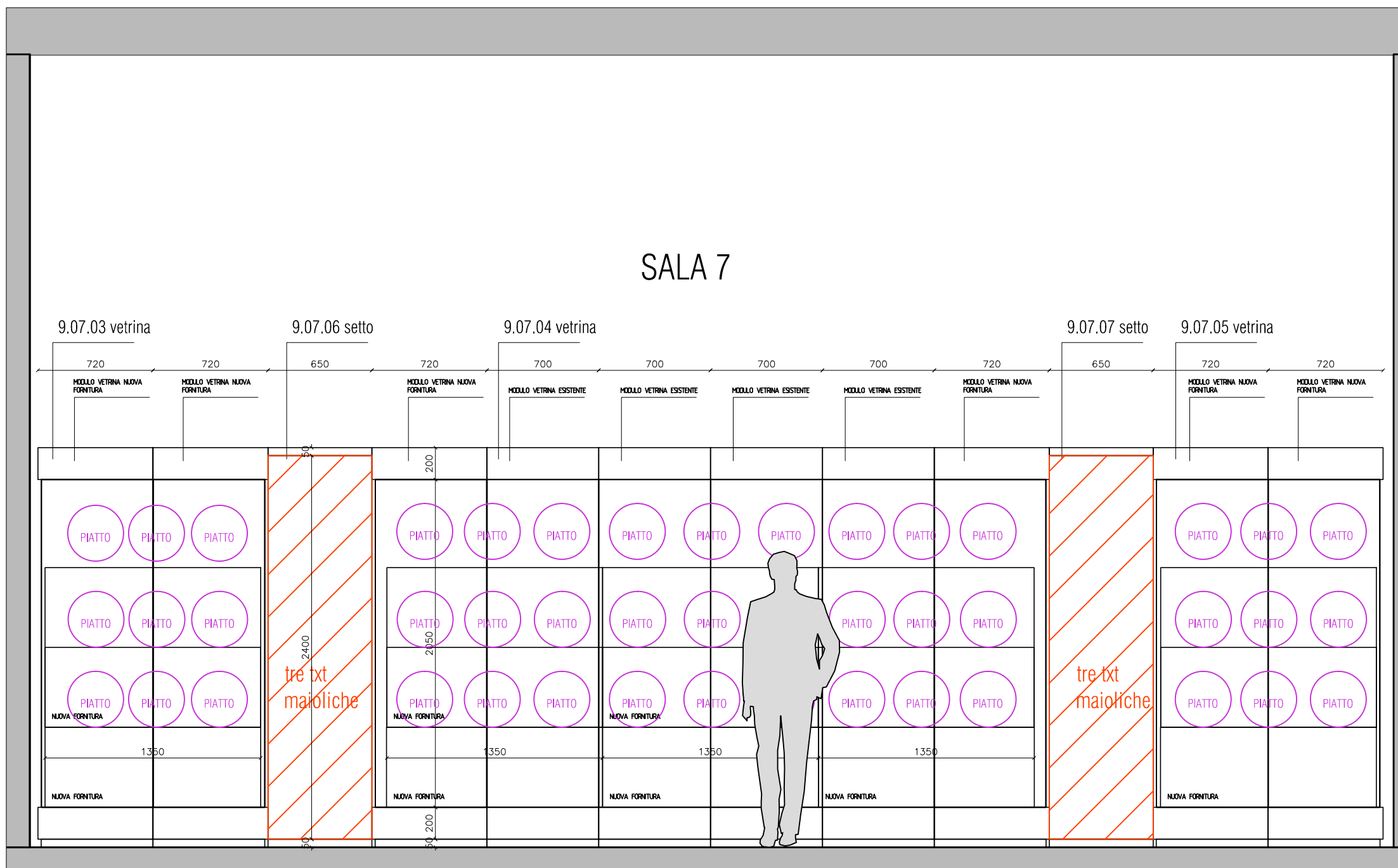

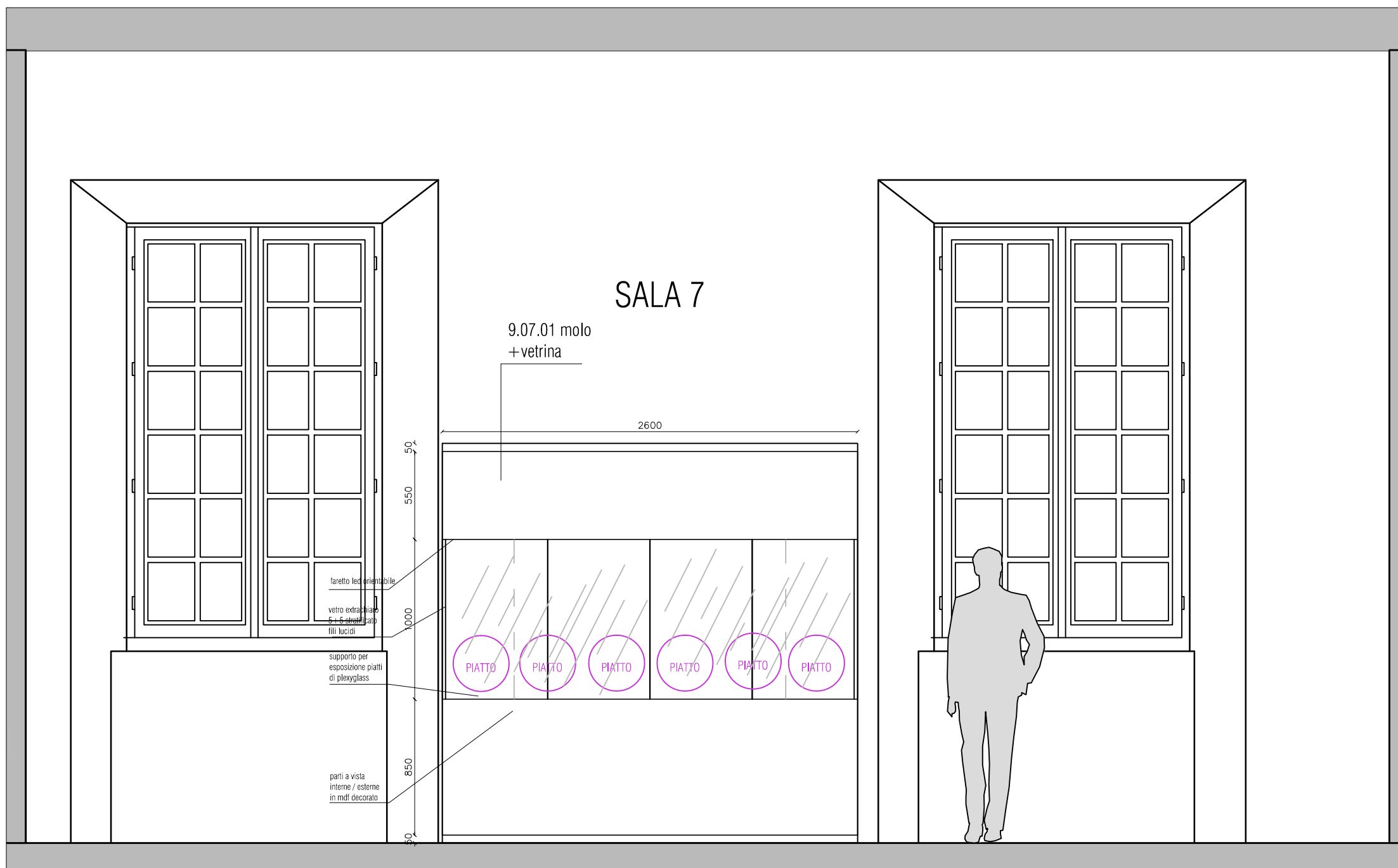

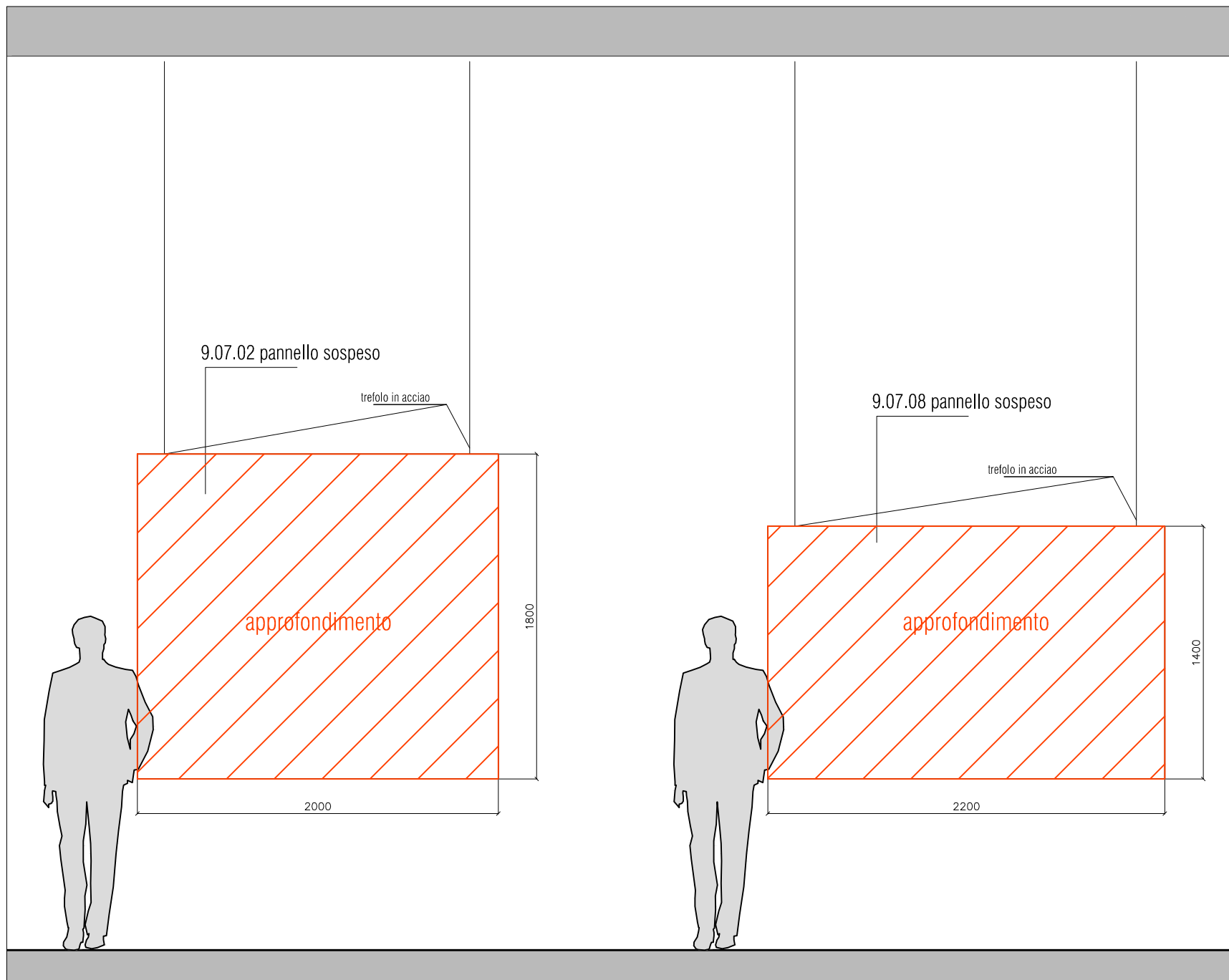

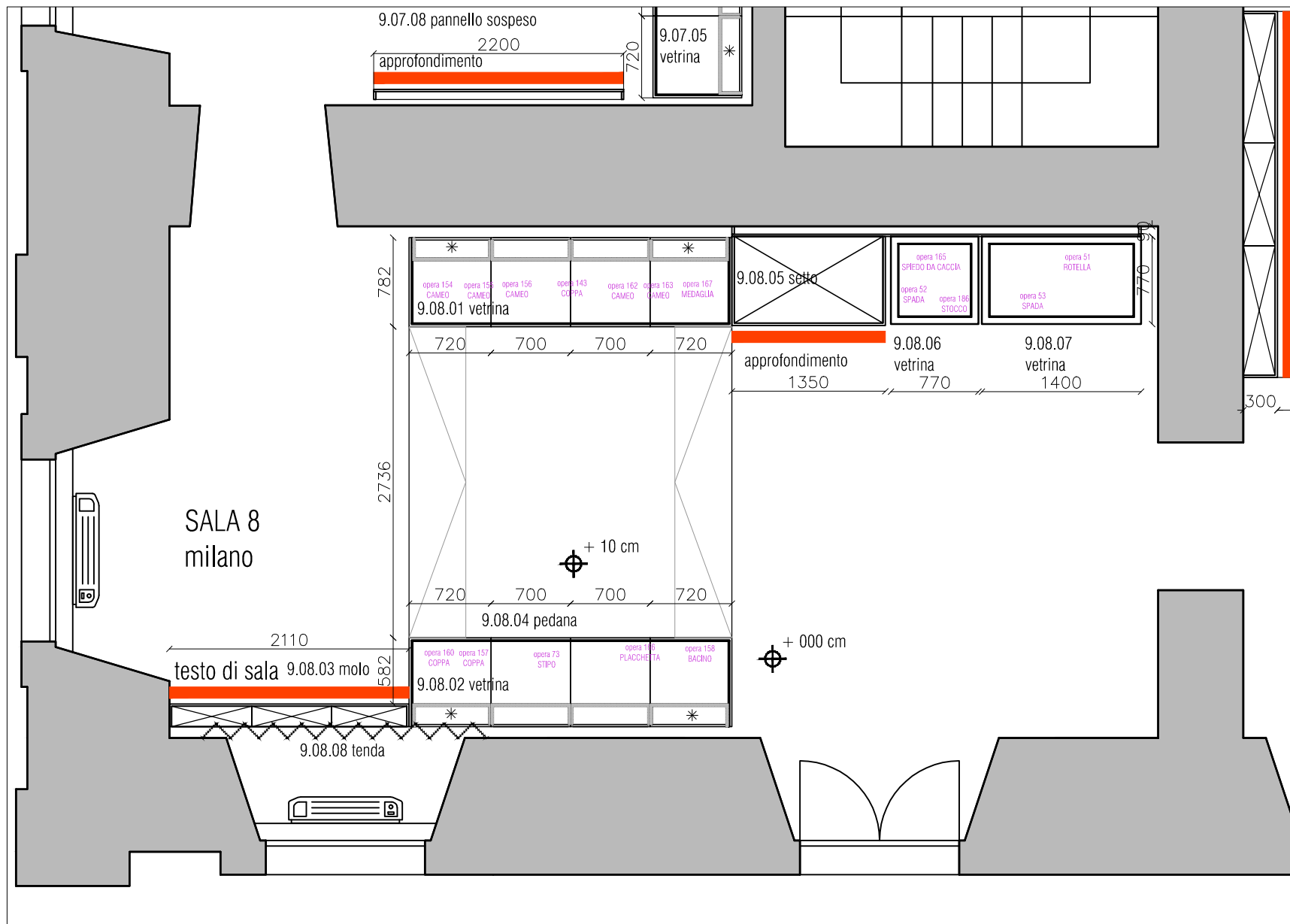

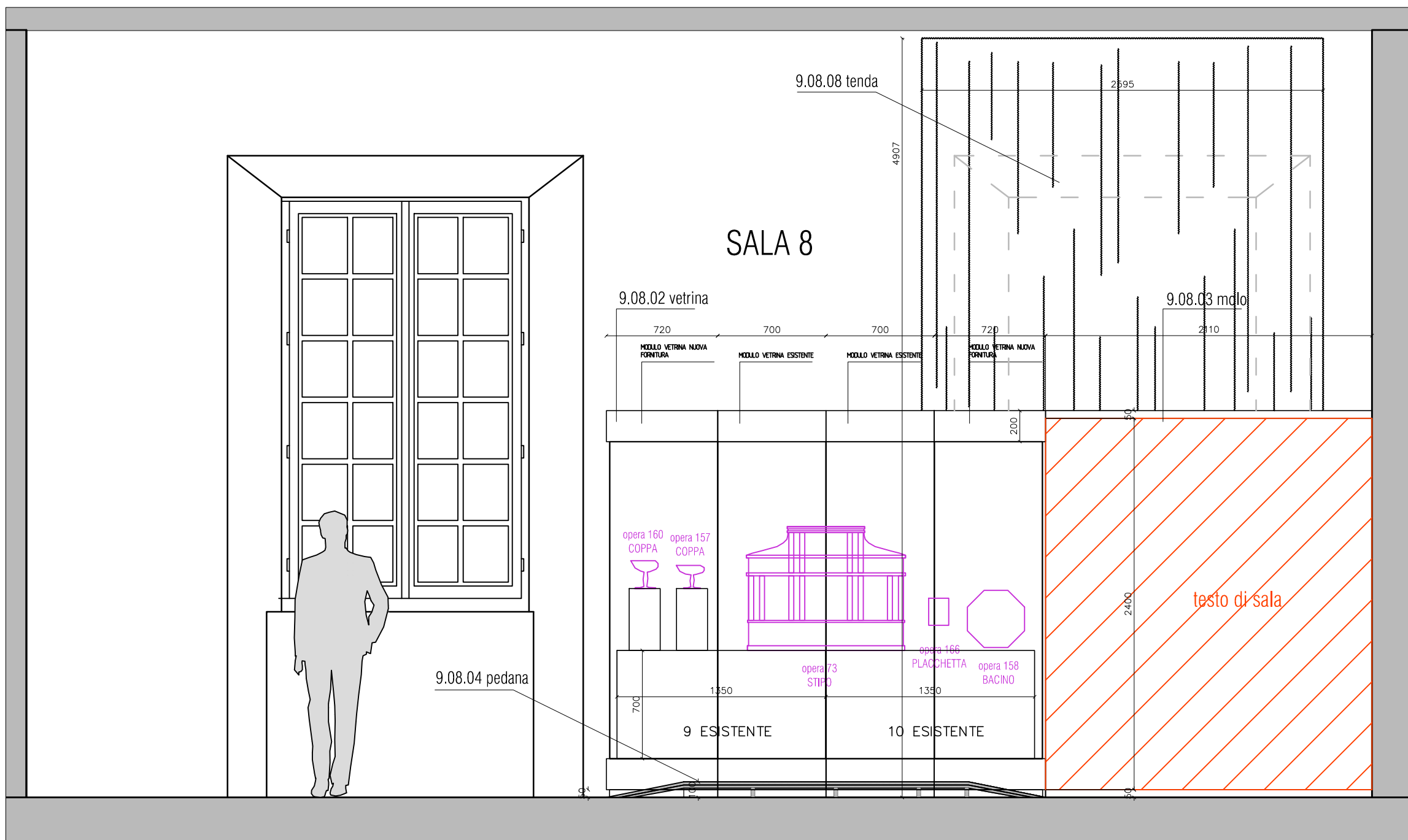

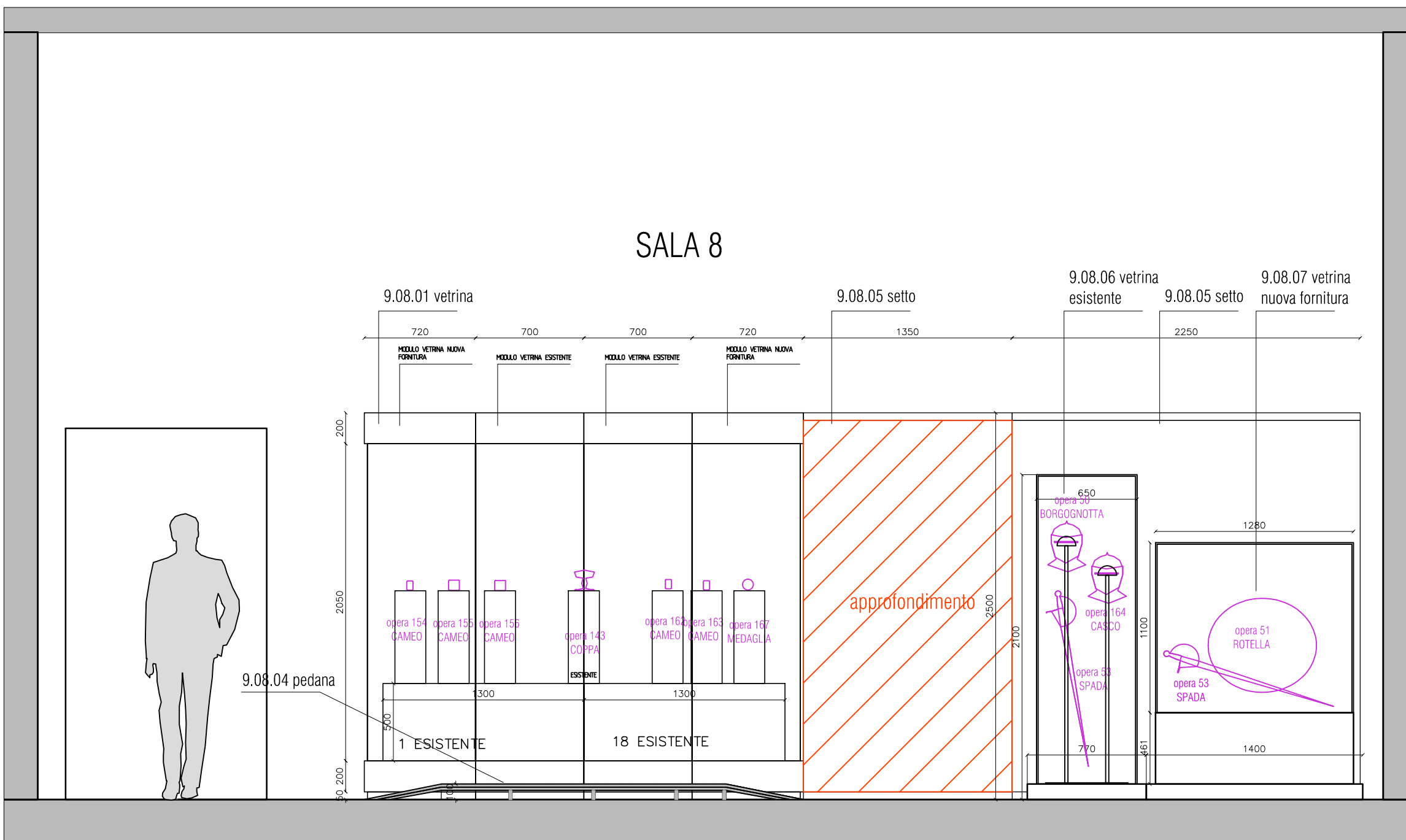

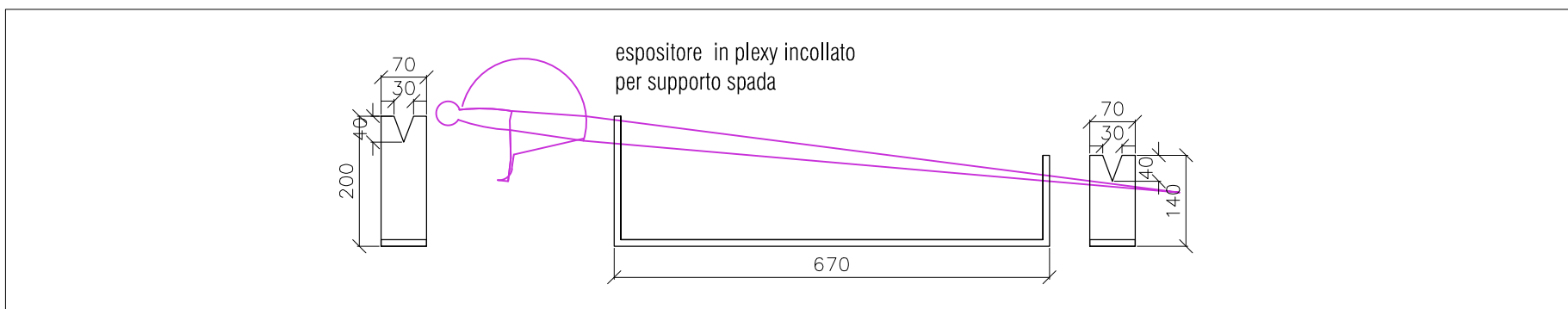
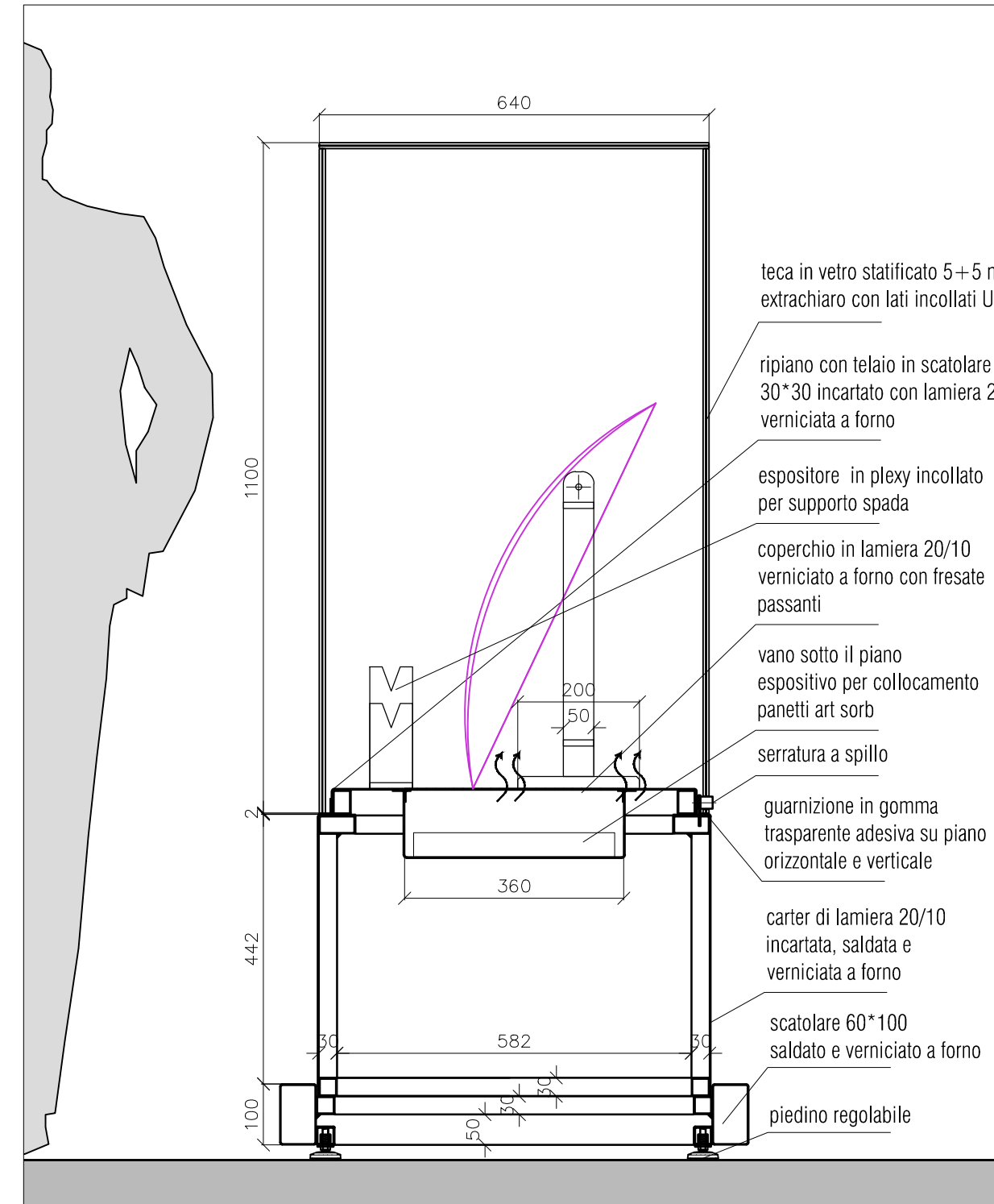
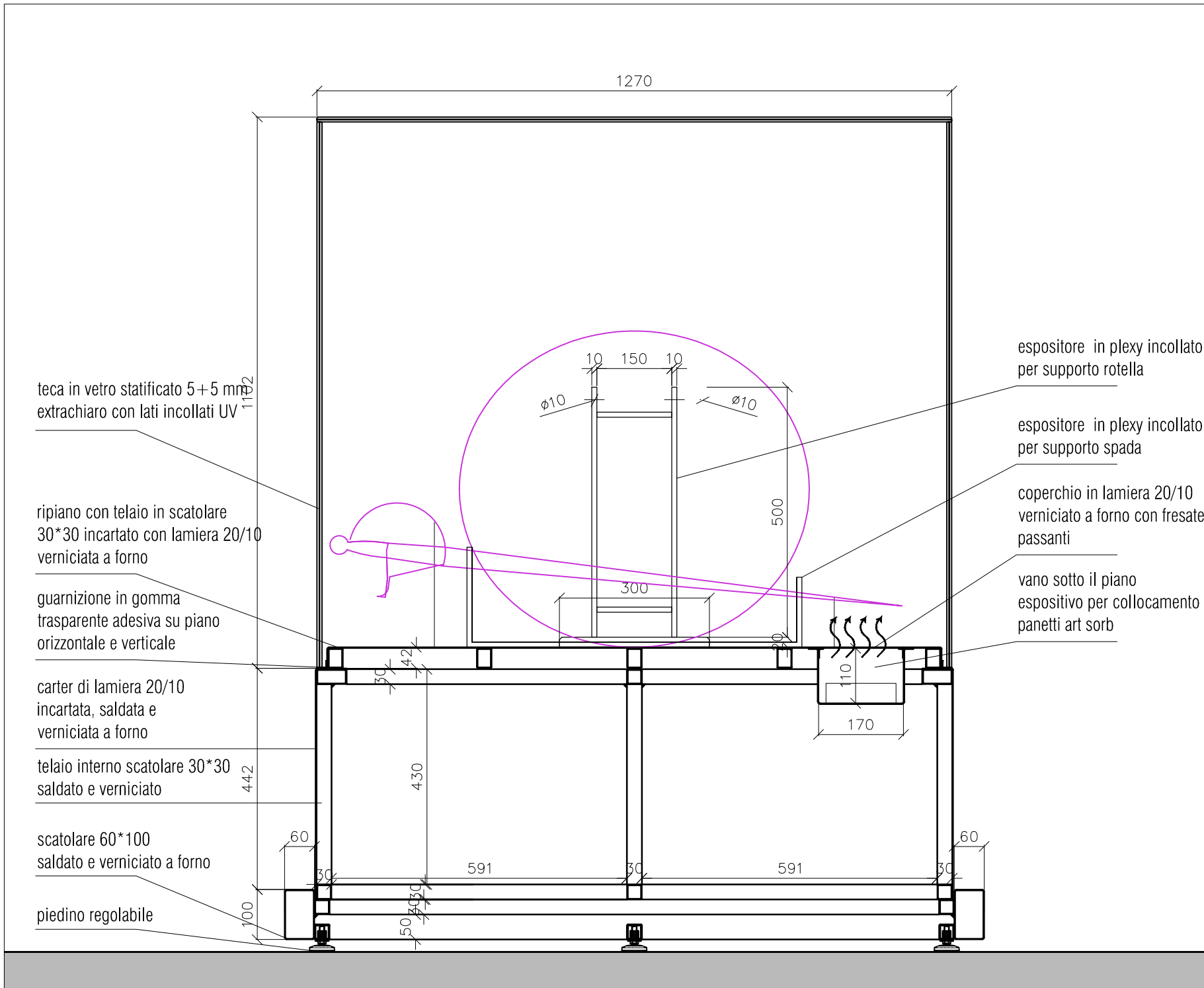

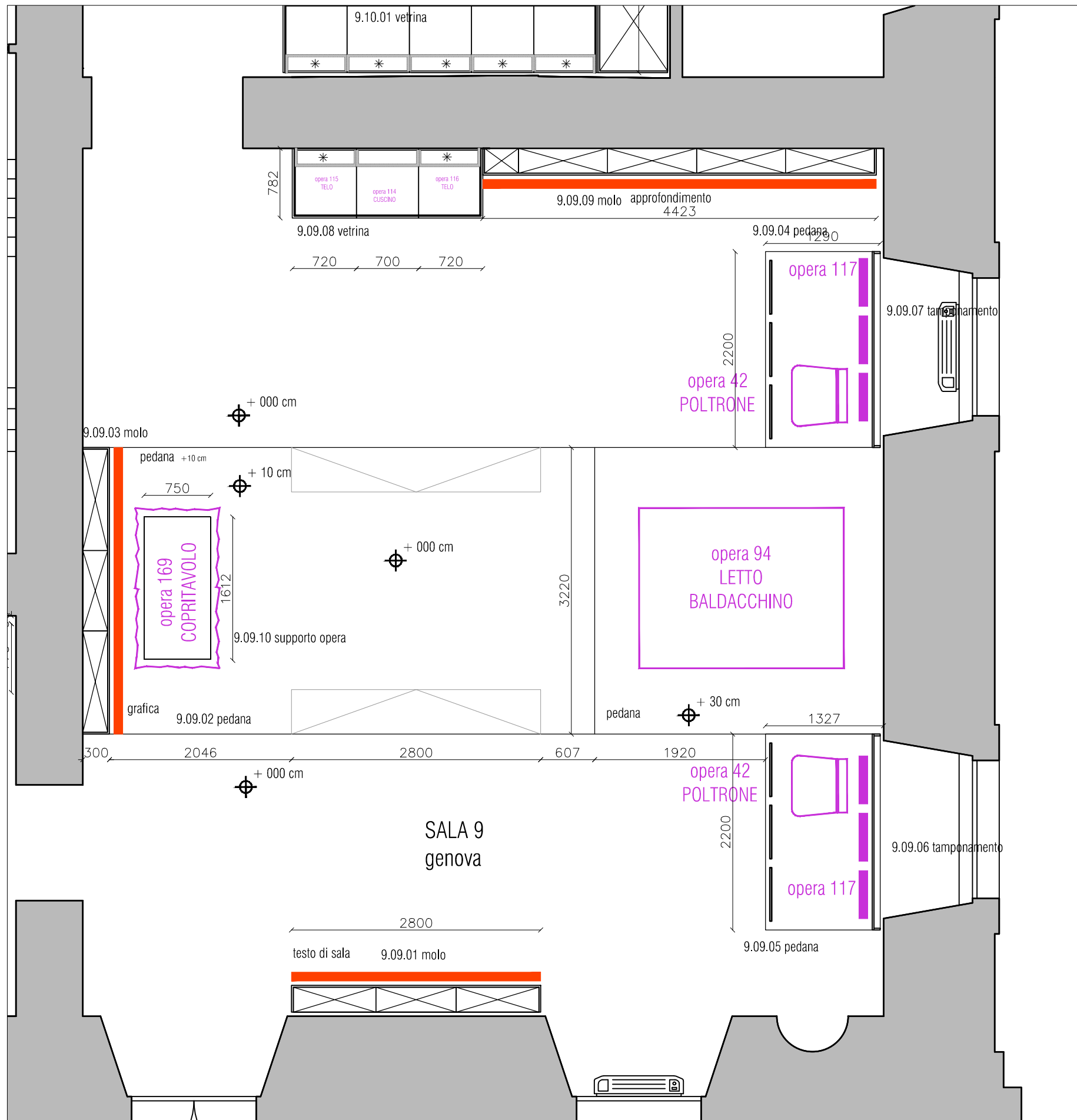

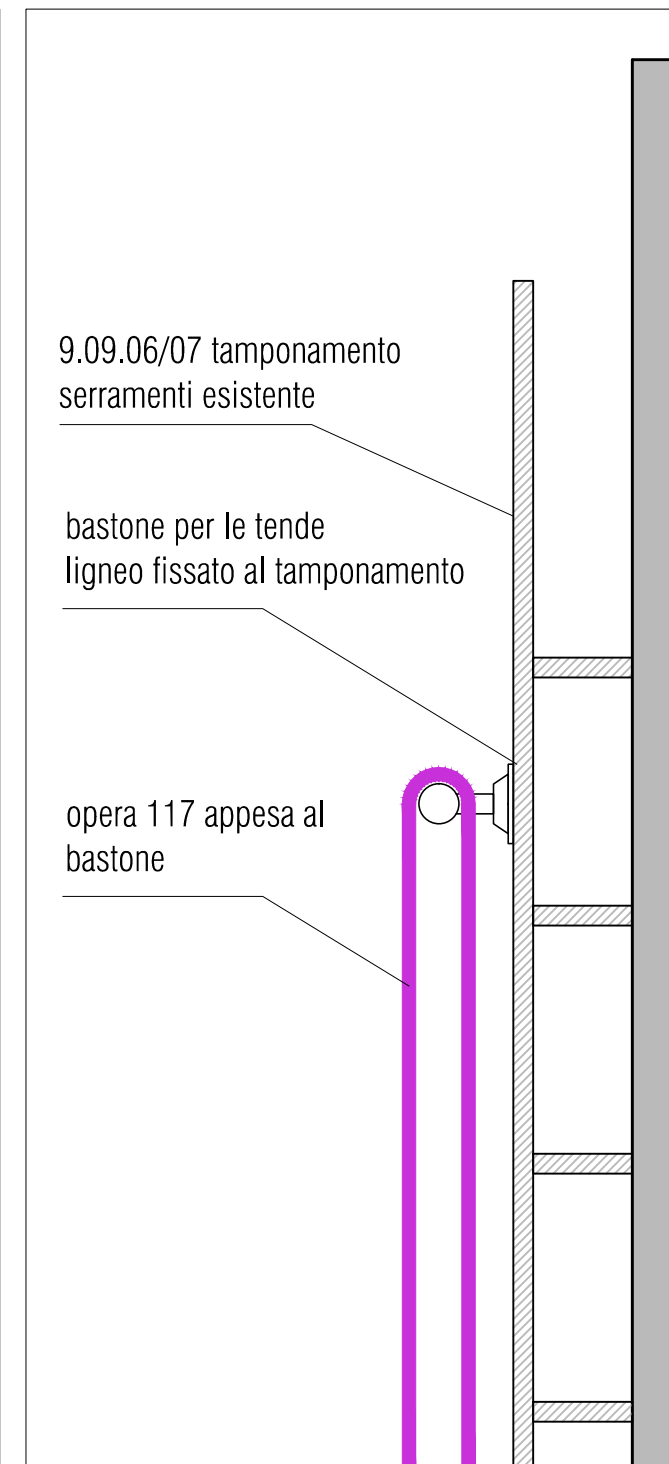
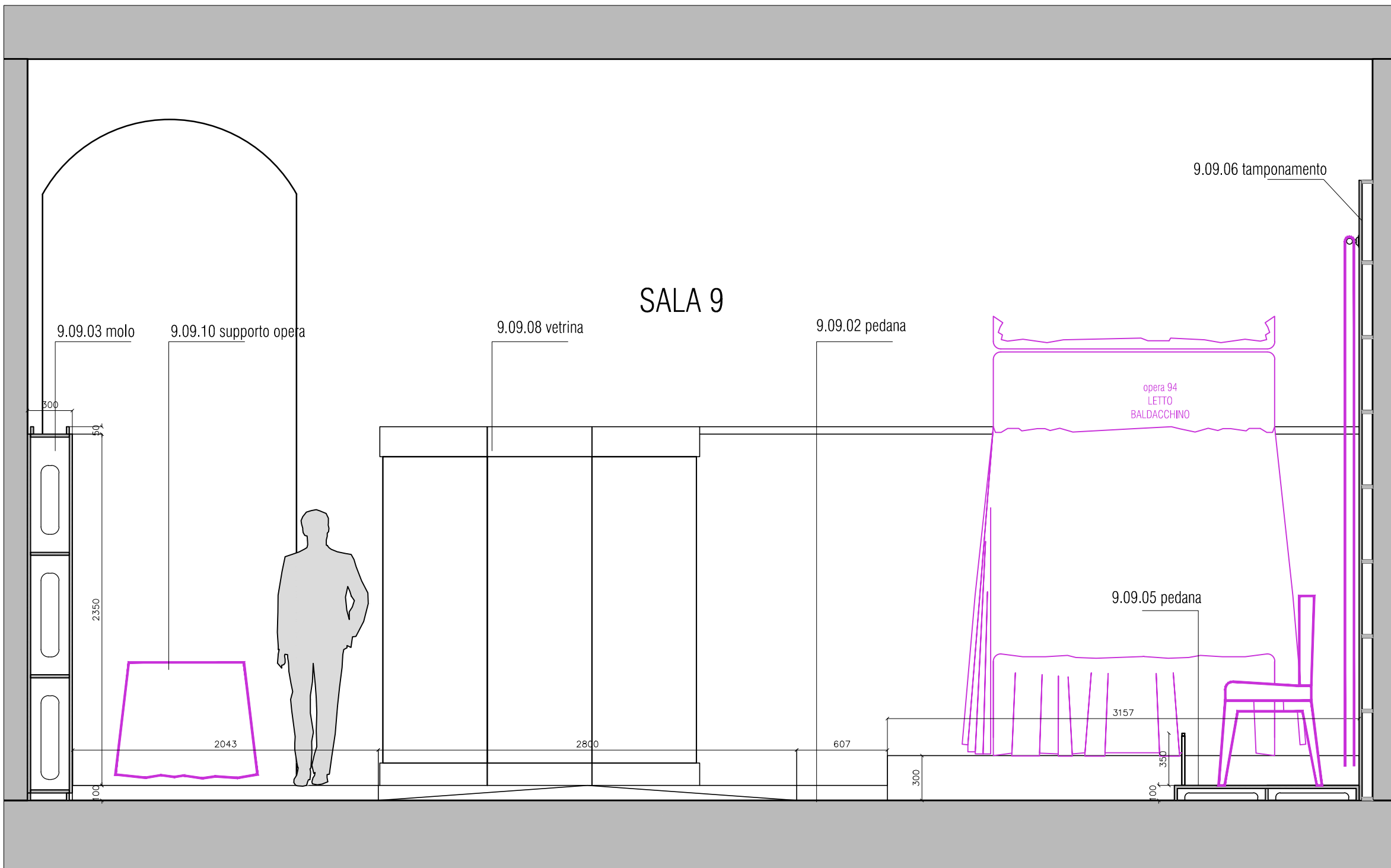

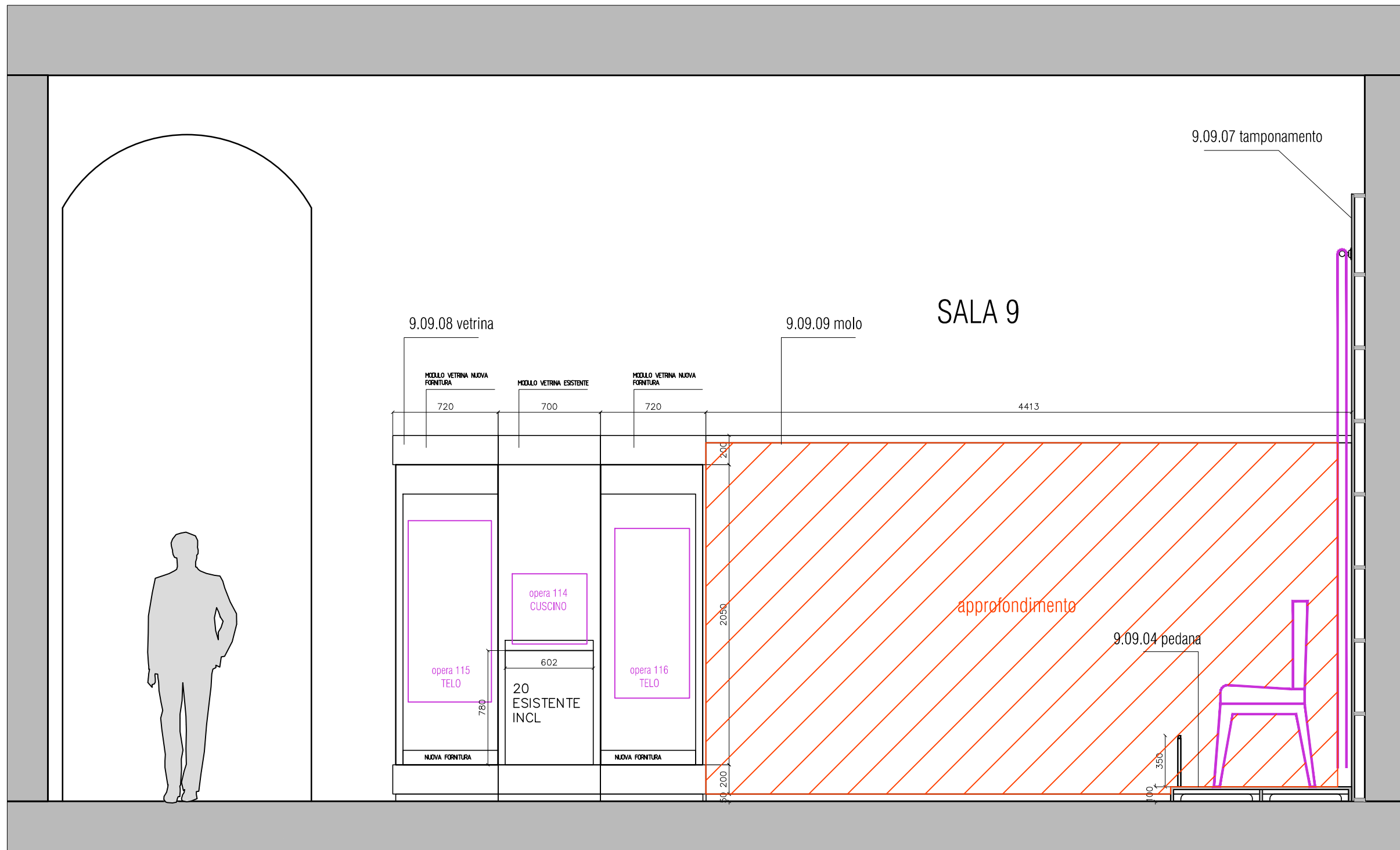

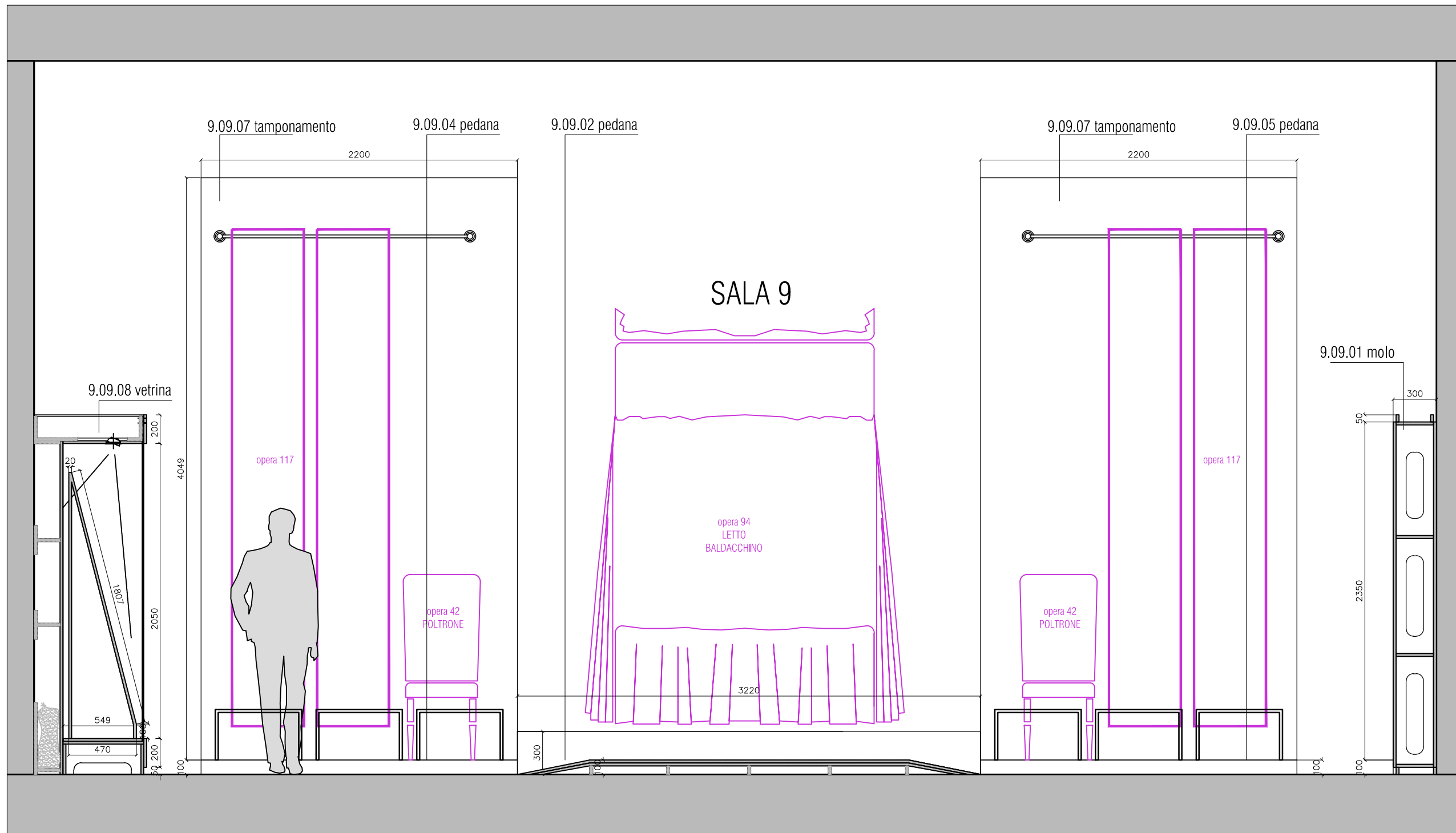

9.09.08 vetrina

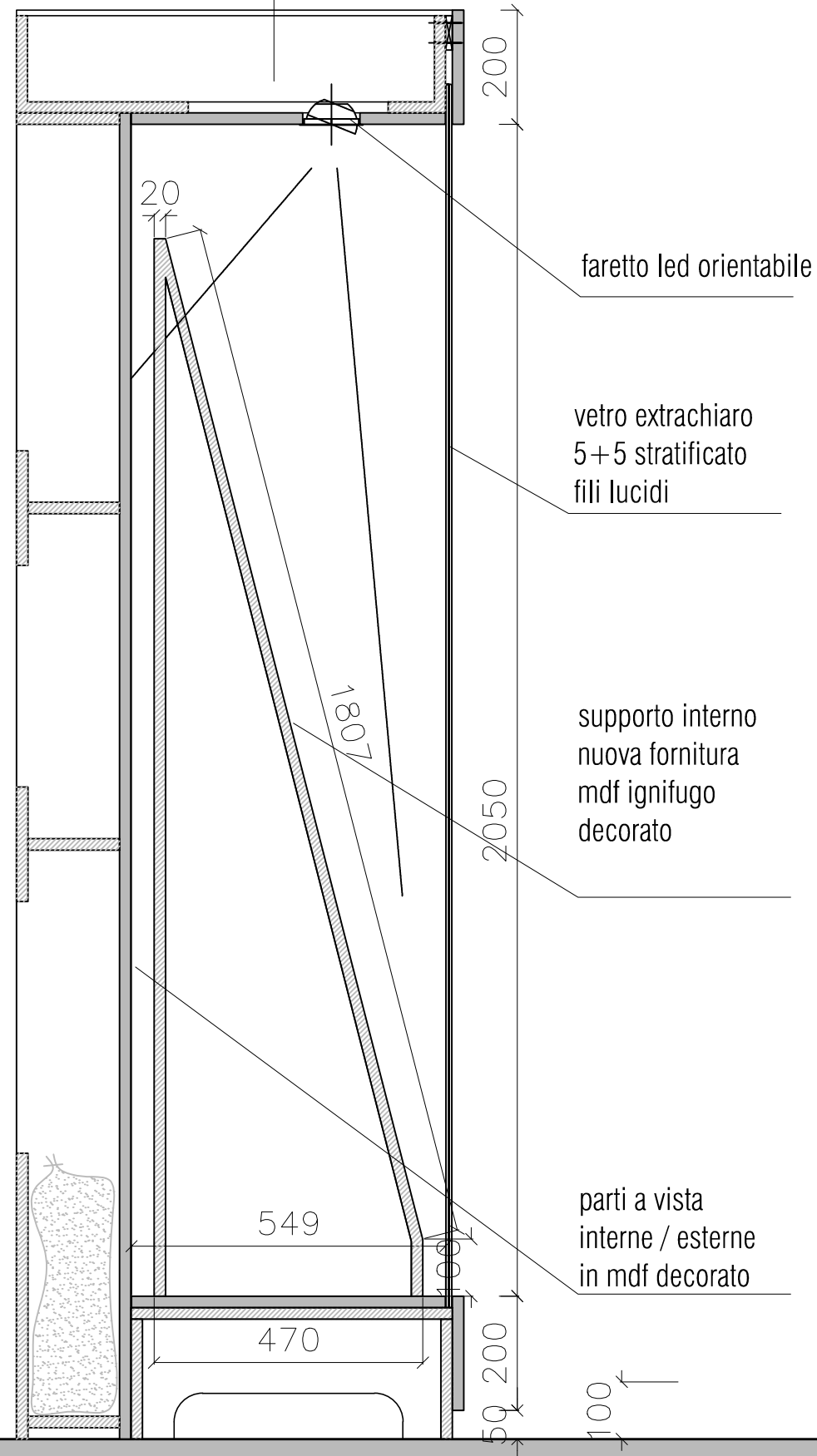

supporto interno n.2 pezzi

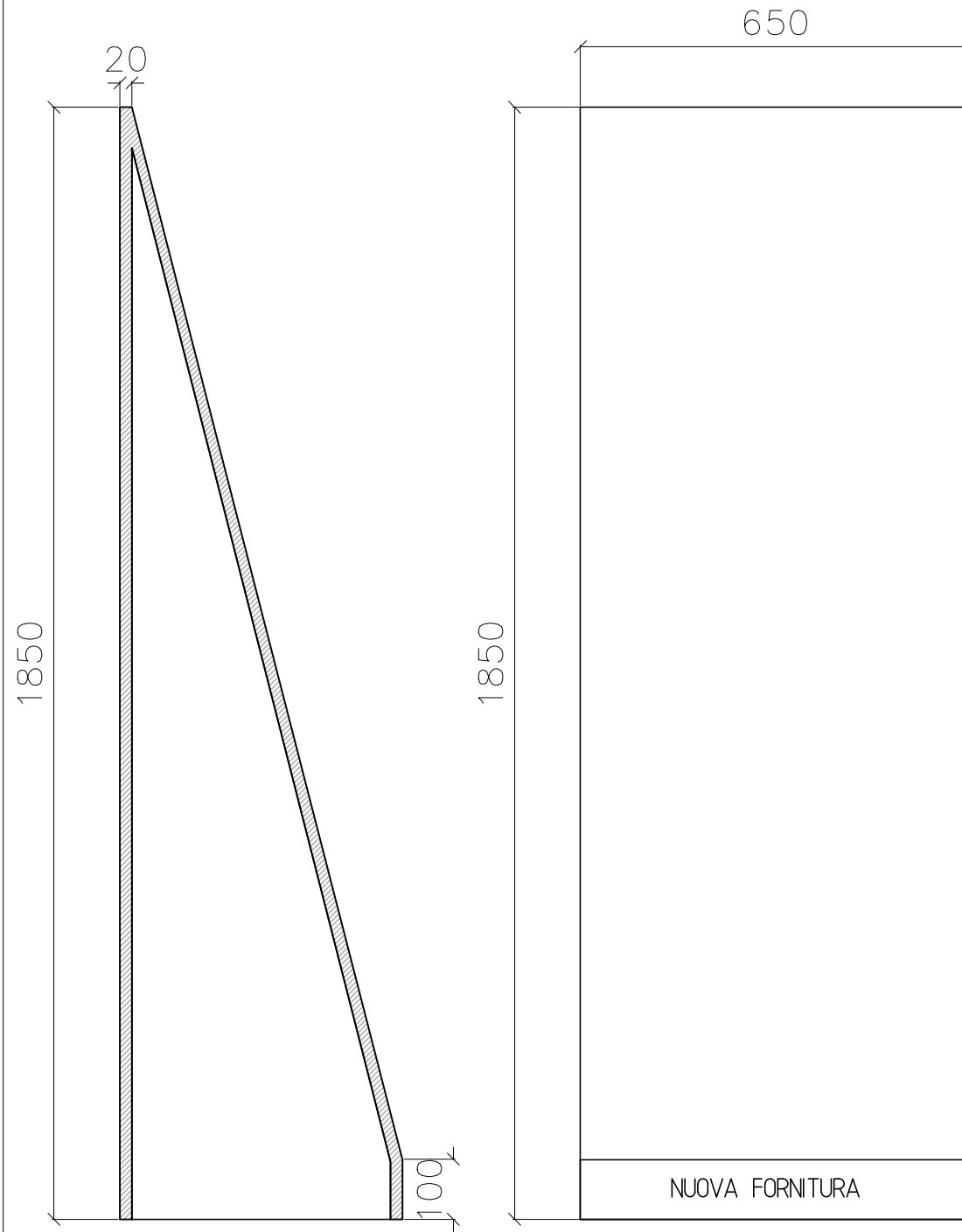

velcro 3M Dual Lock
SJ4507 inserito
tra i cristalli



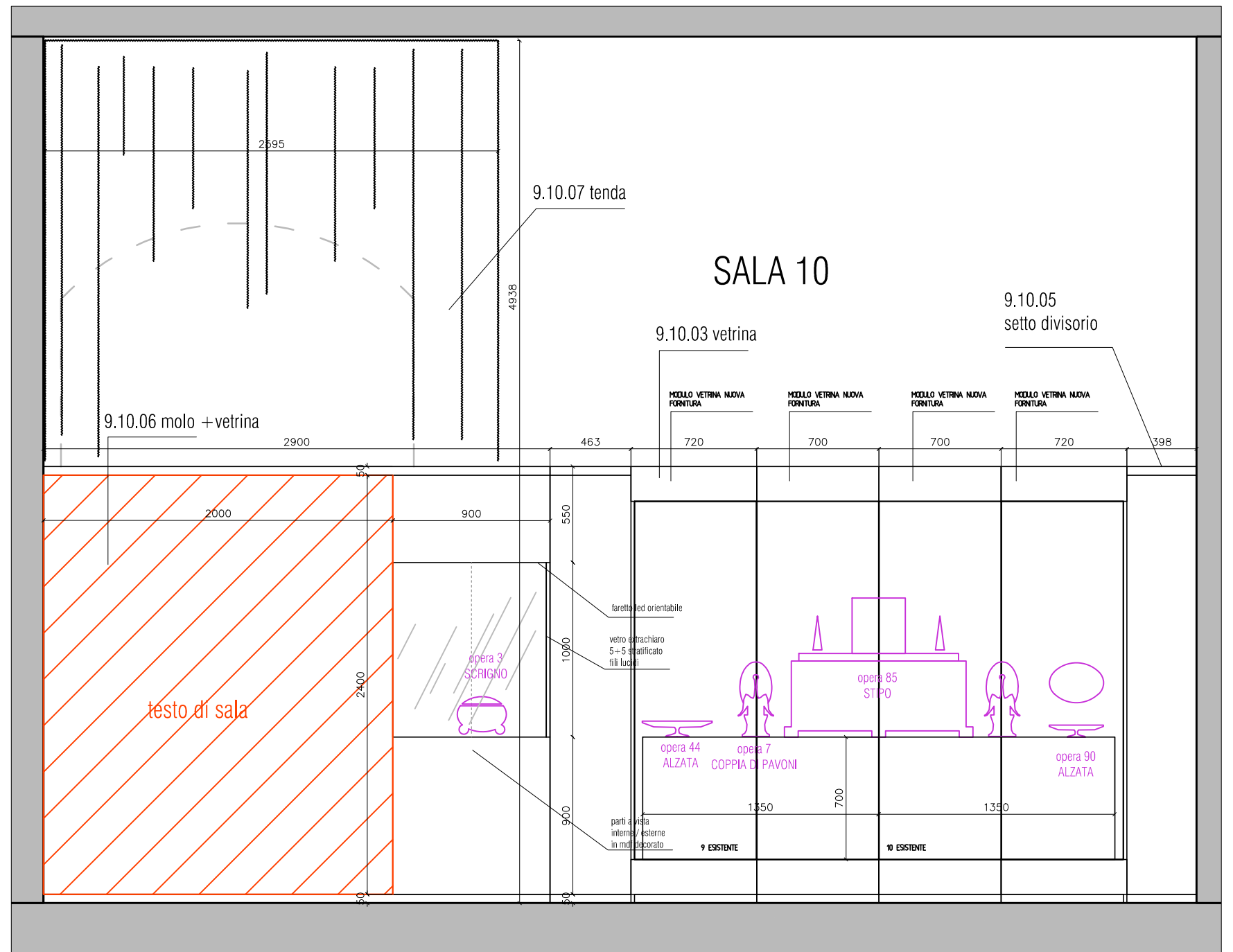
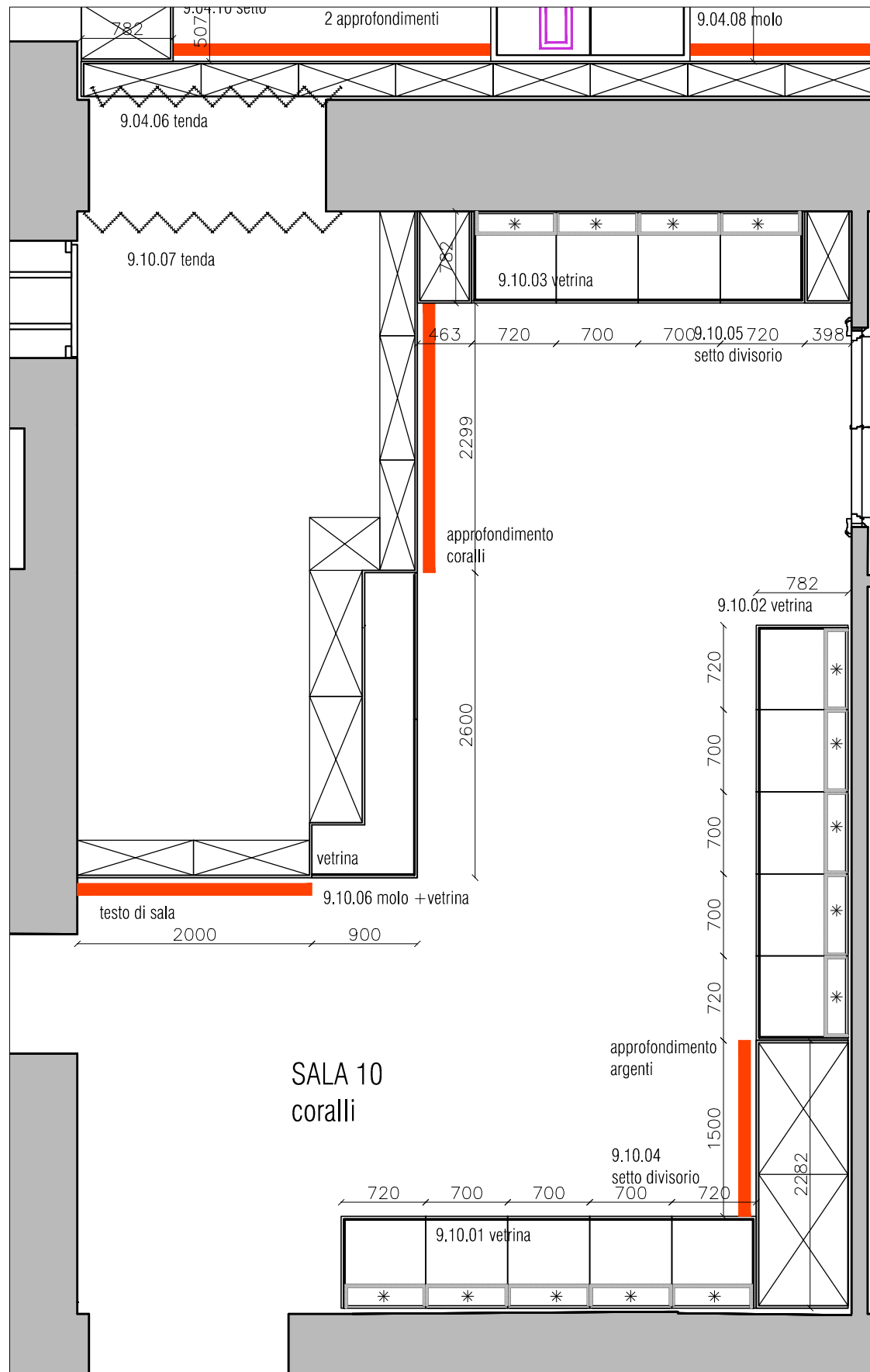

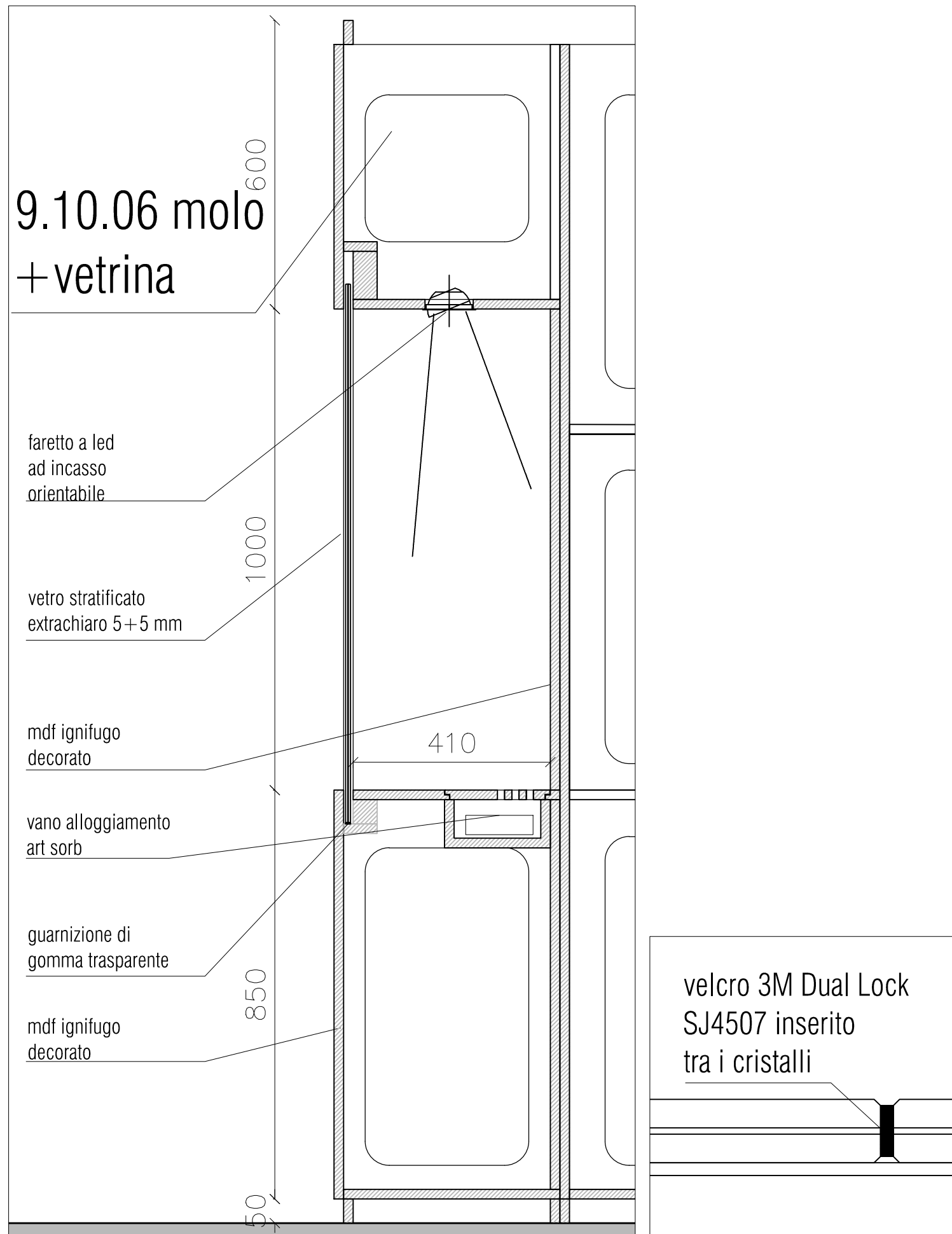

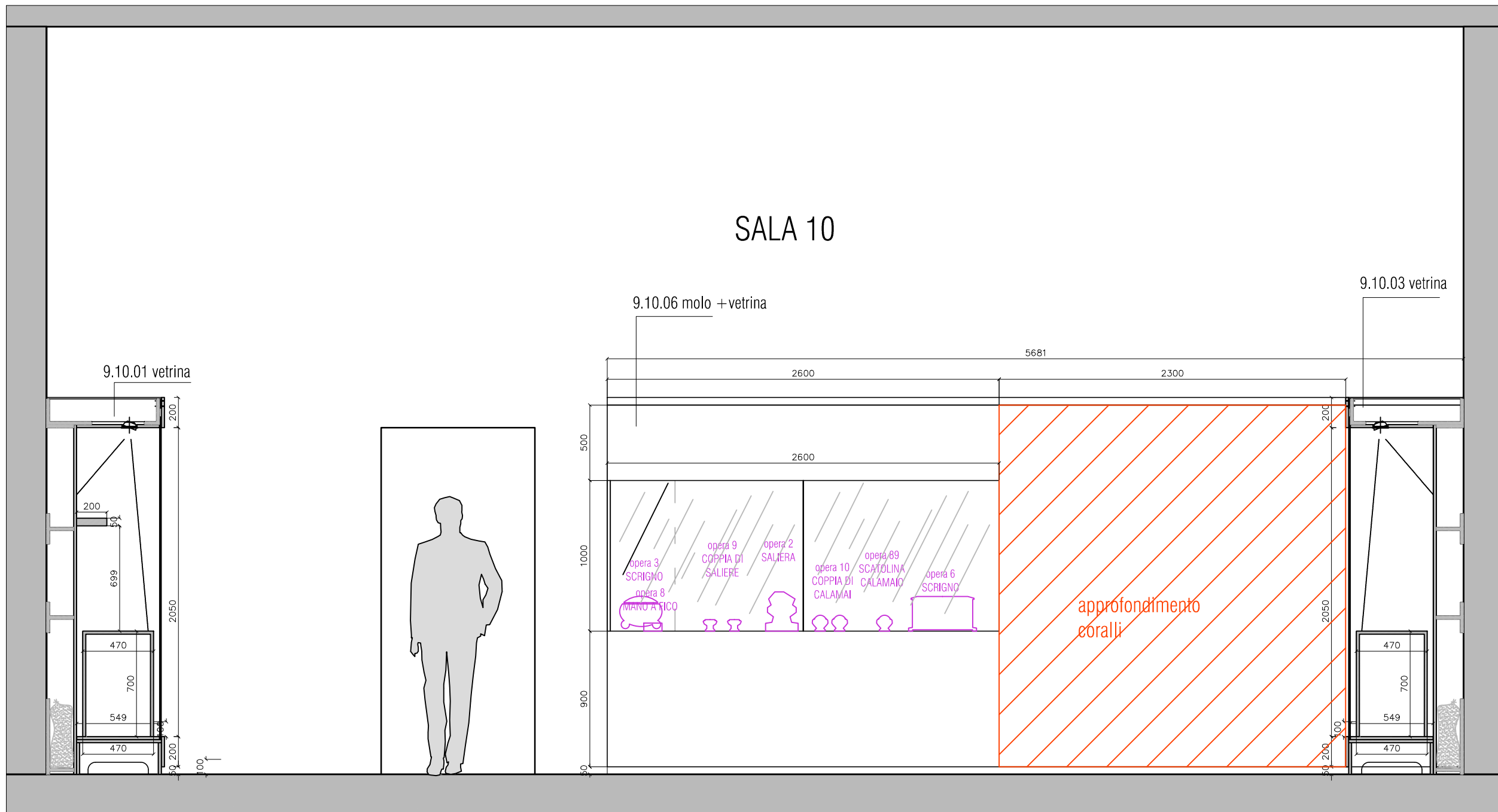

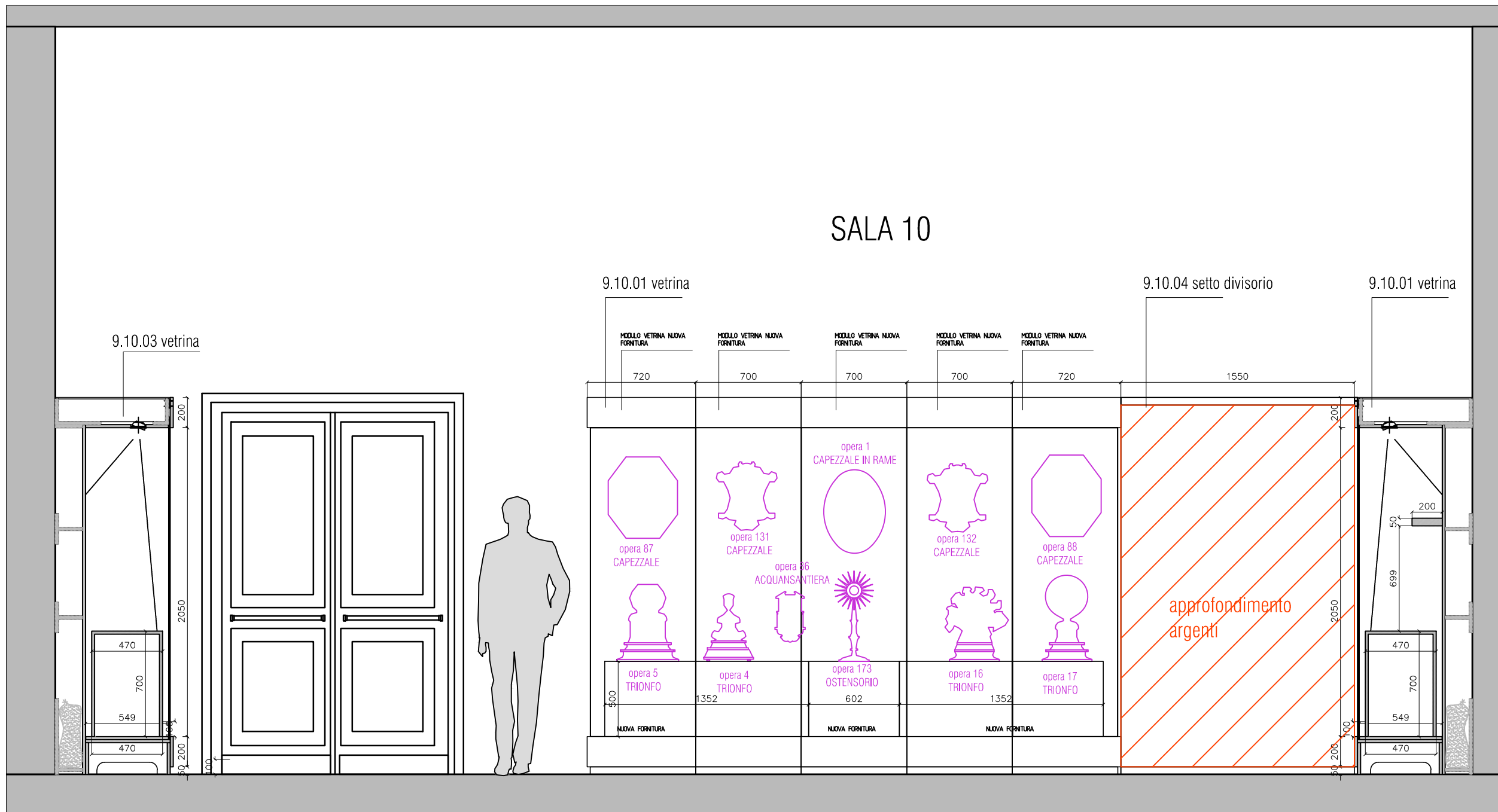

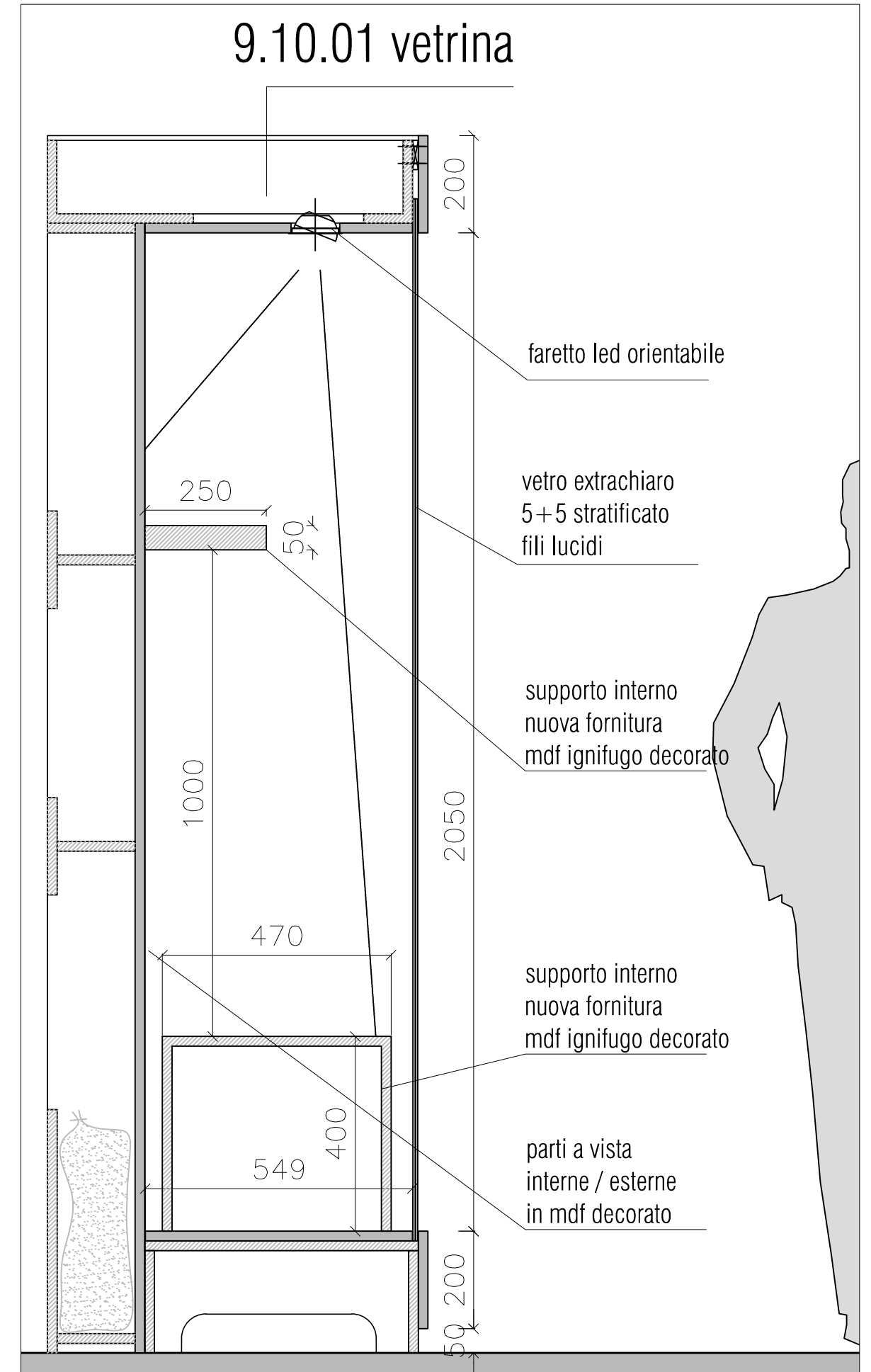
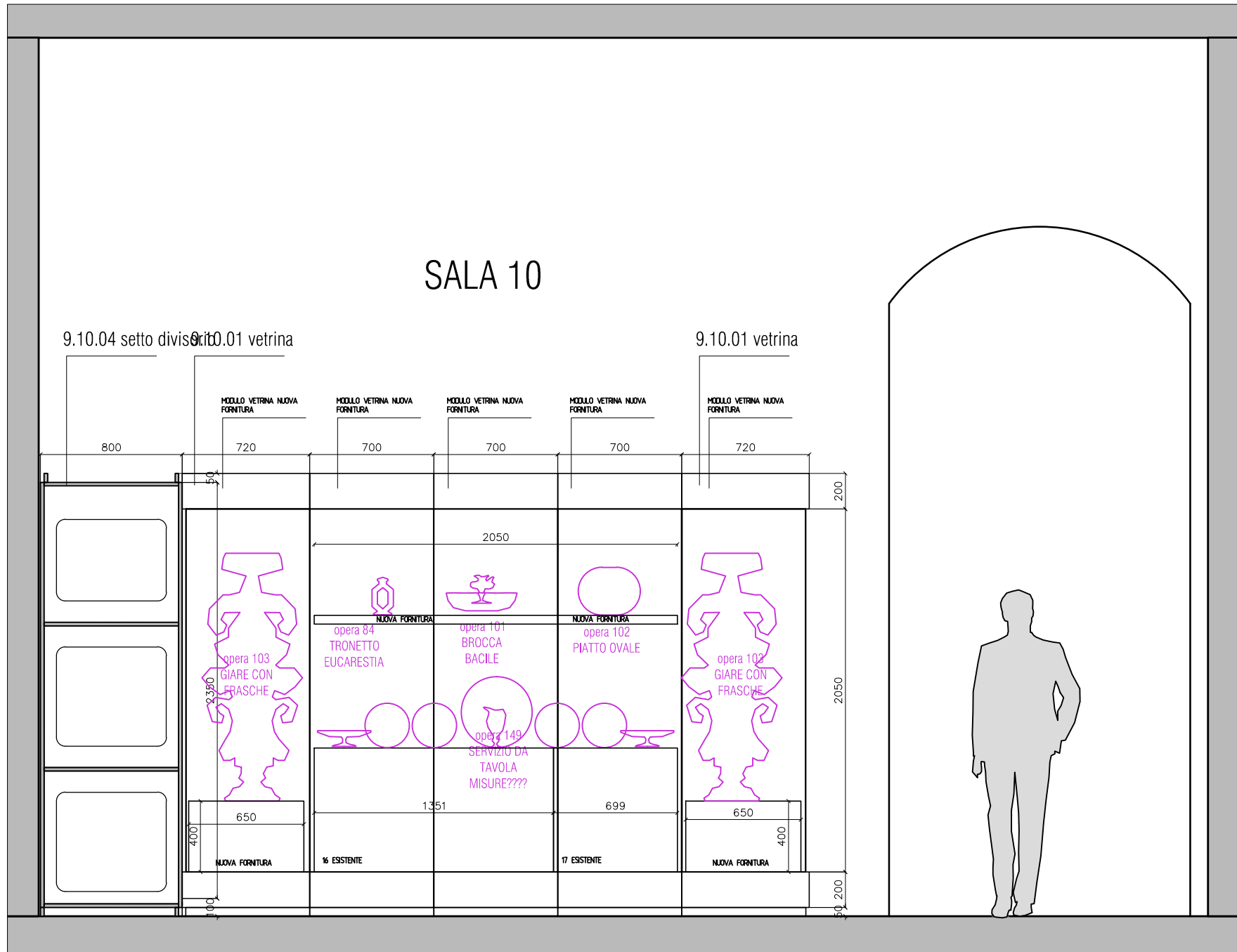

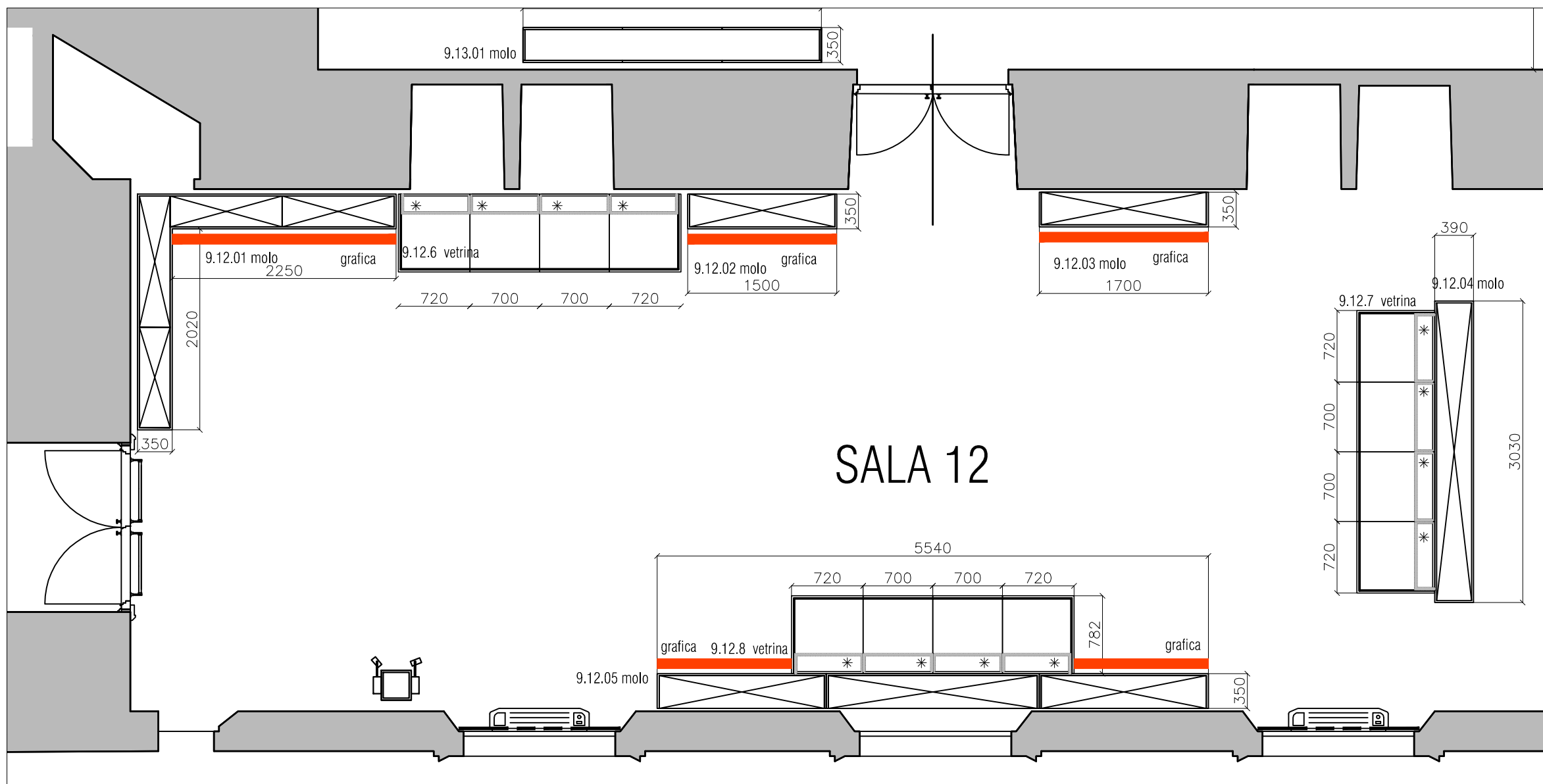

9.12.01 molo nuova fornitura

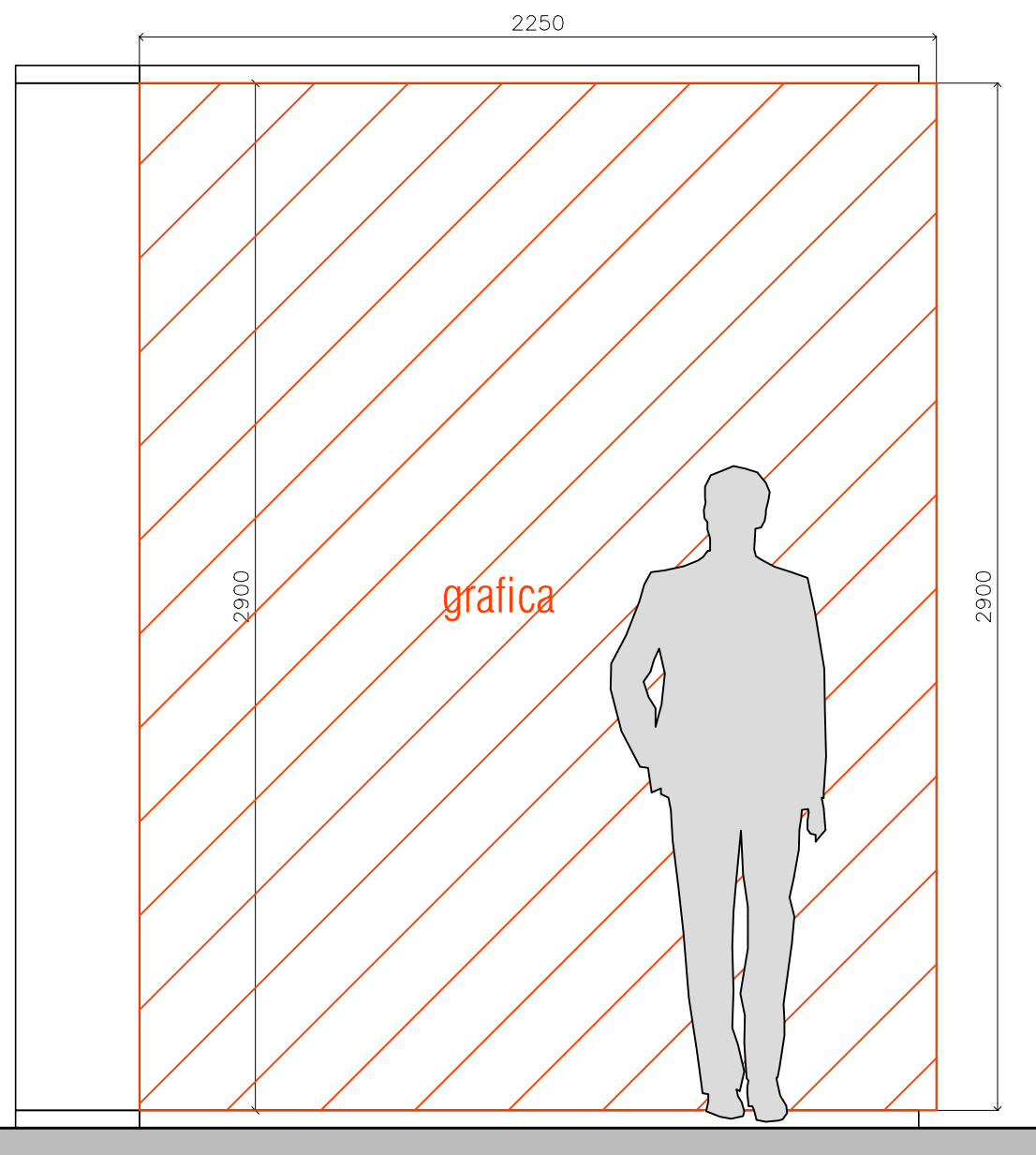

9.12.06 vetrina

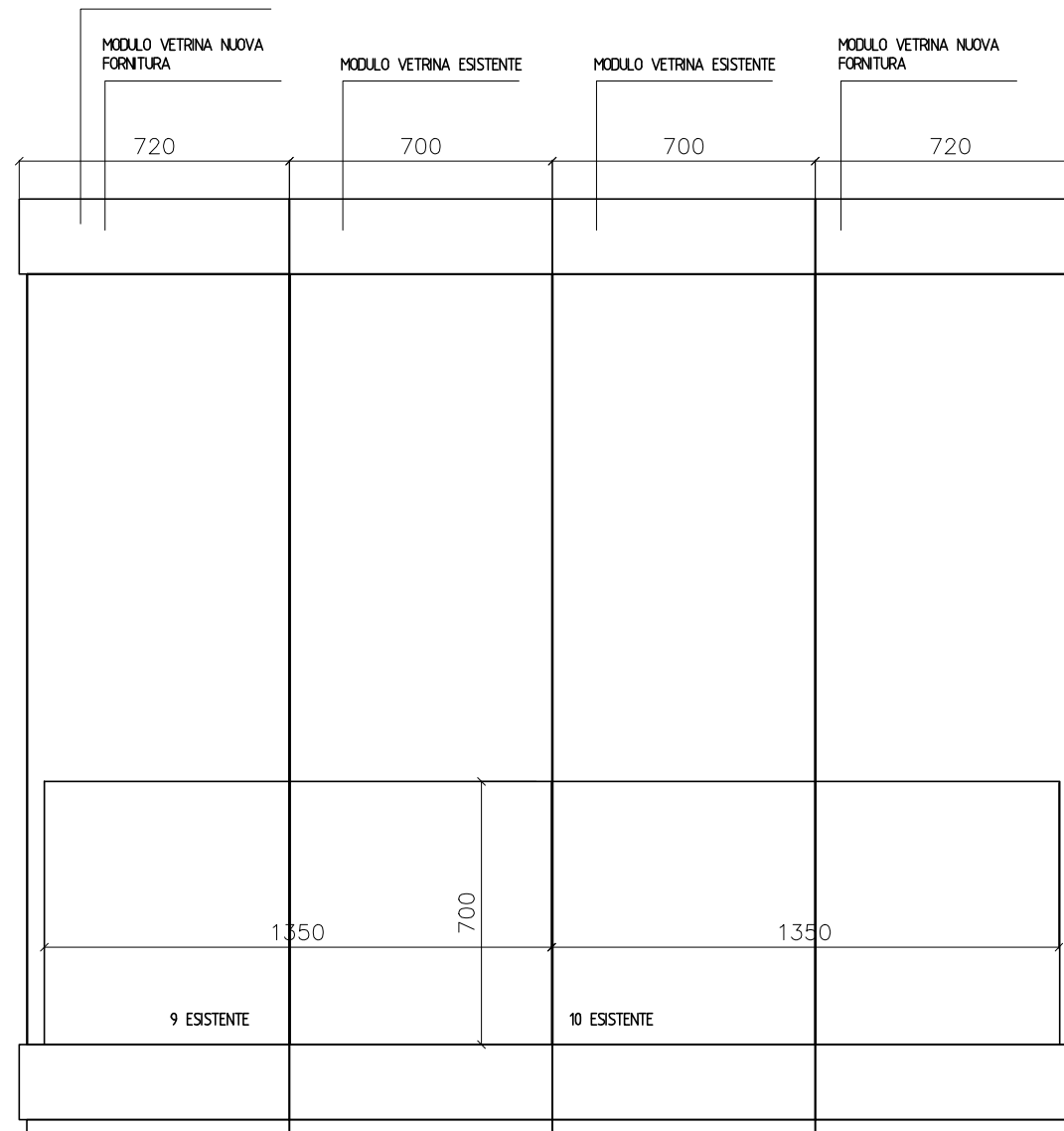

9.12.06 vetrina

