



La Venaria Reale
CONSORZIO DI VALORIZZAZIONE CULTURALE

**PROGETTO DI ALLESTIMENTO DELLA MOSTRA
"LE MERAVIGLIE DEGLI ZAR"**

PIANO PRIMO SALE DELLE ARTI

**OGGETTO:
ELABORATI GRAFICI**

E.G.

RESPONSABILE DEL PROCEDIMENTO
Gianbeppe Colombano

PROGETTO DI ALLESTIMENTO: arch. Giovanni Tironi

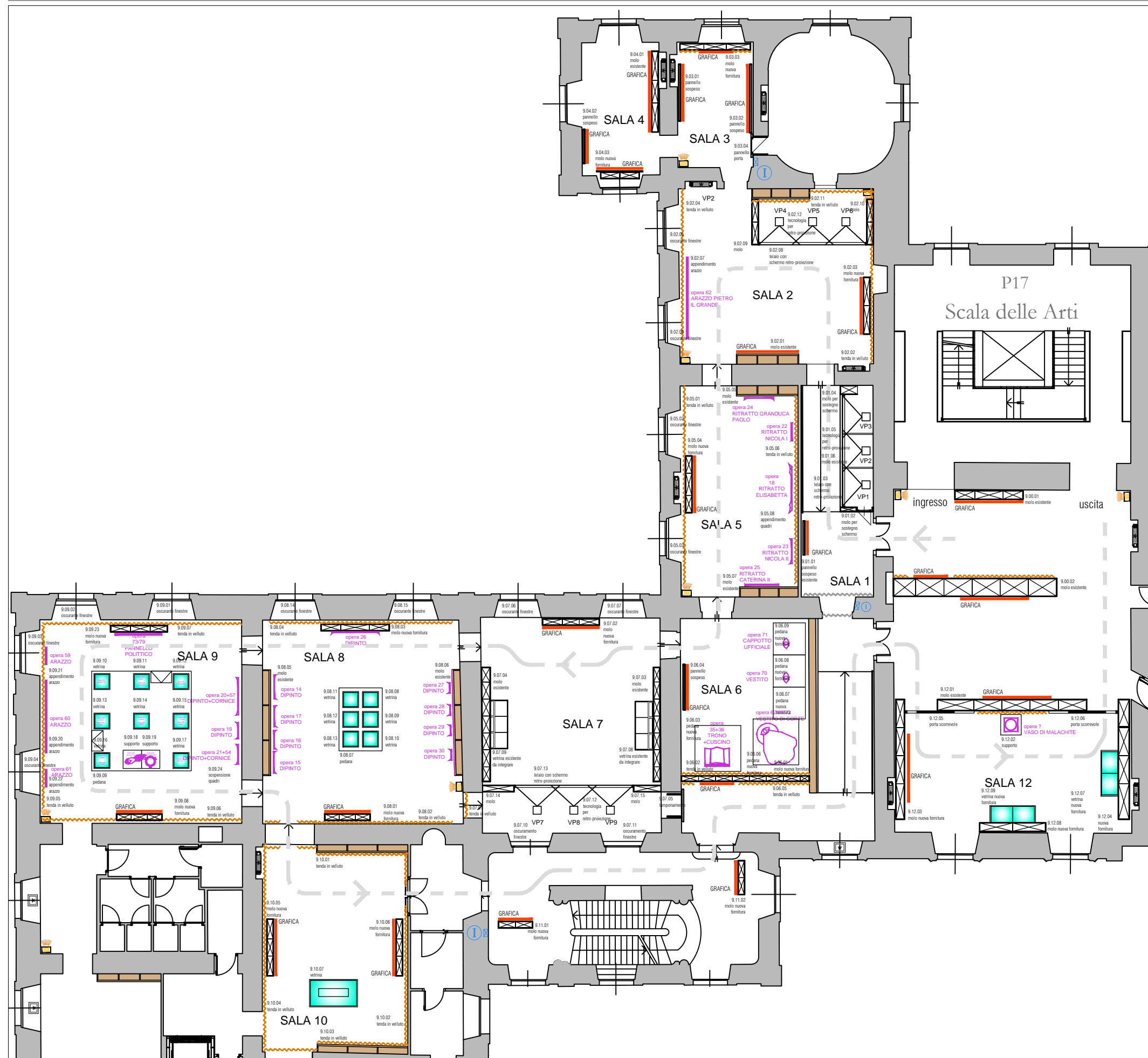

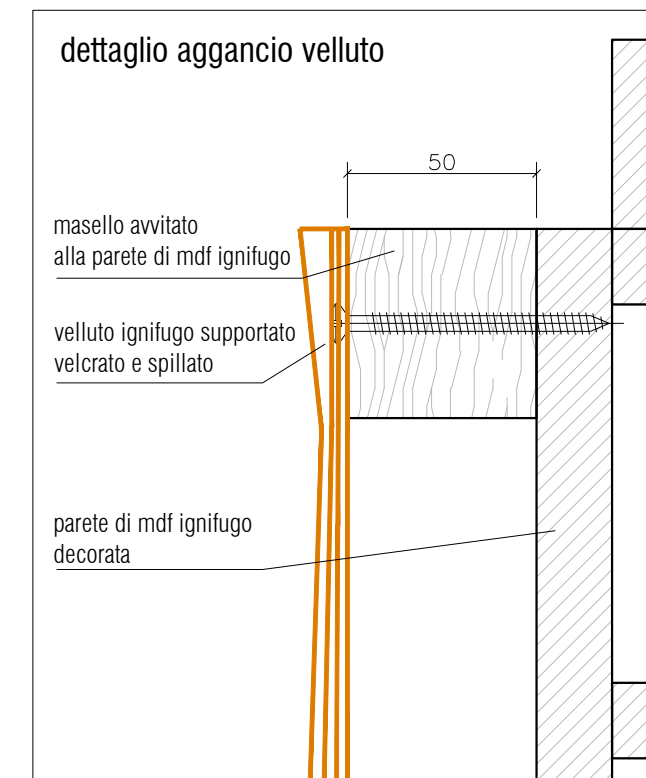
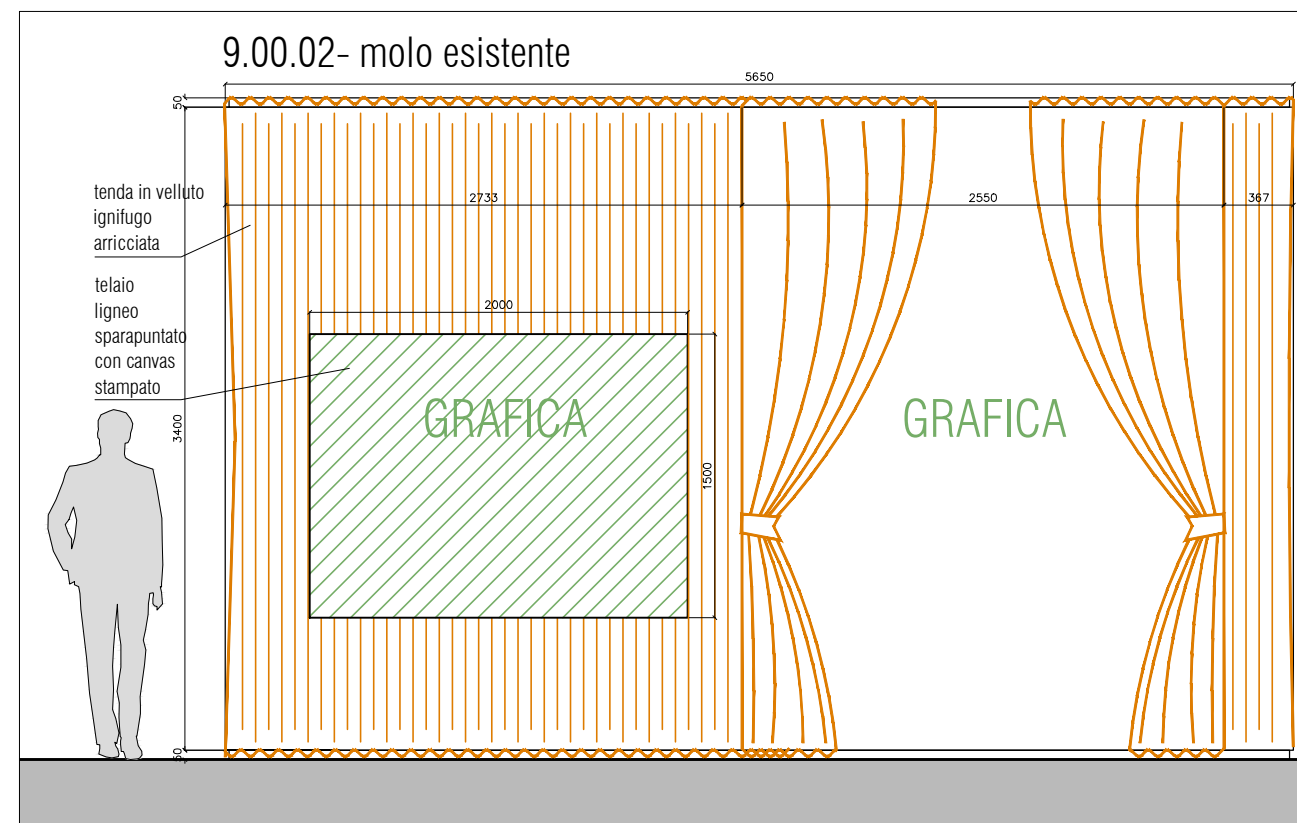
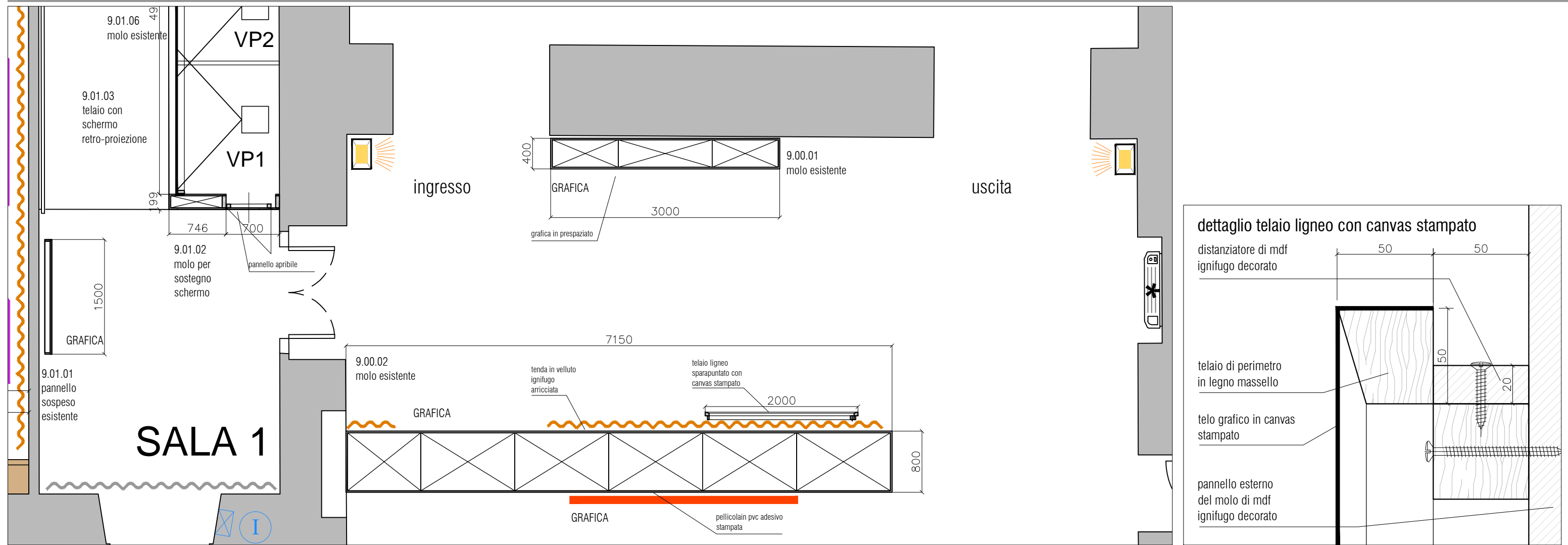

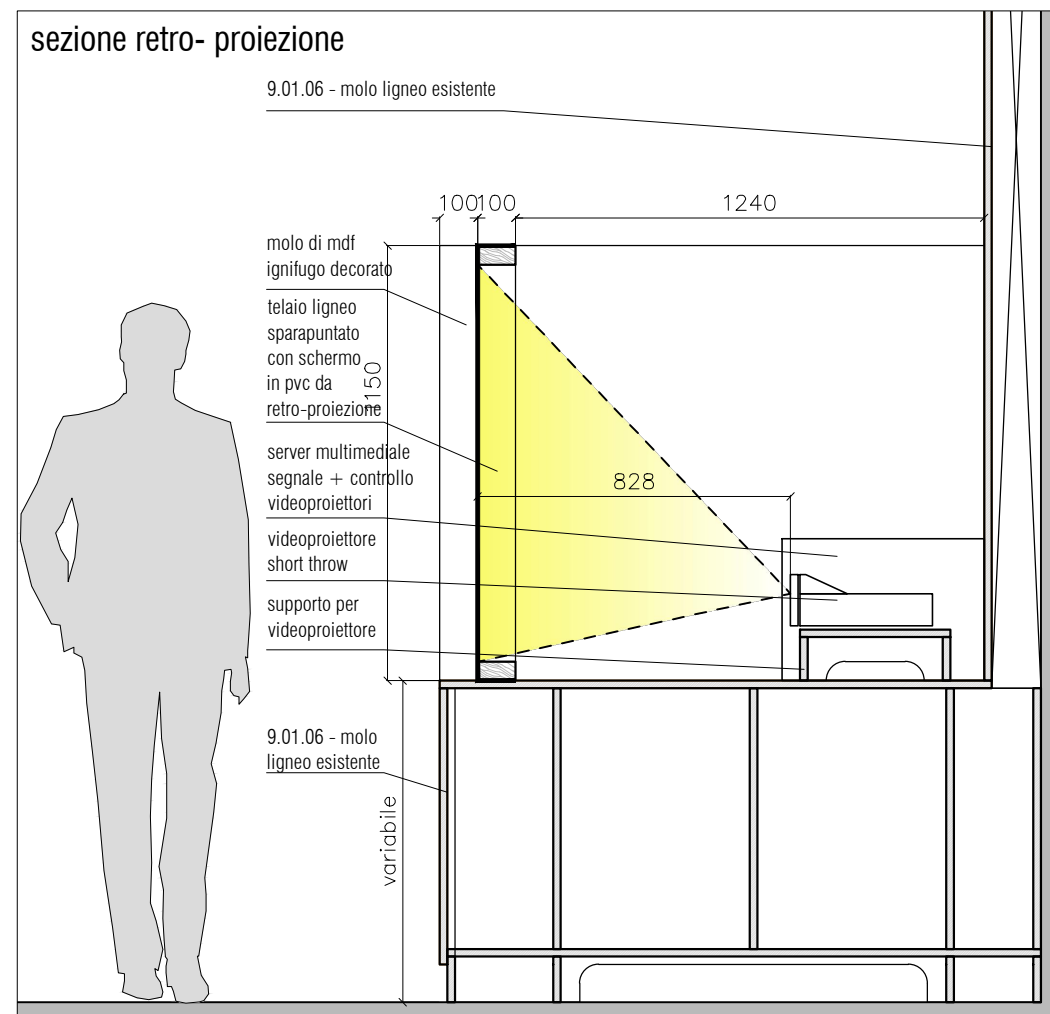
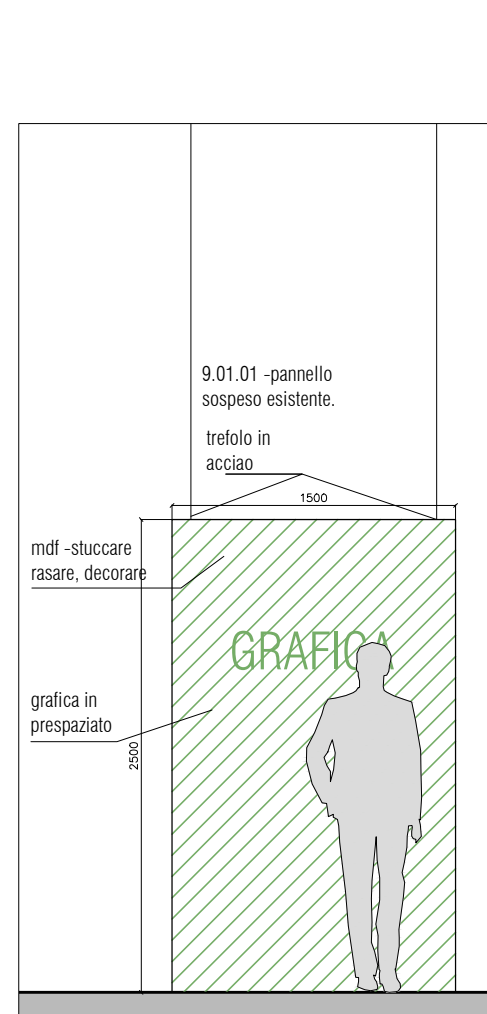
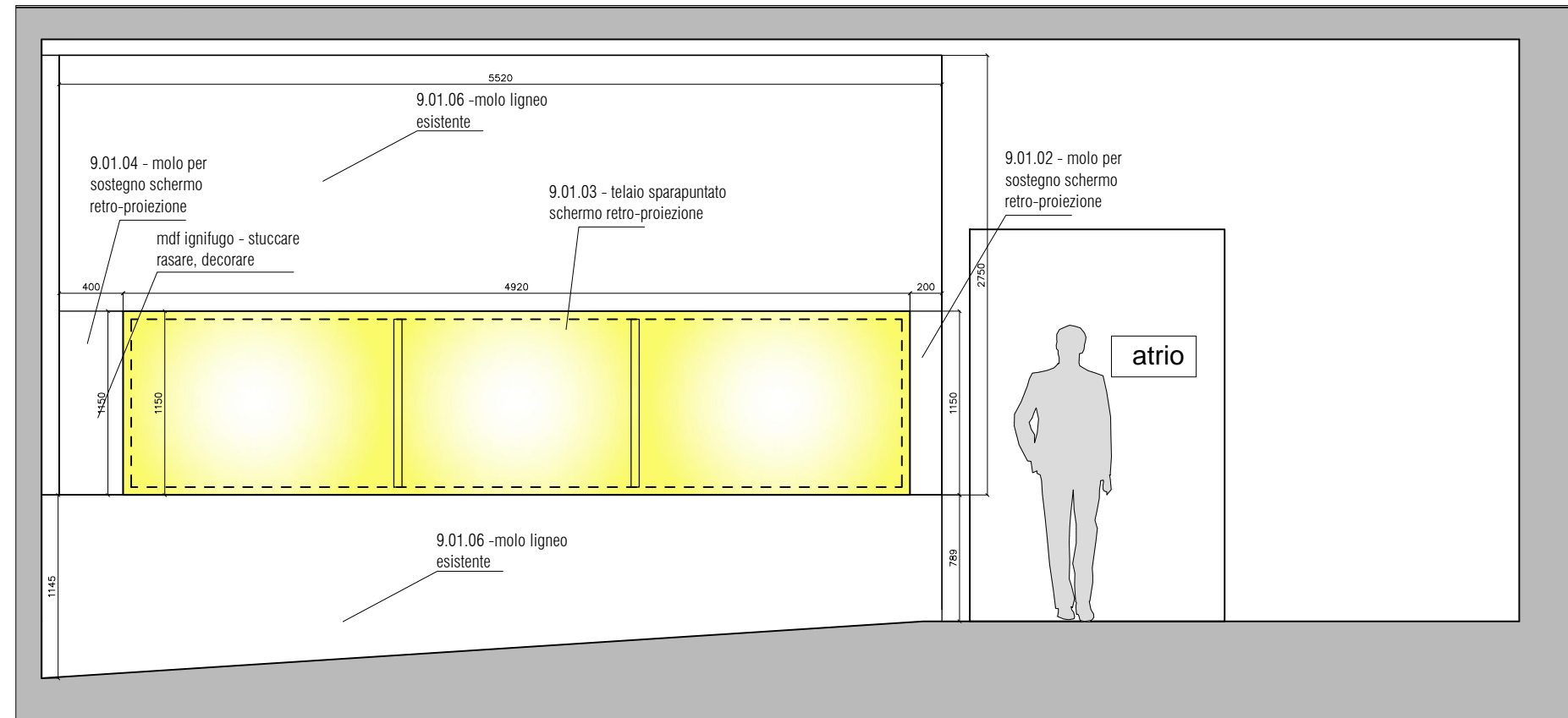
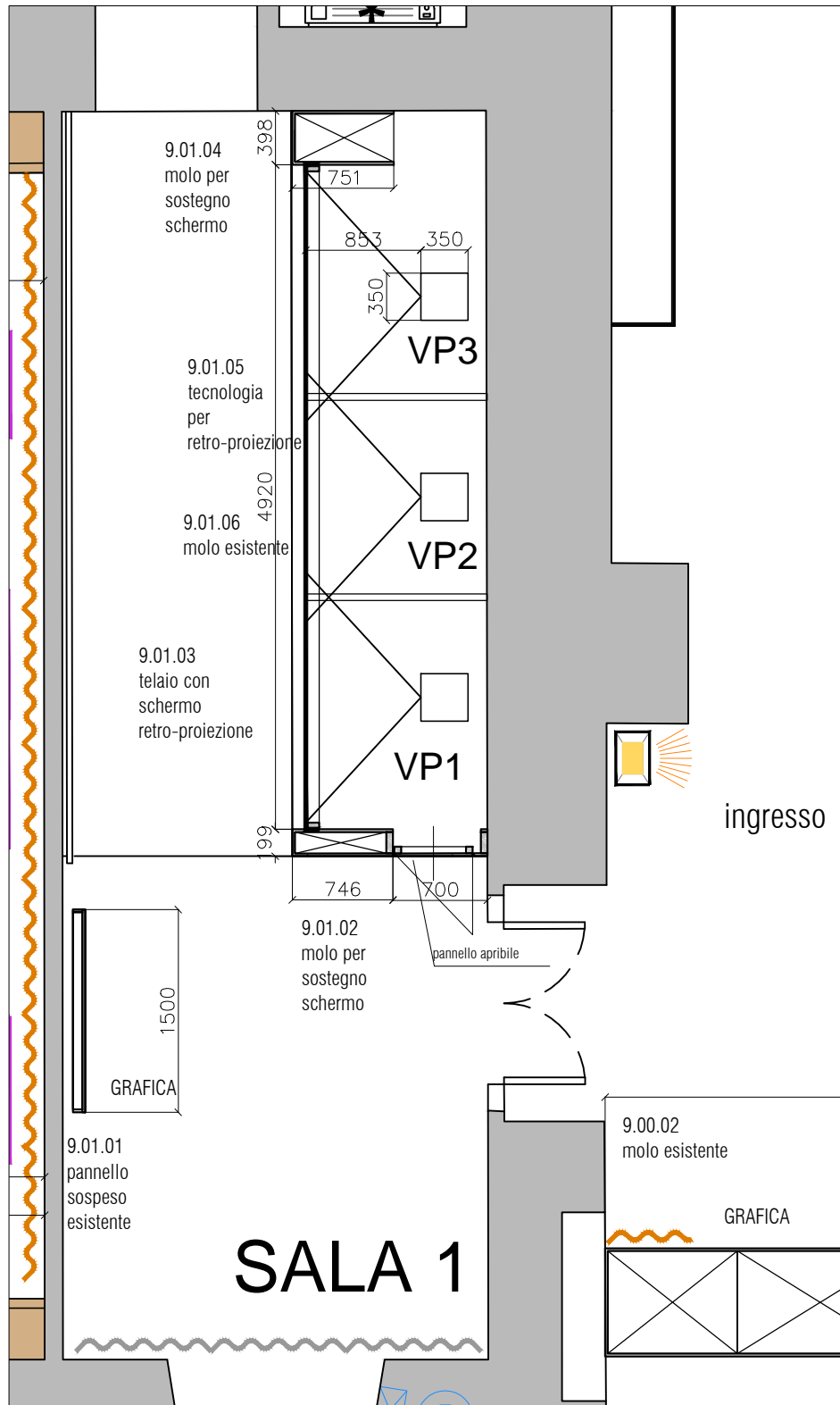

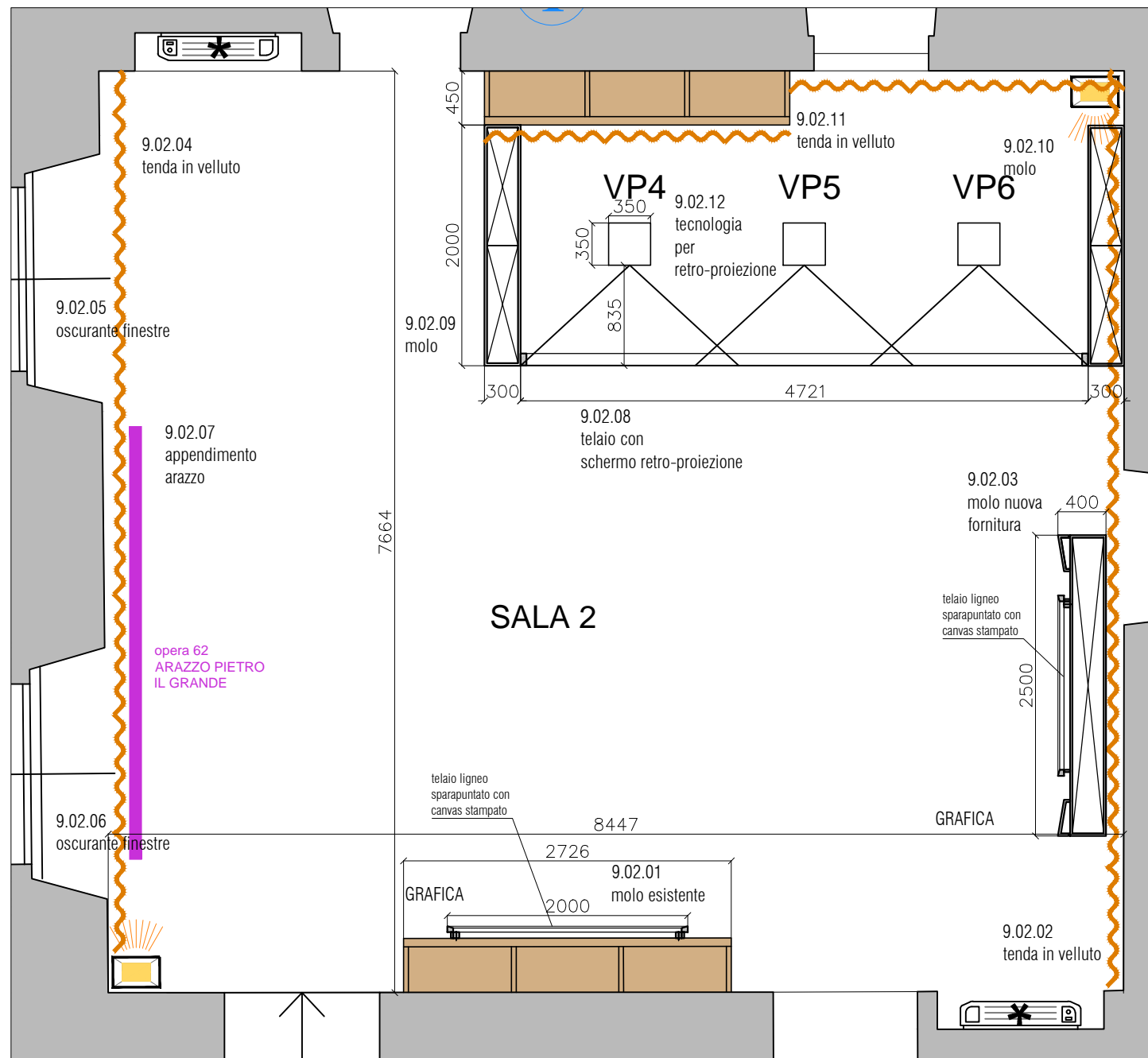

sezione retro- proiezione

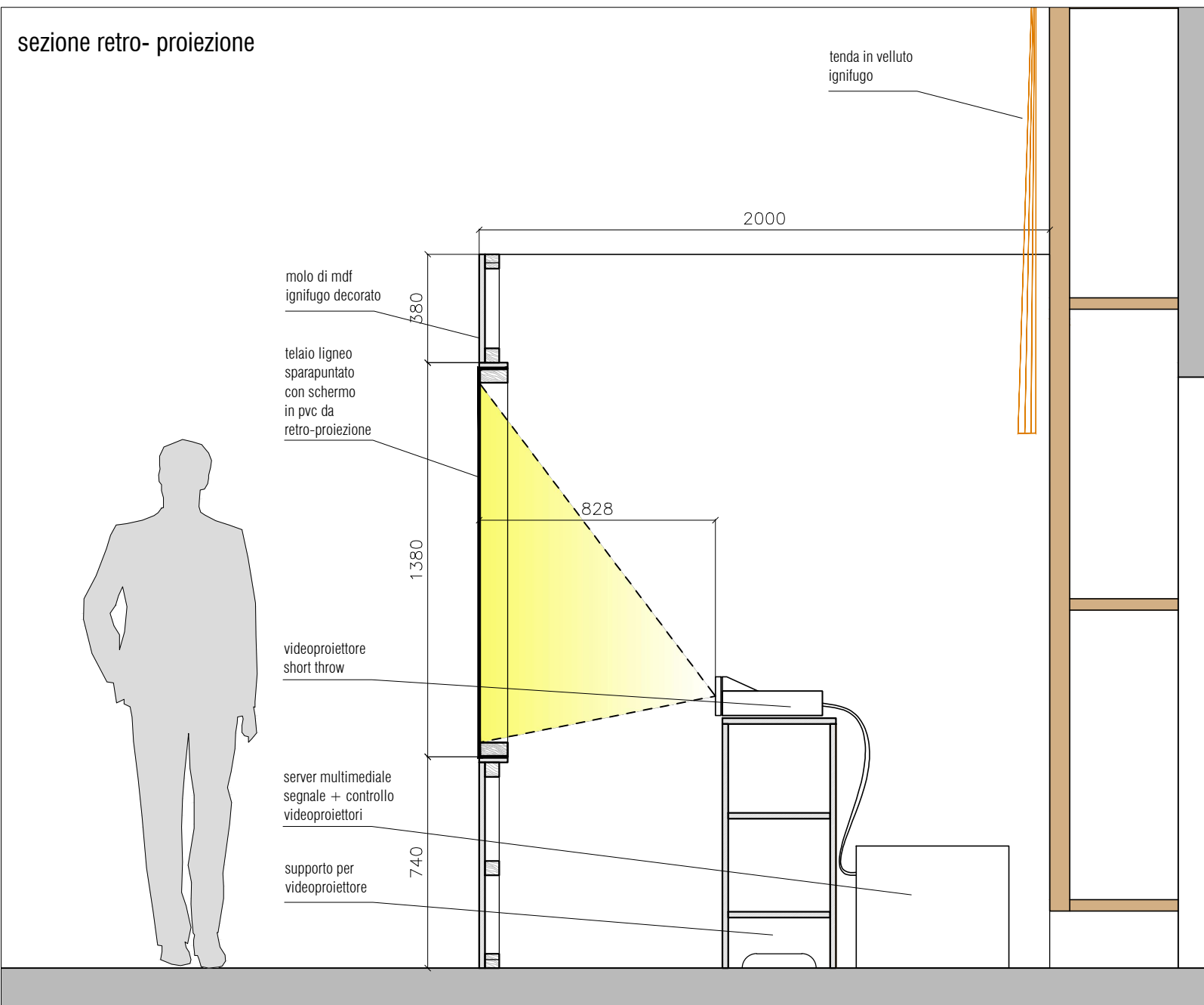

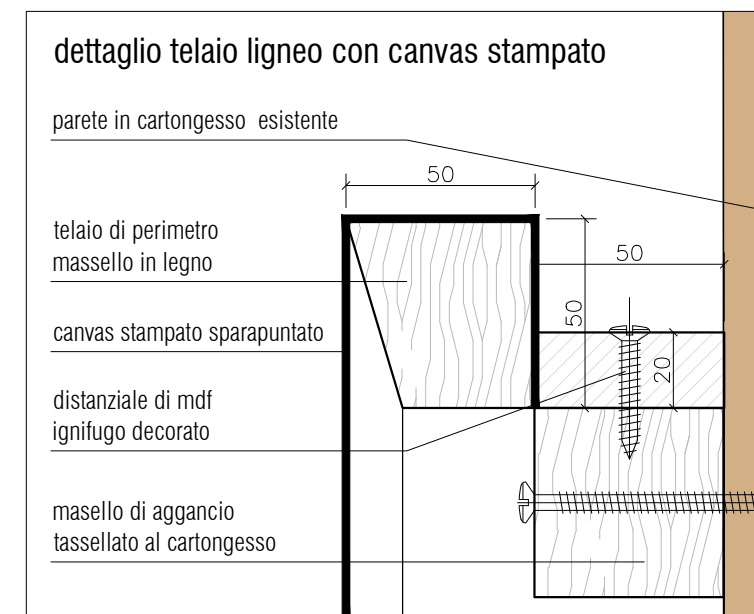
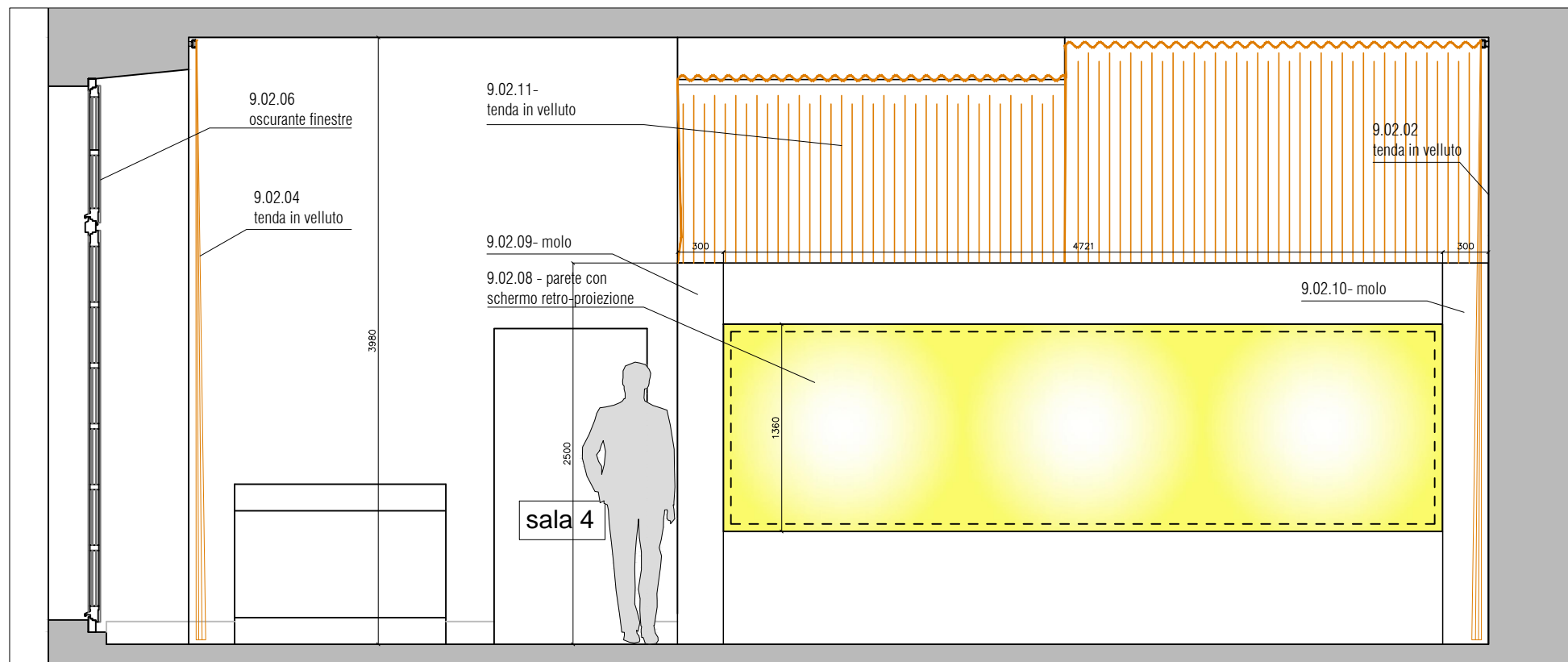
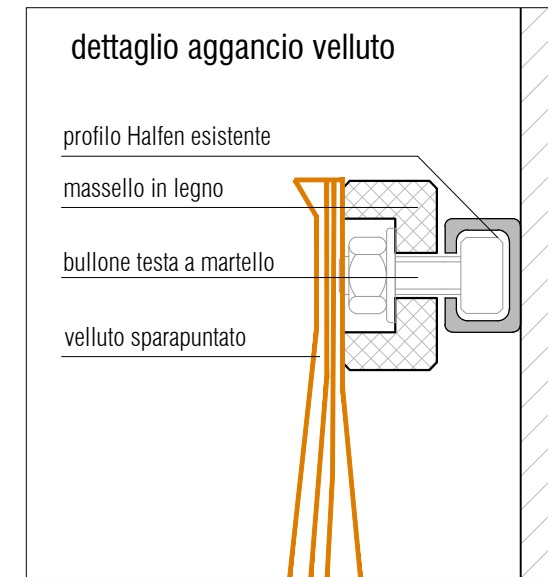
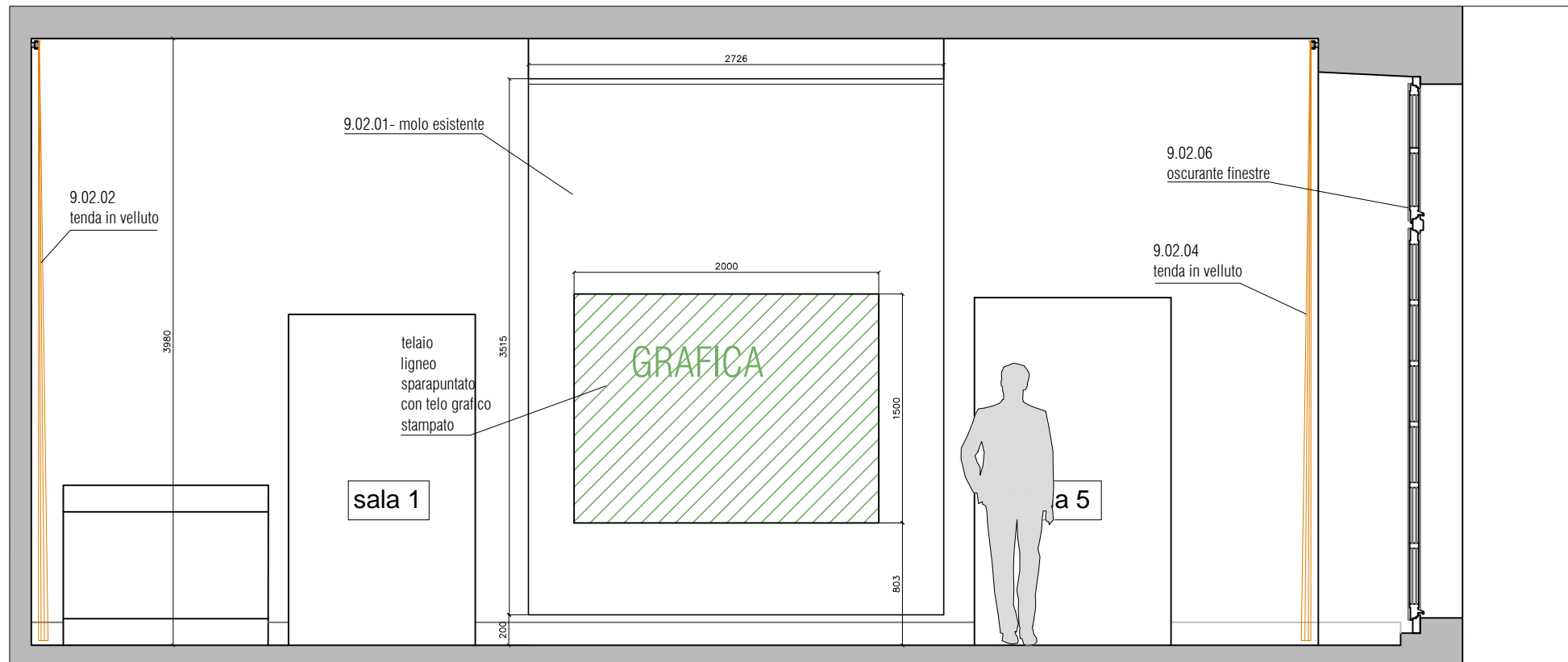

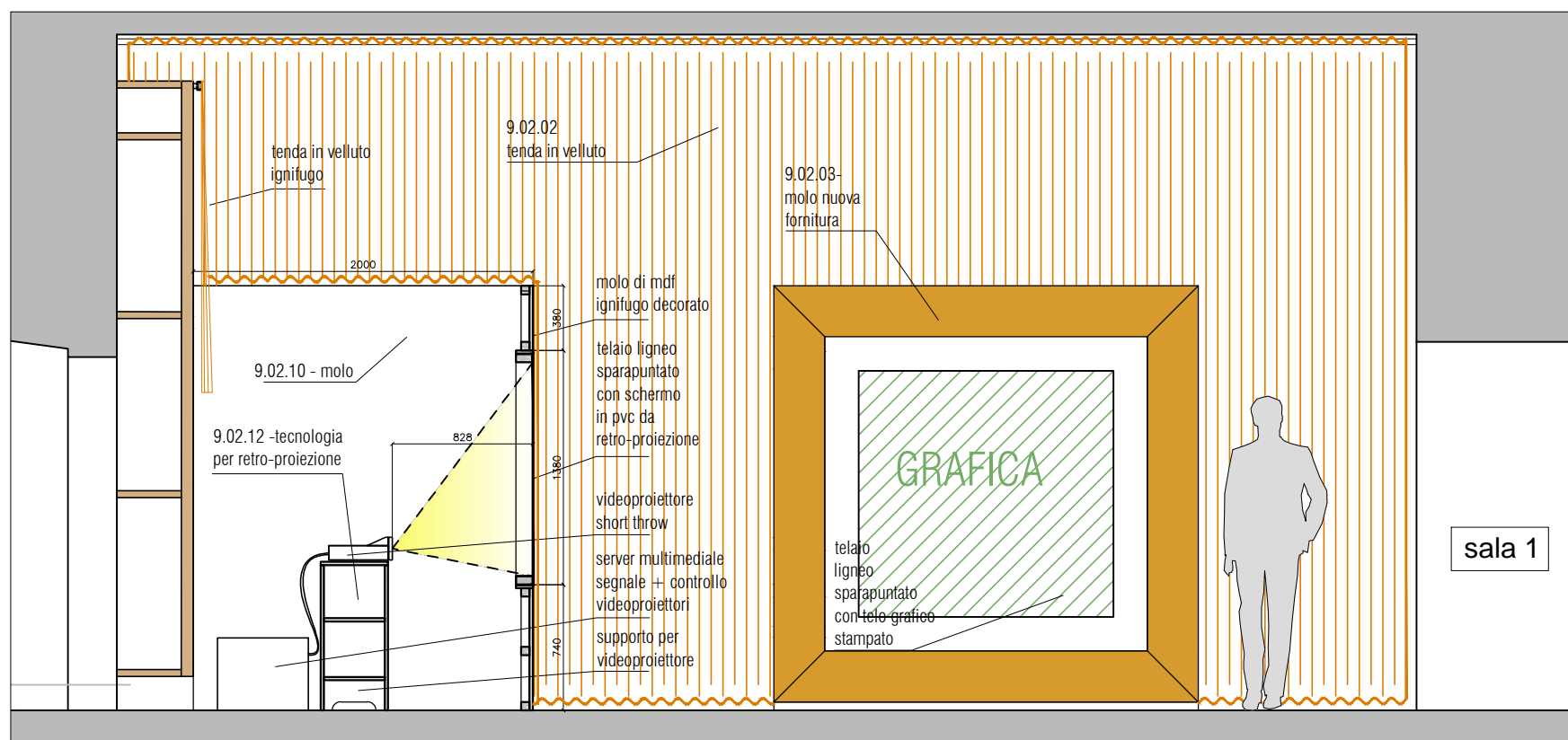
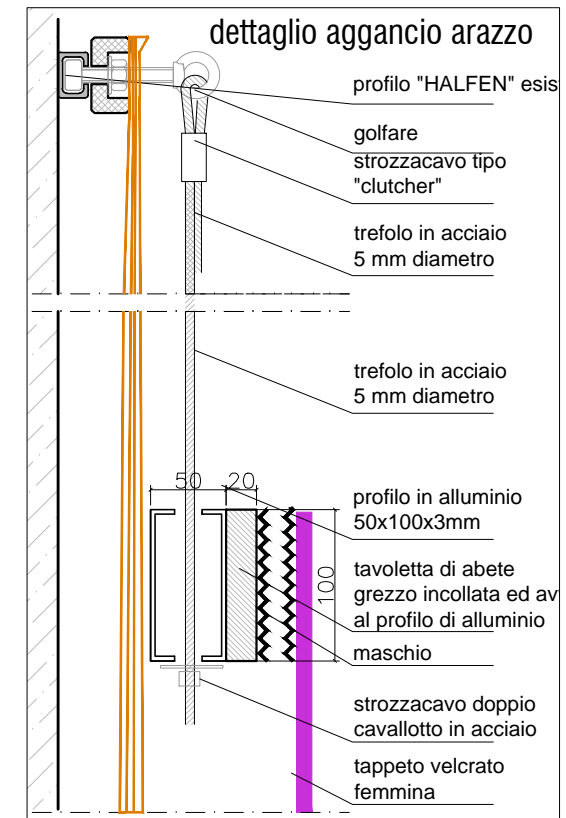
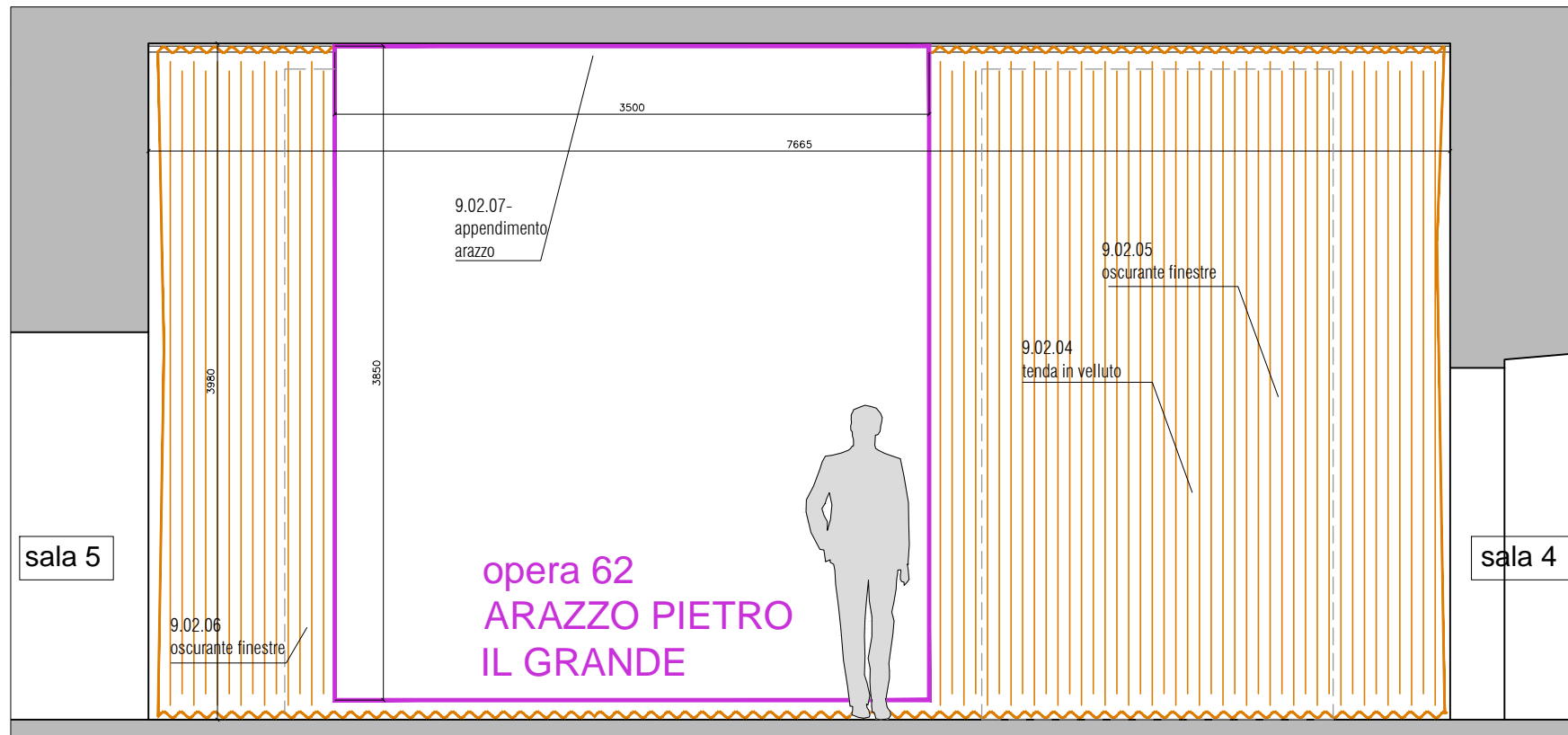

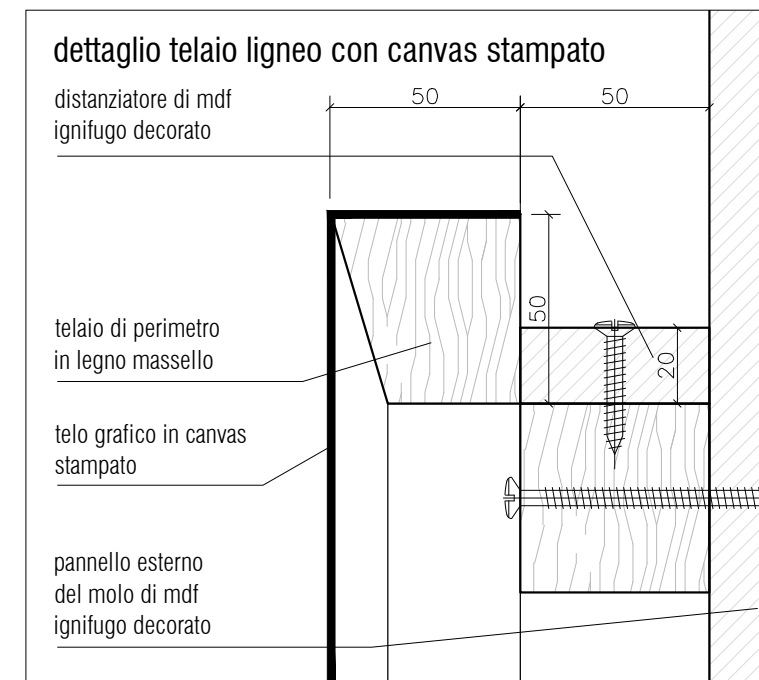
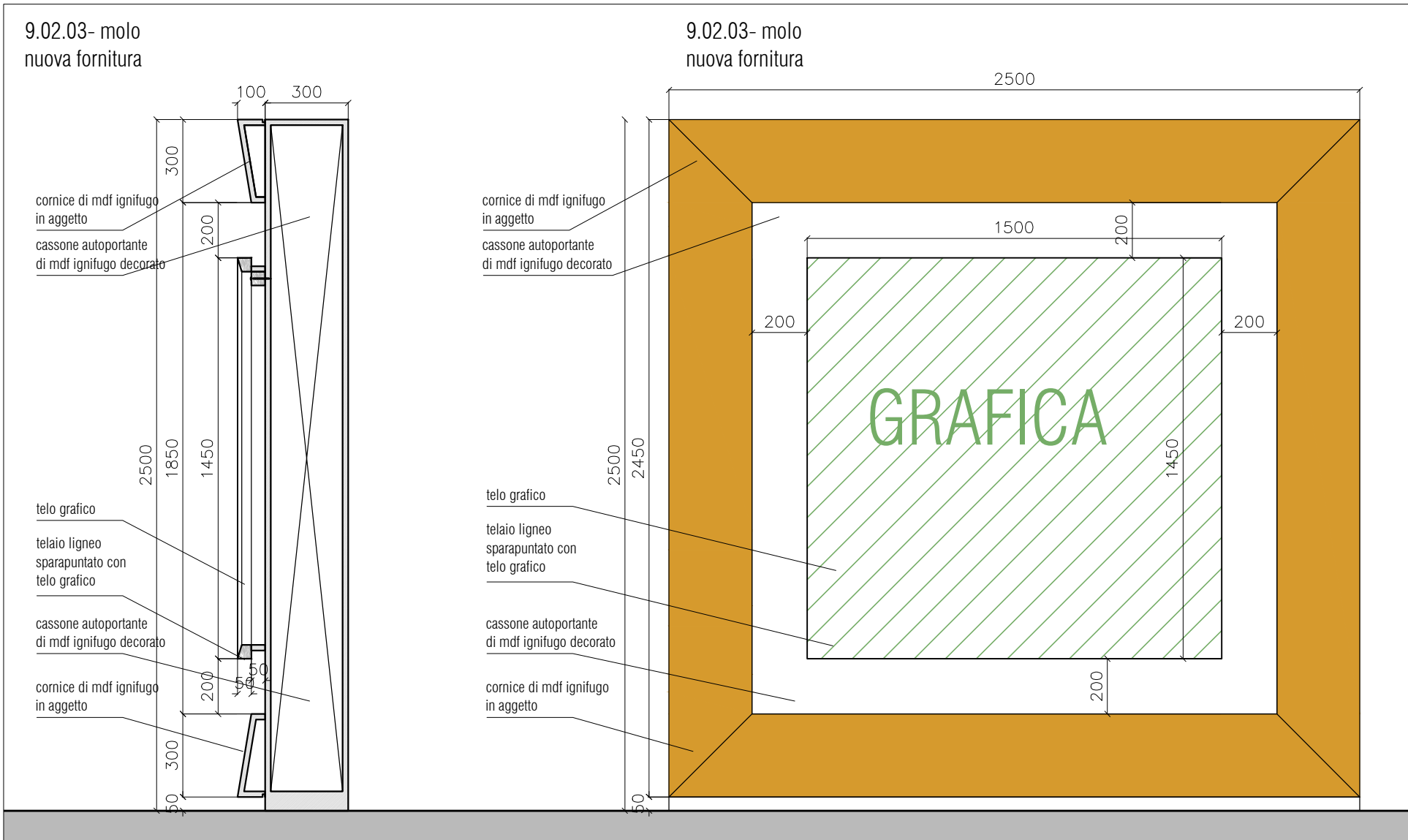

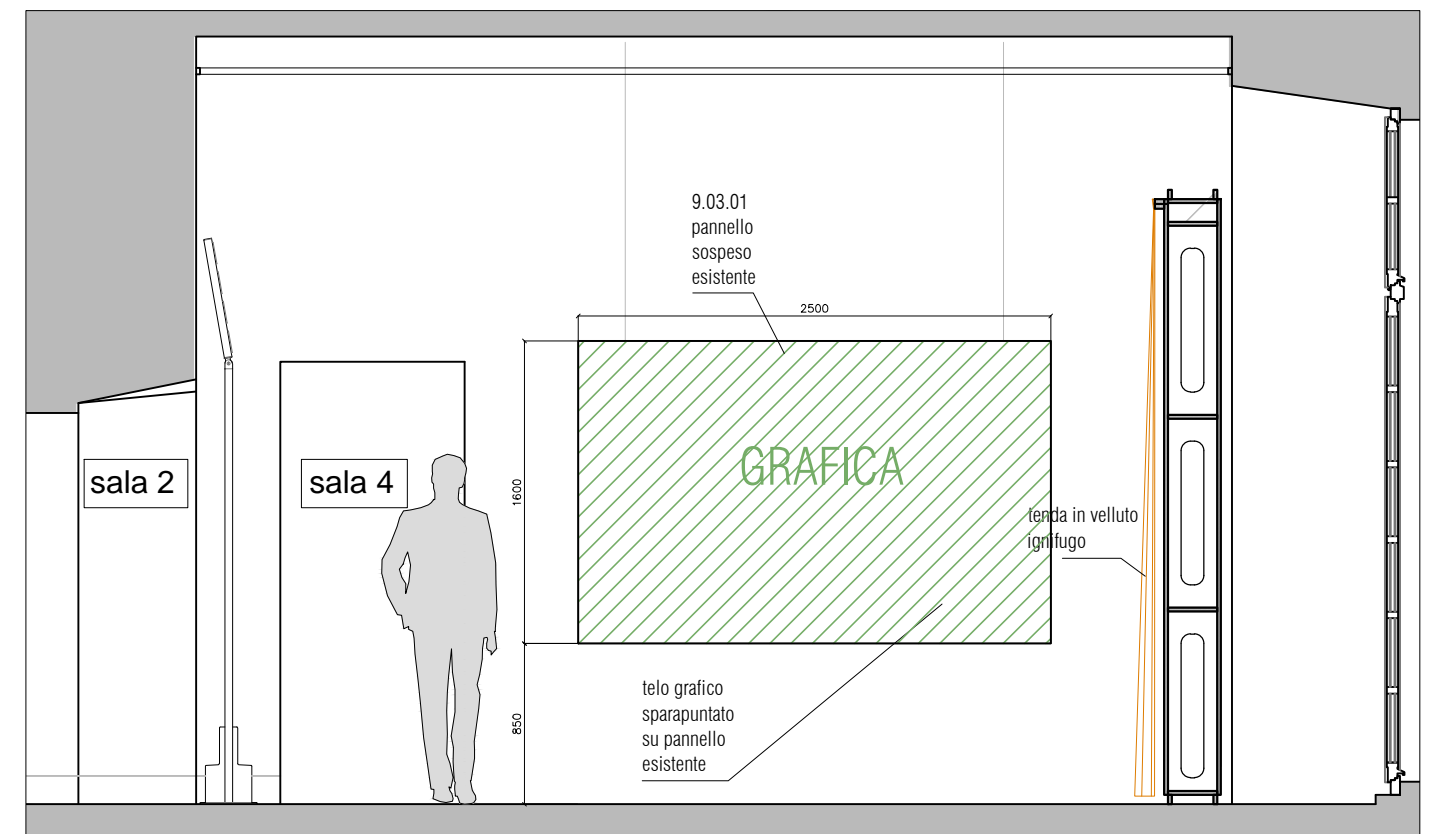
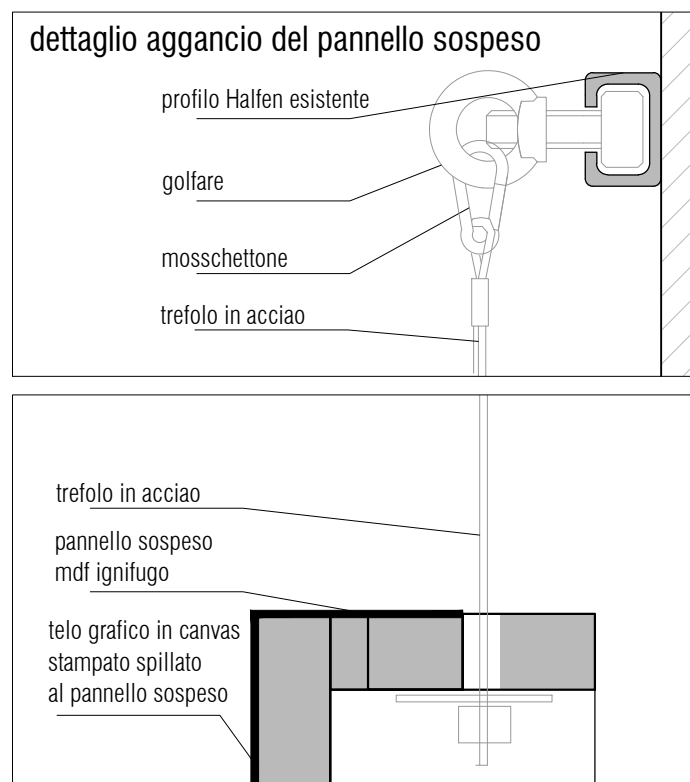
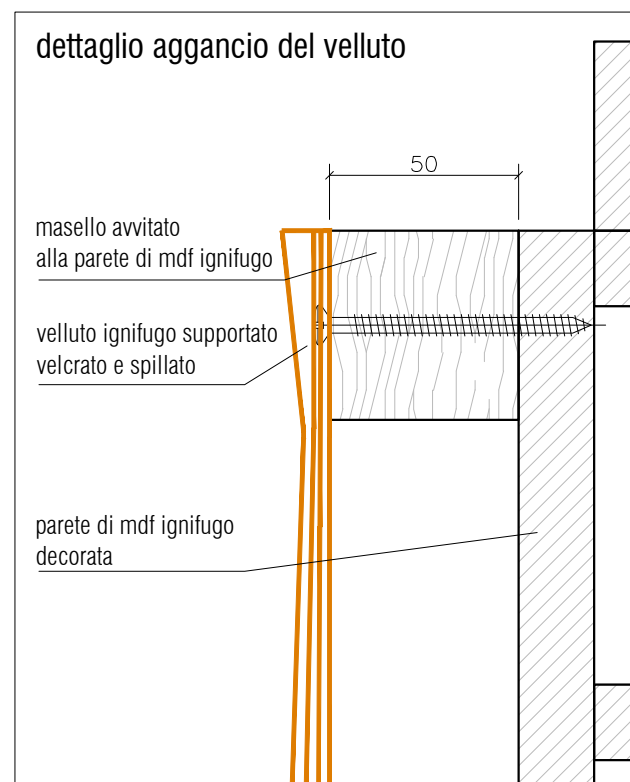
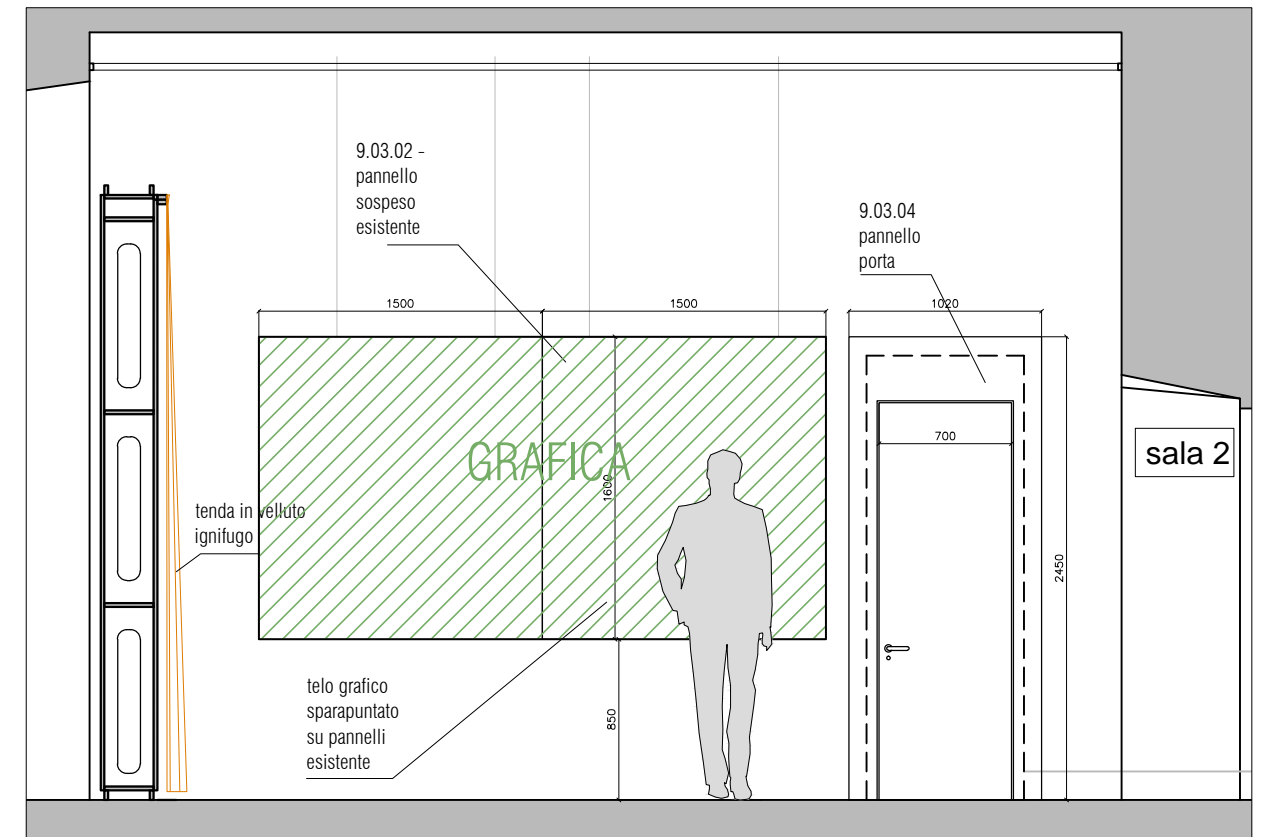
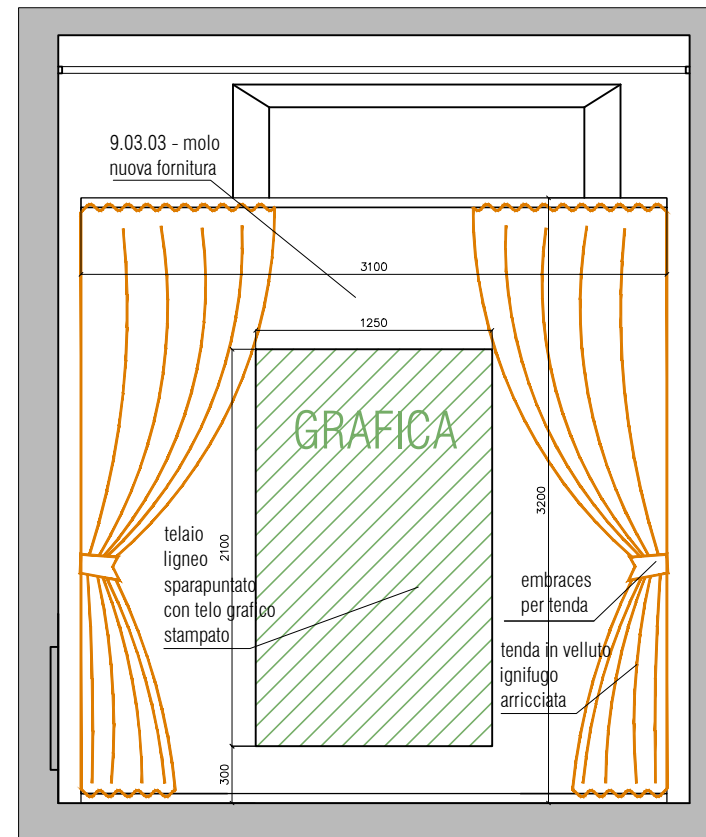
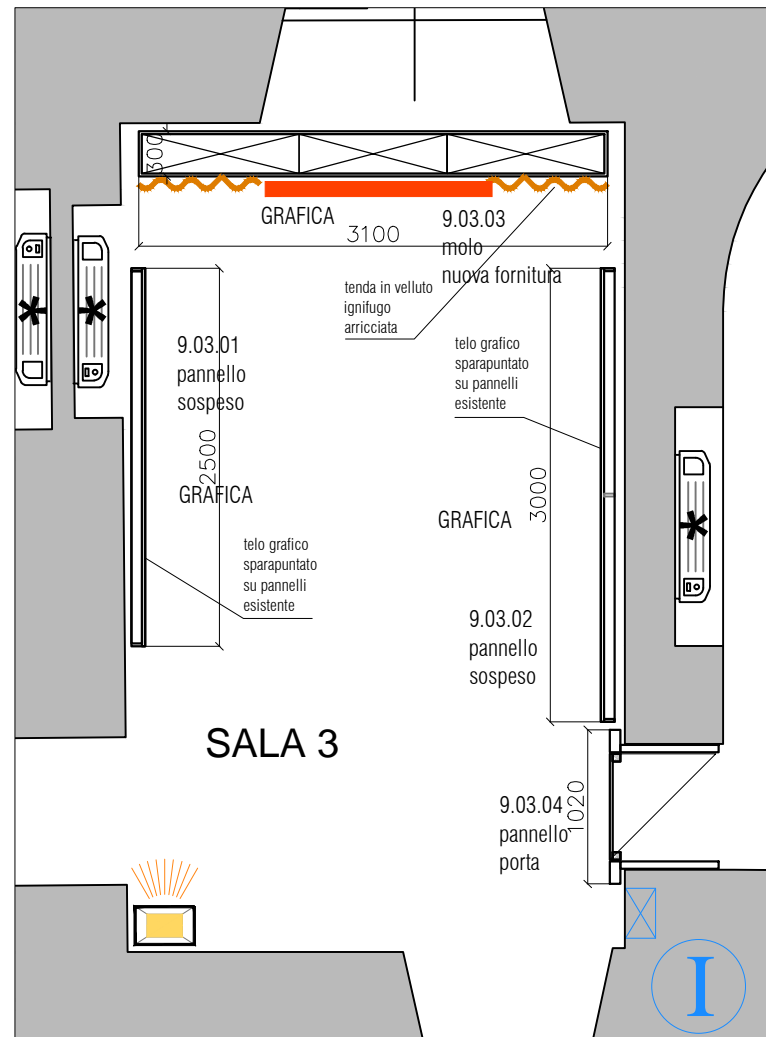

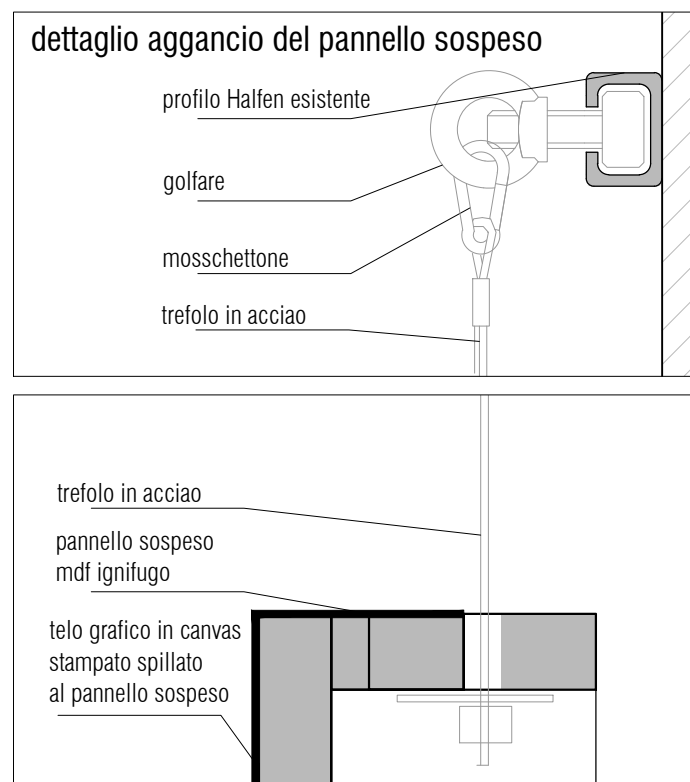
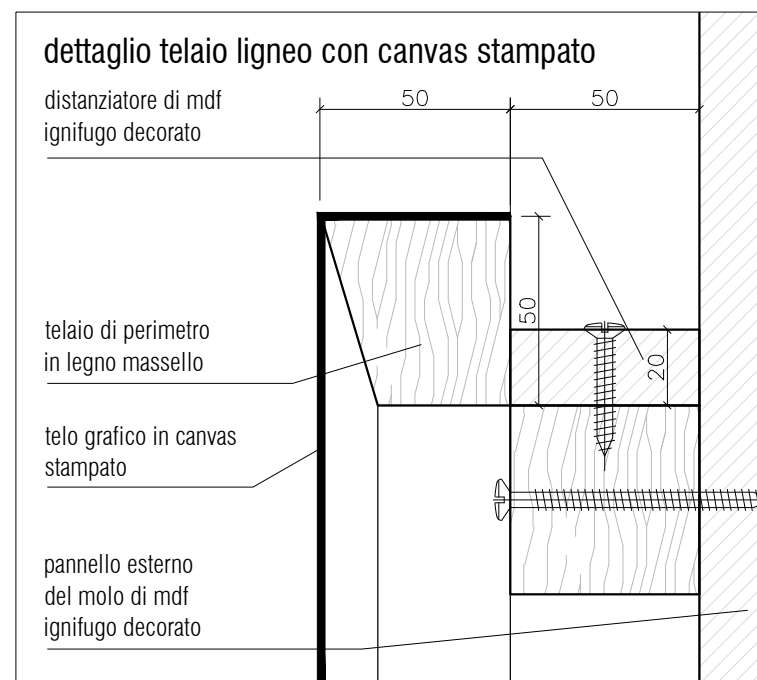
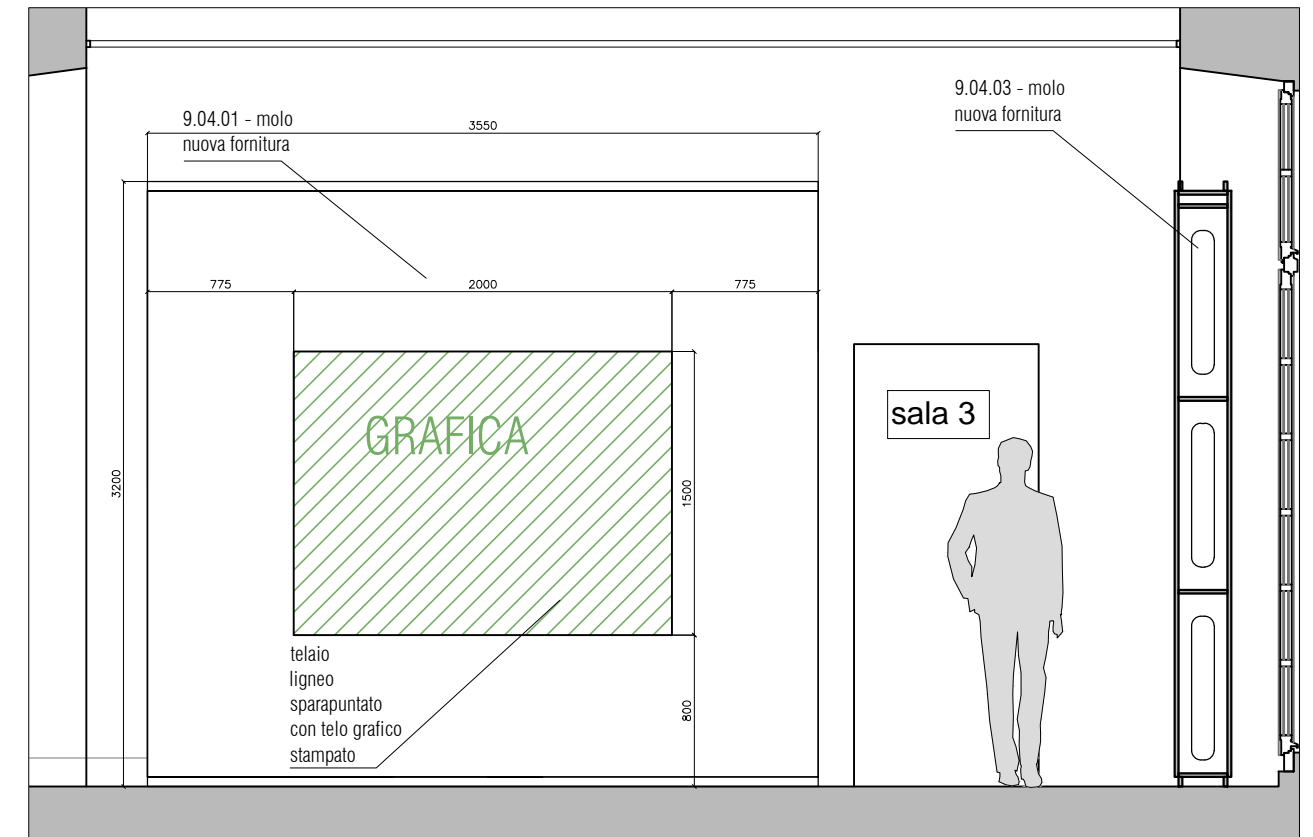
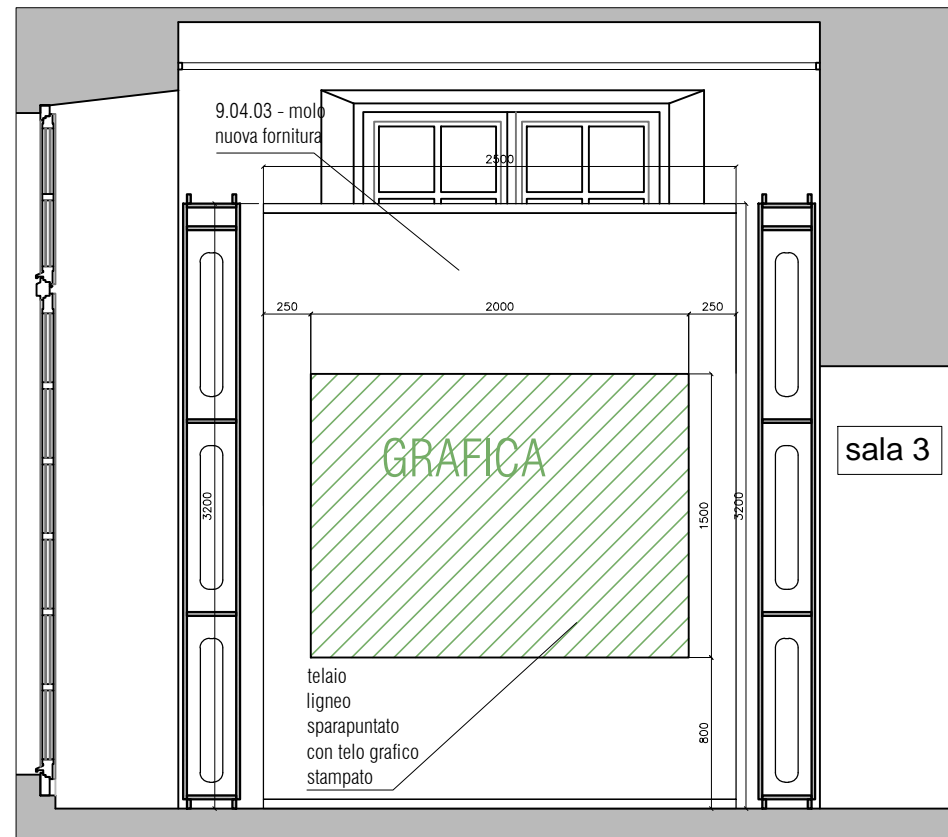
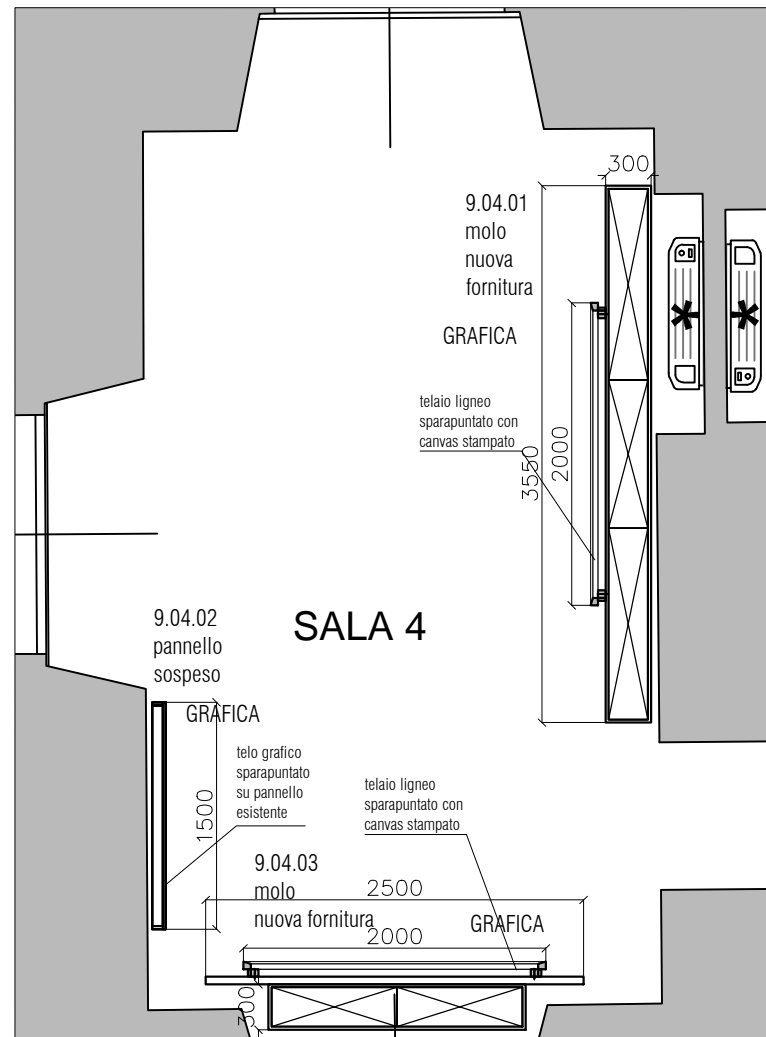

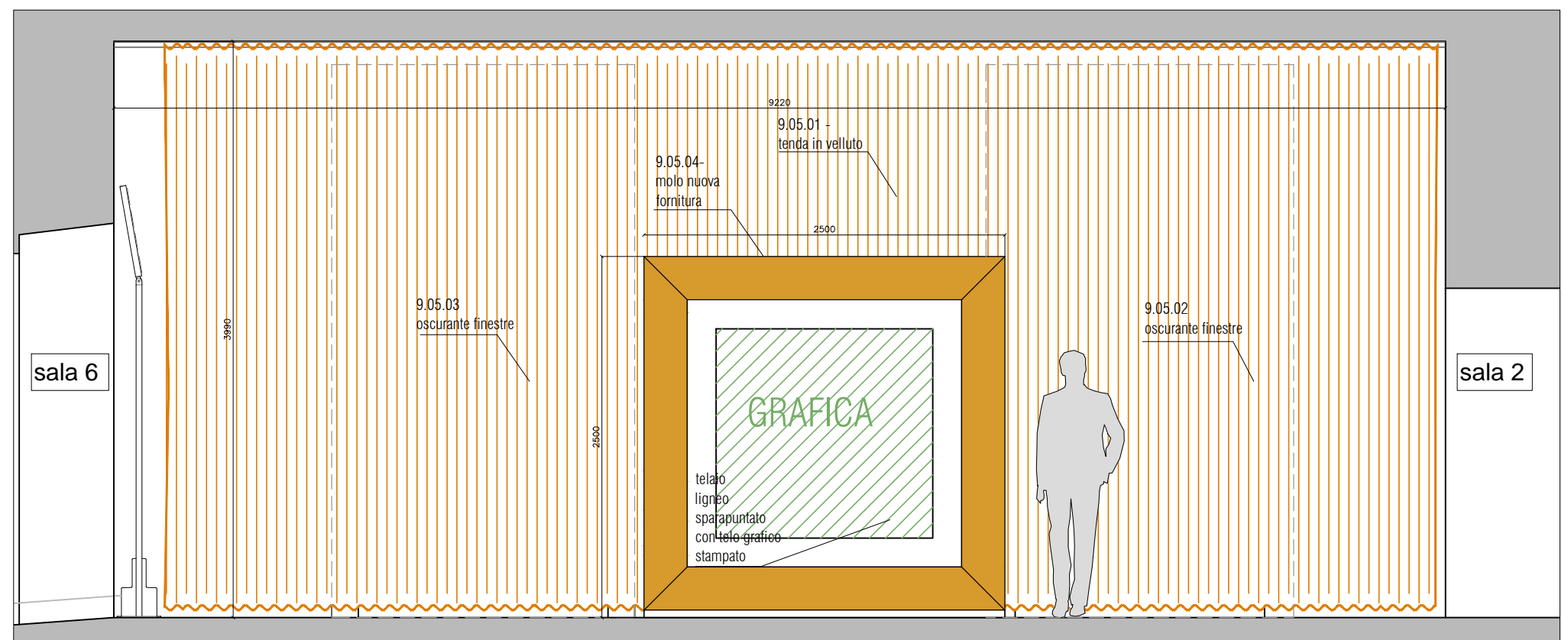
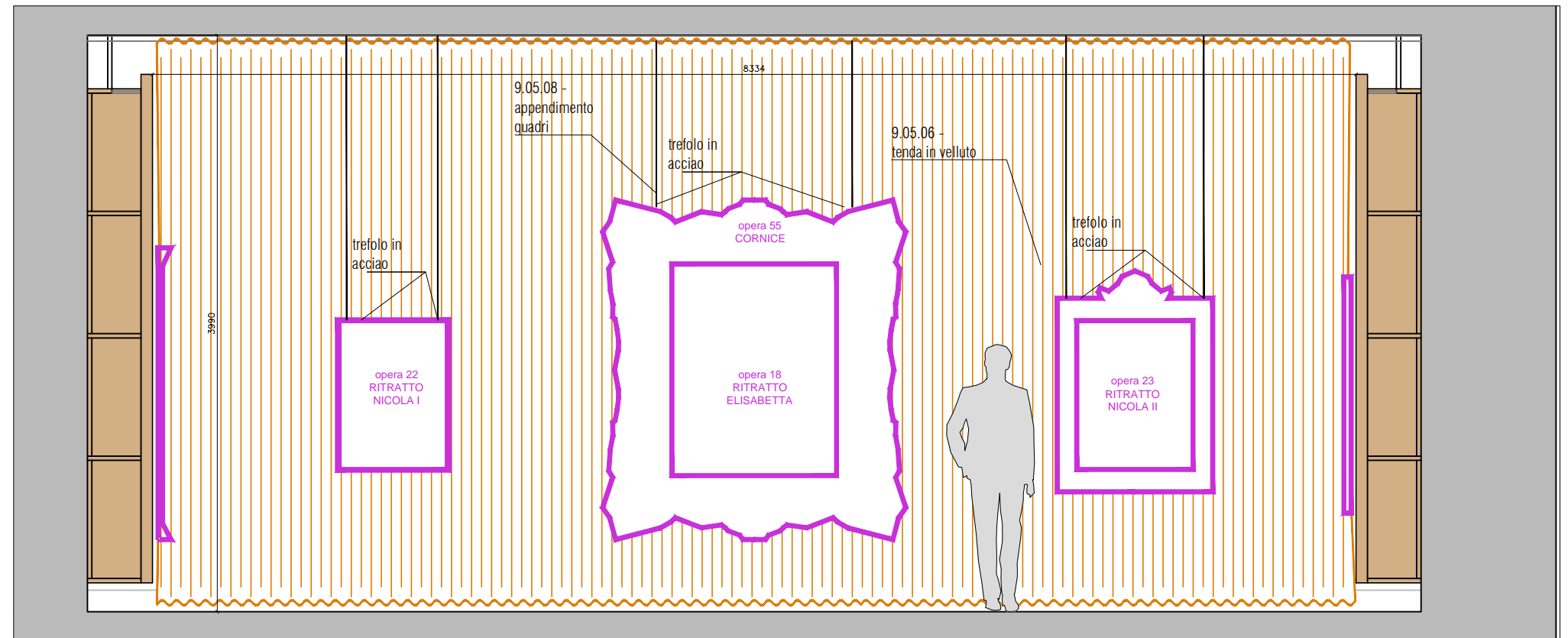
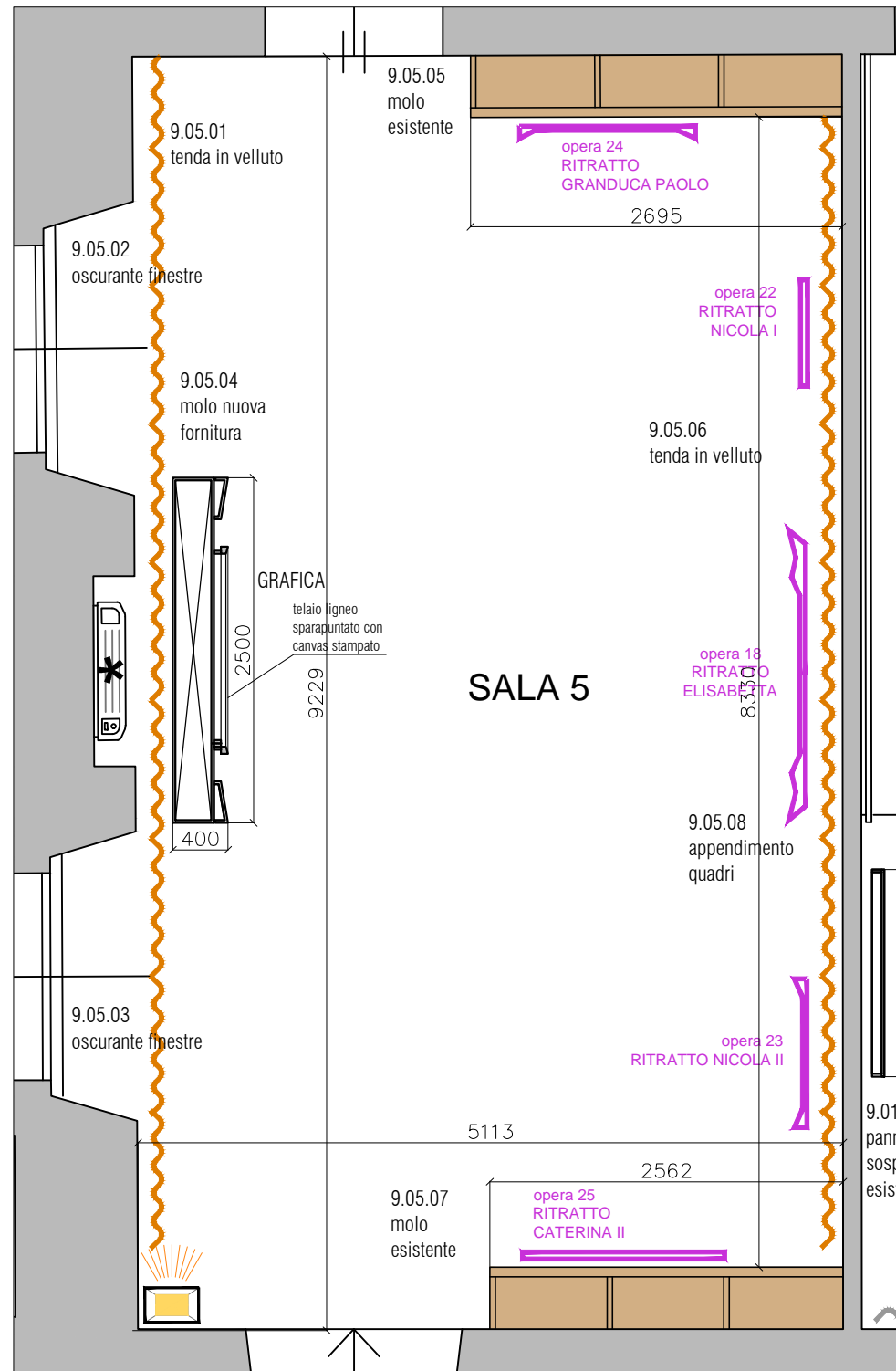

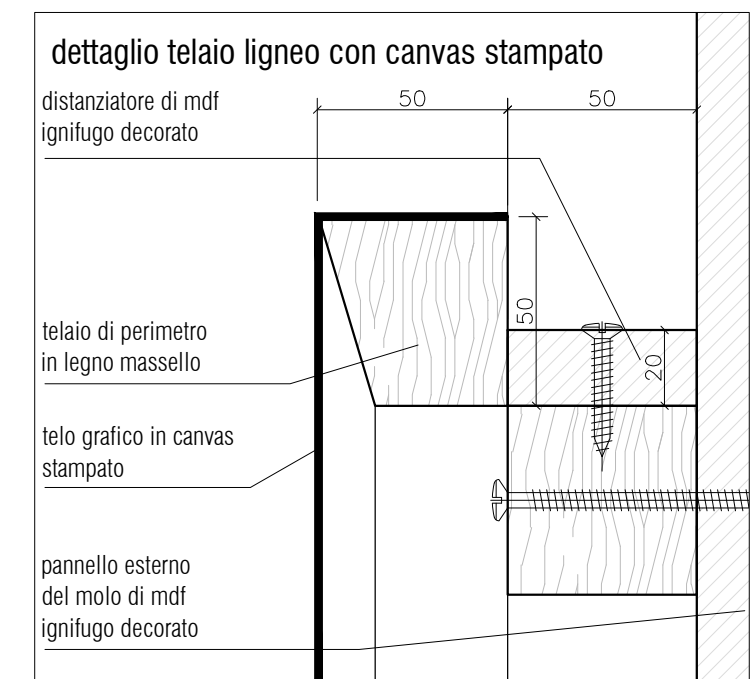
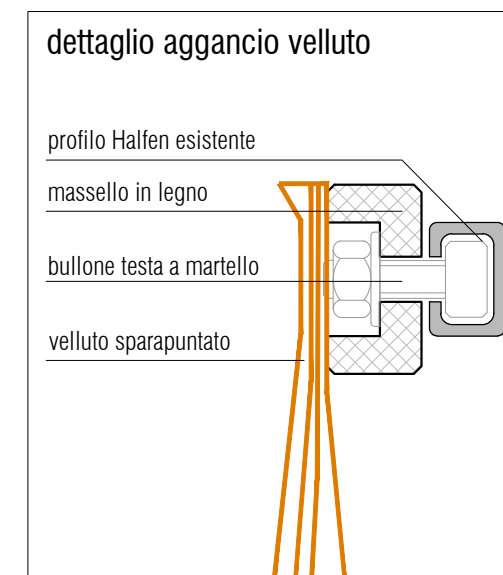
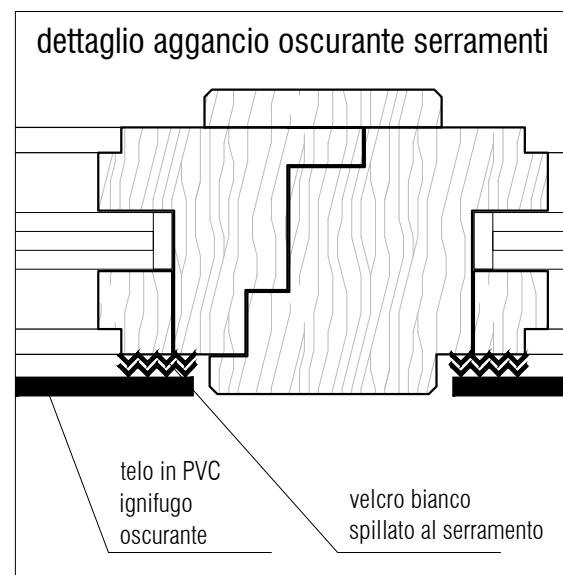
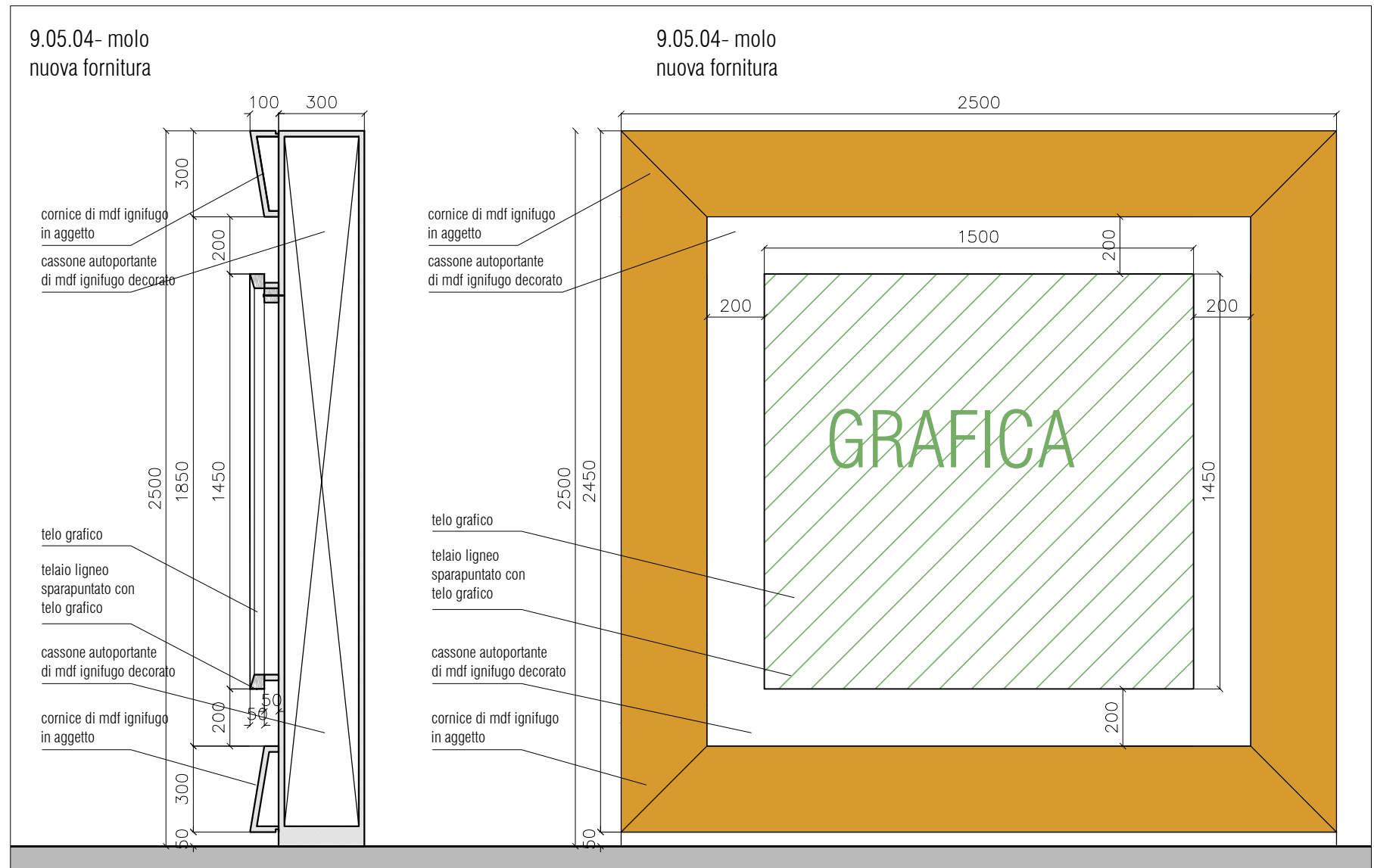
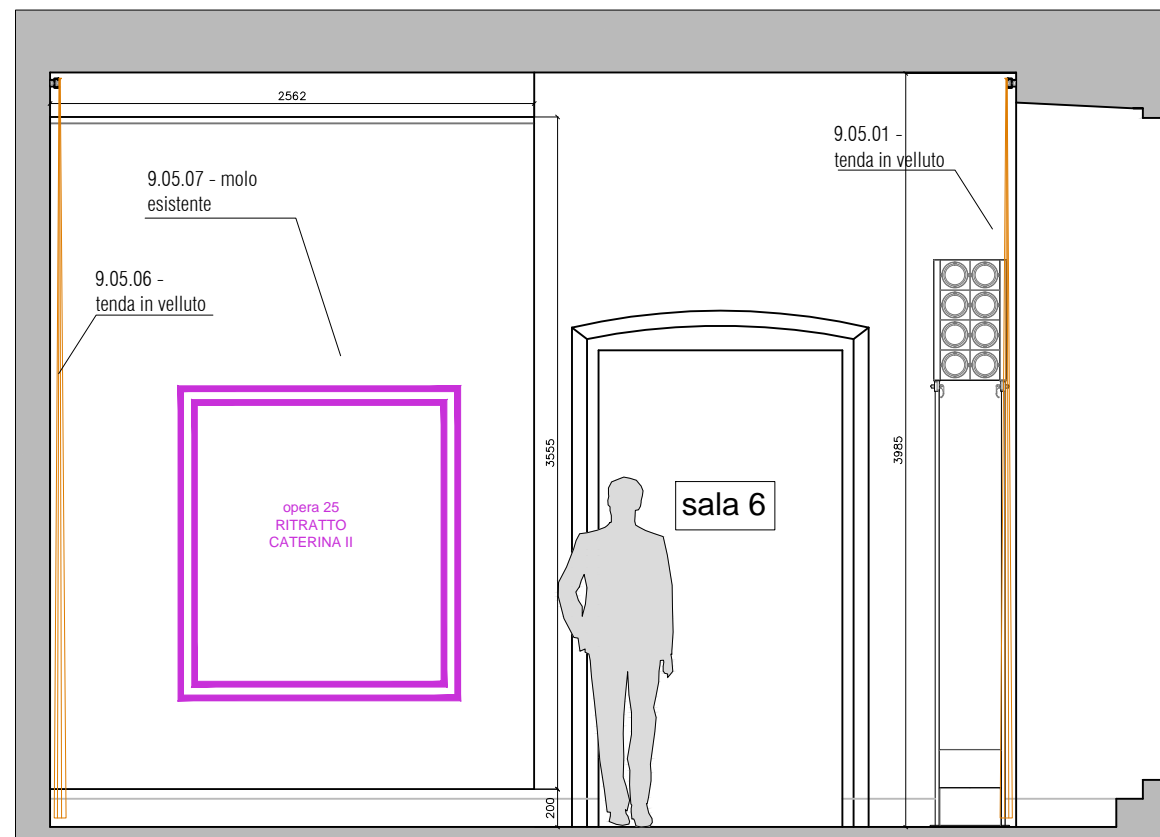
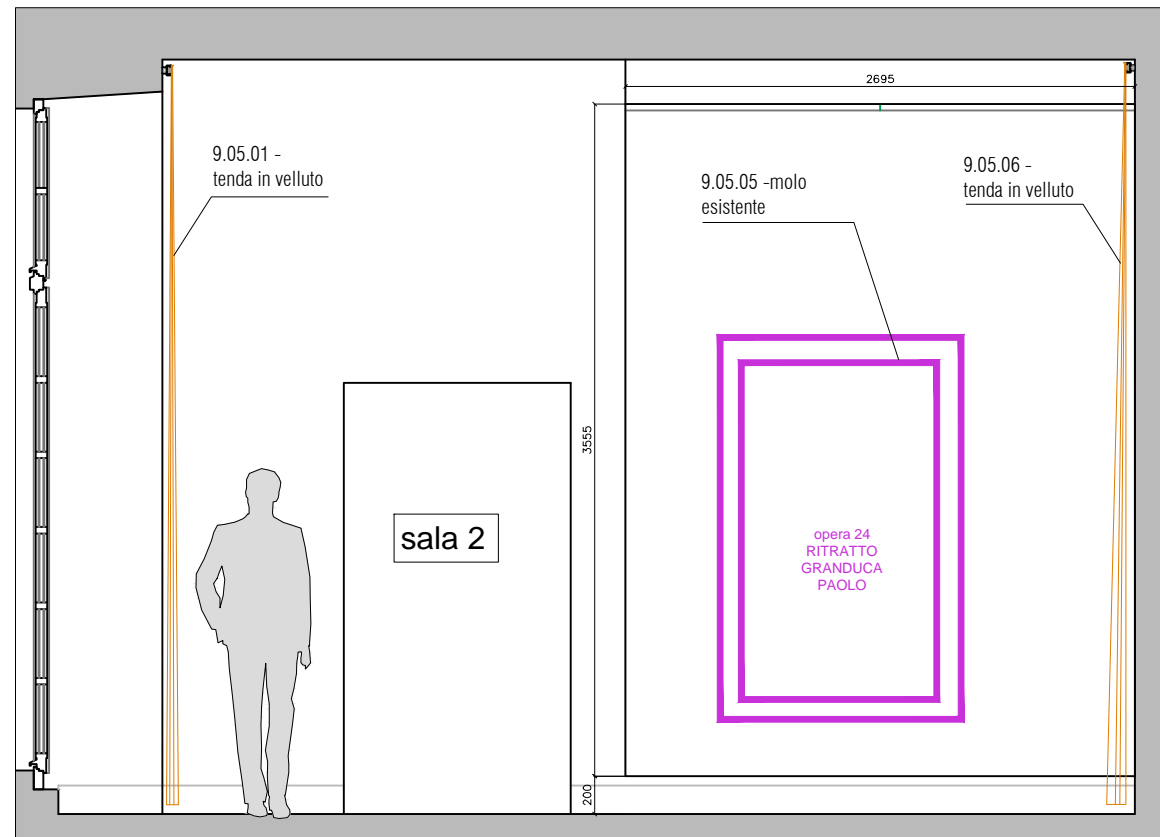

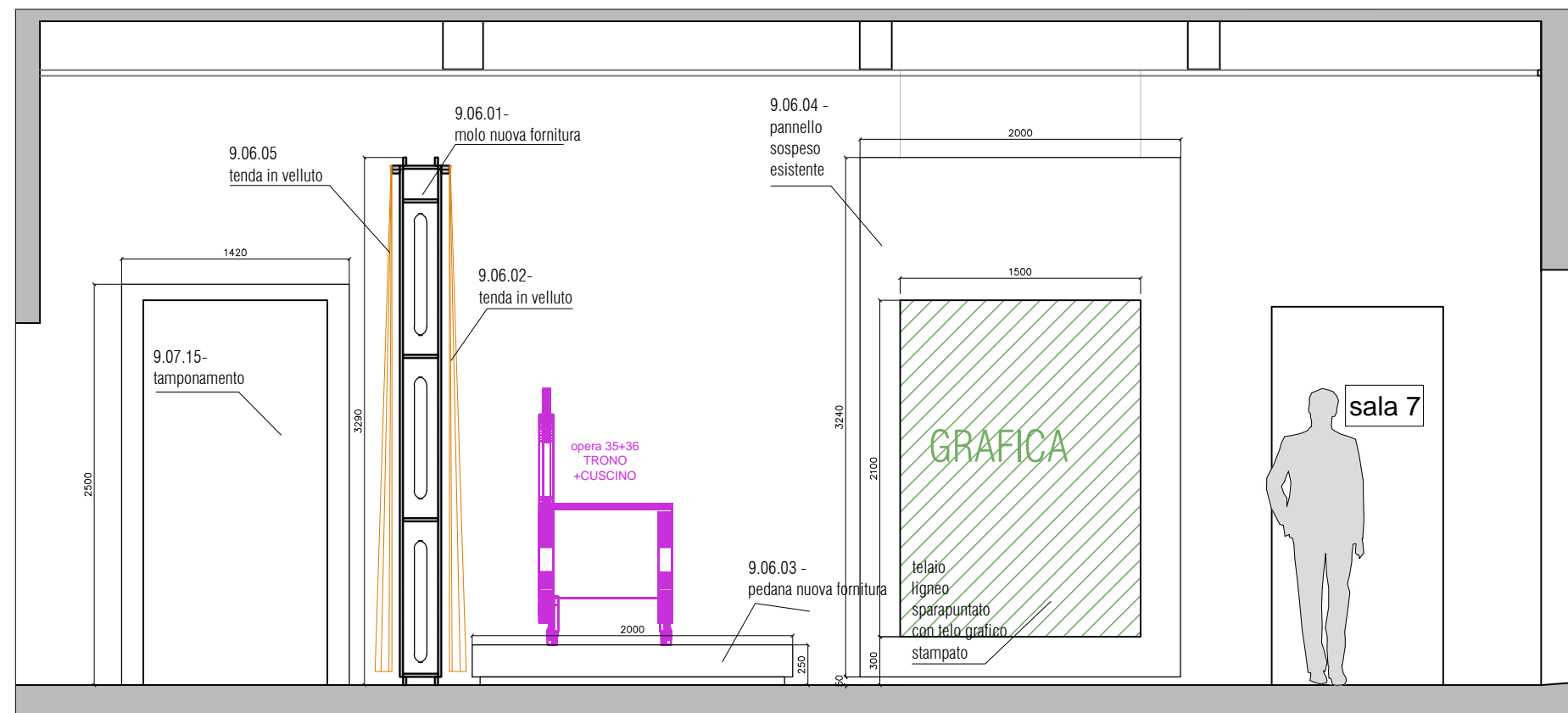
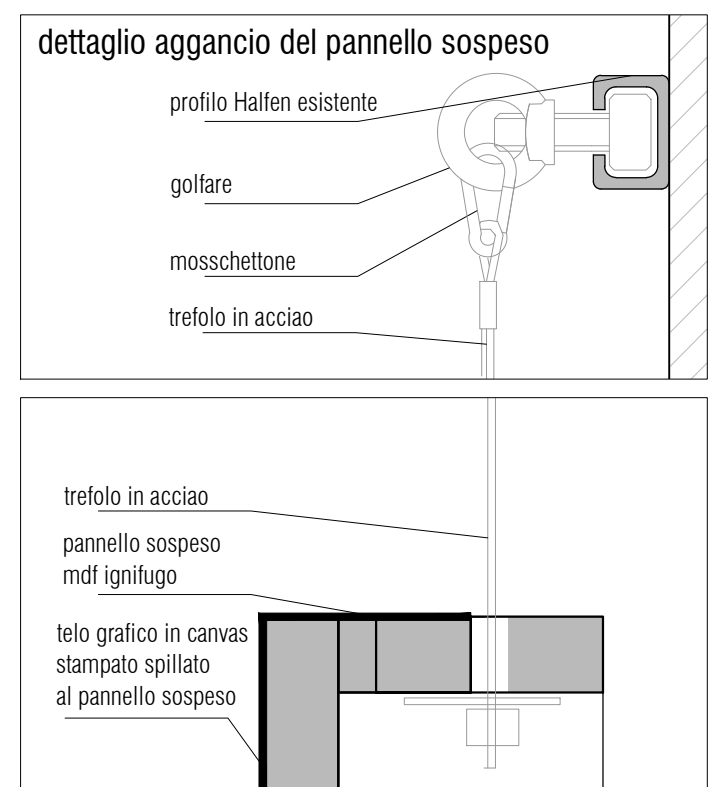
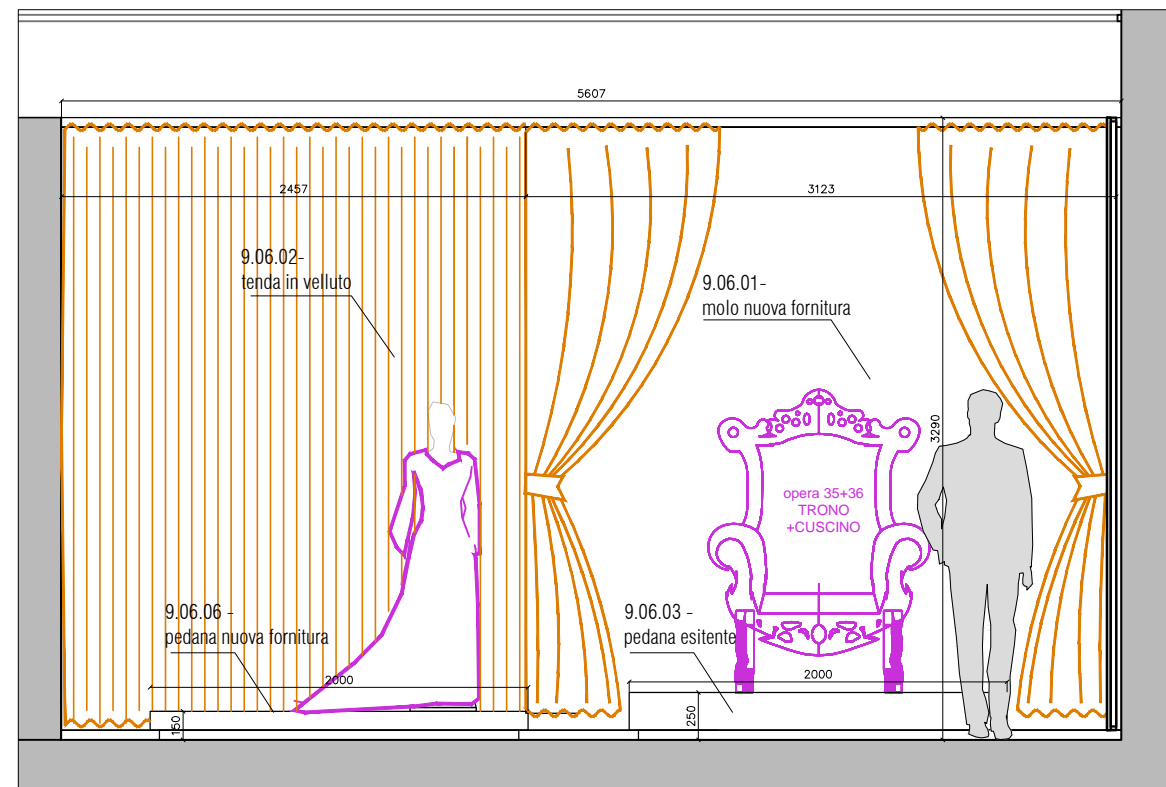
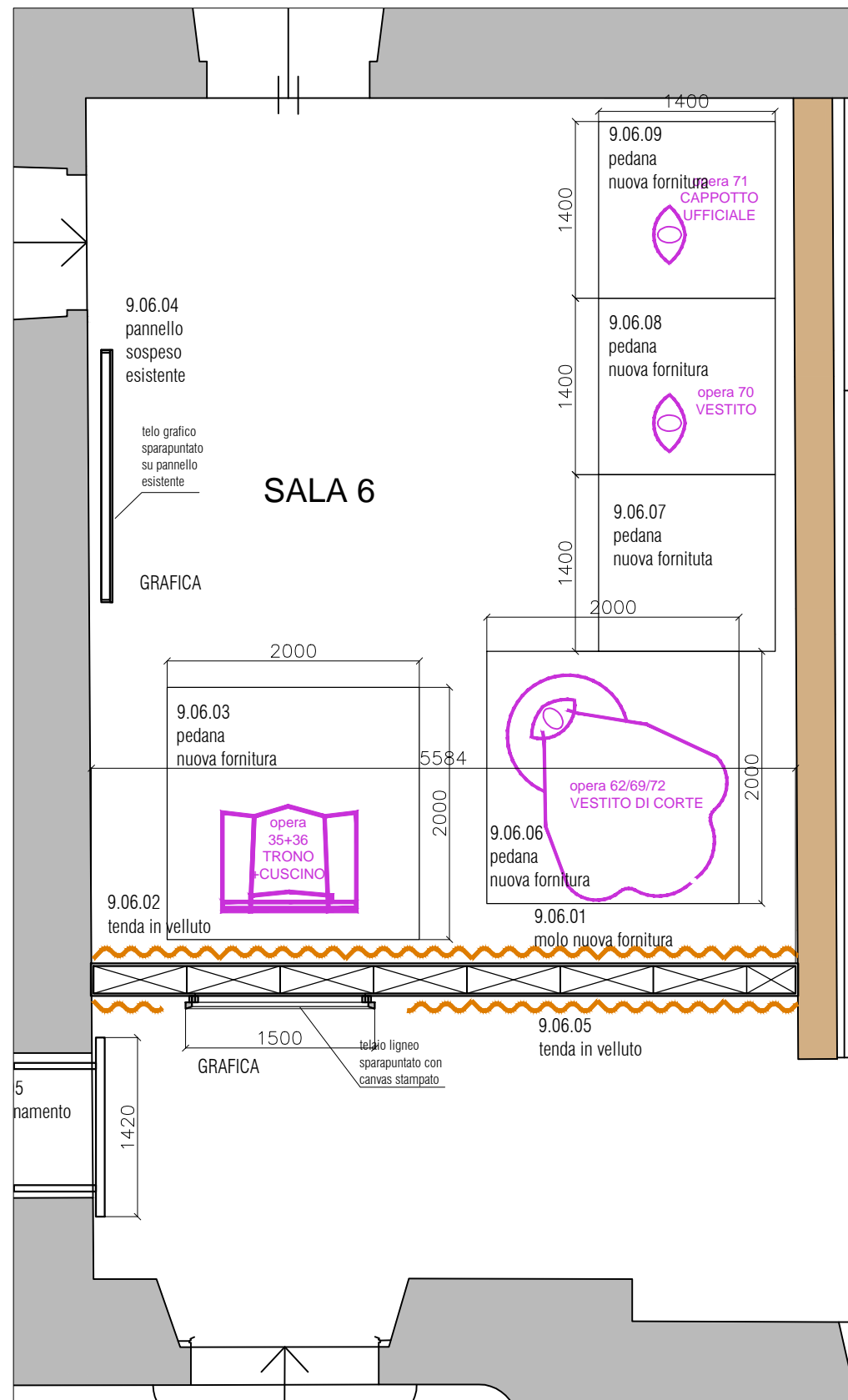

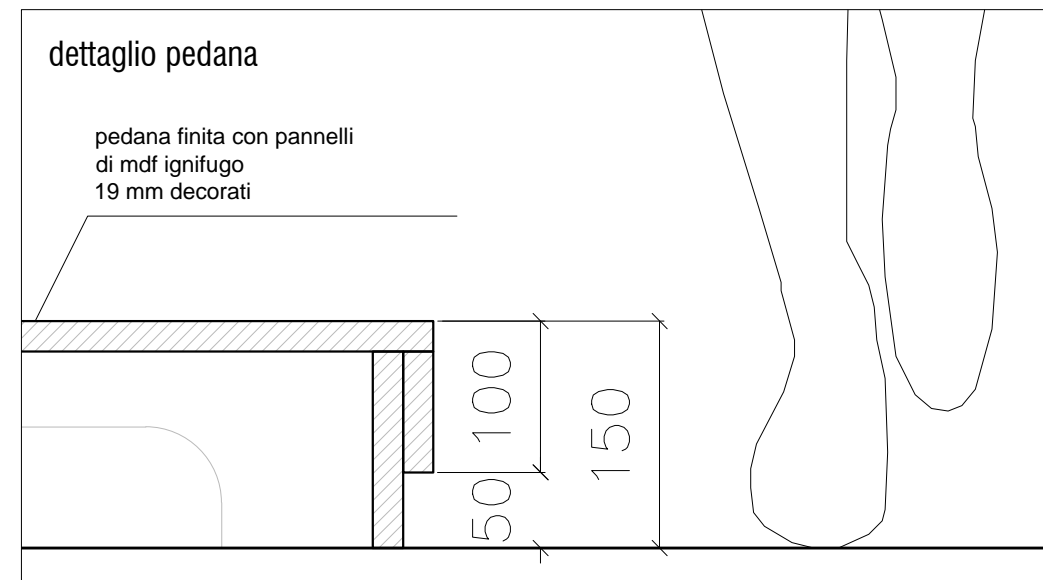
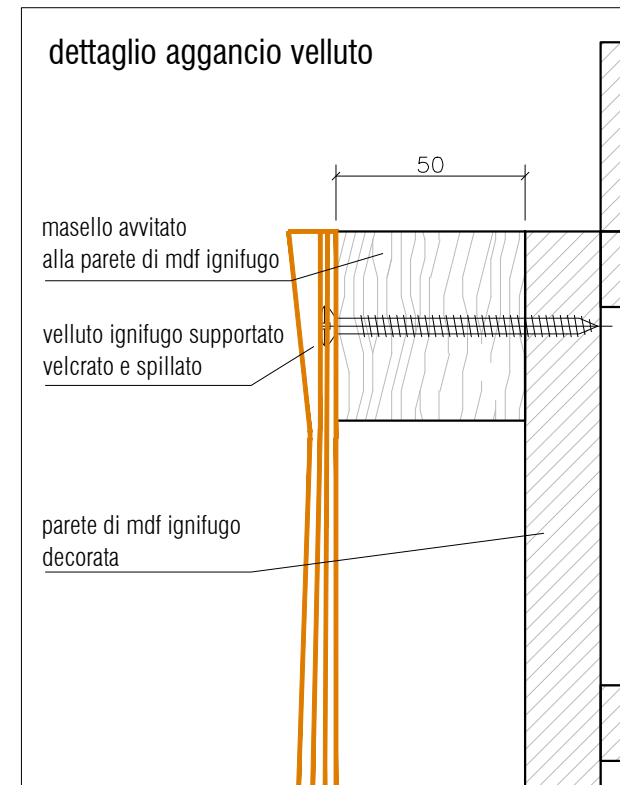
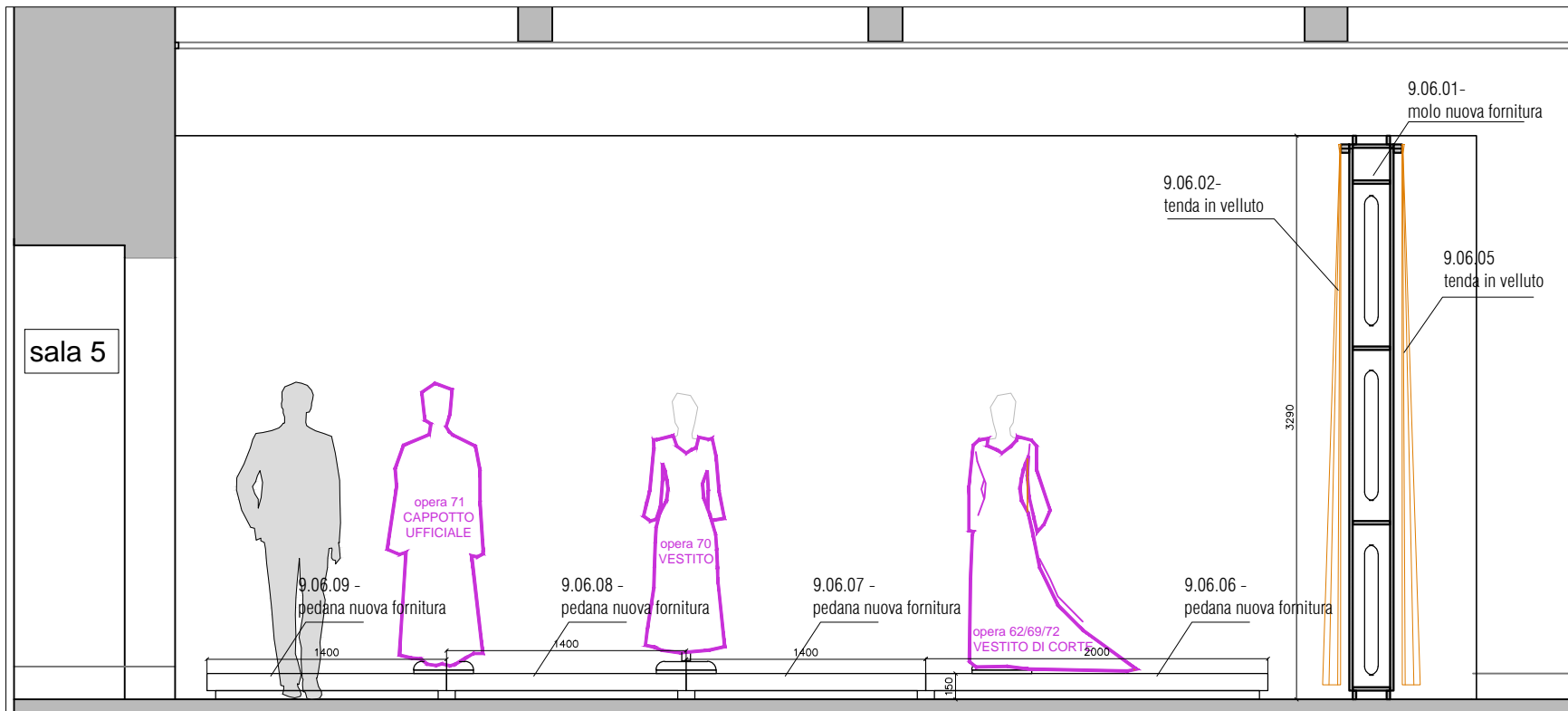

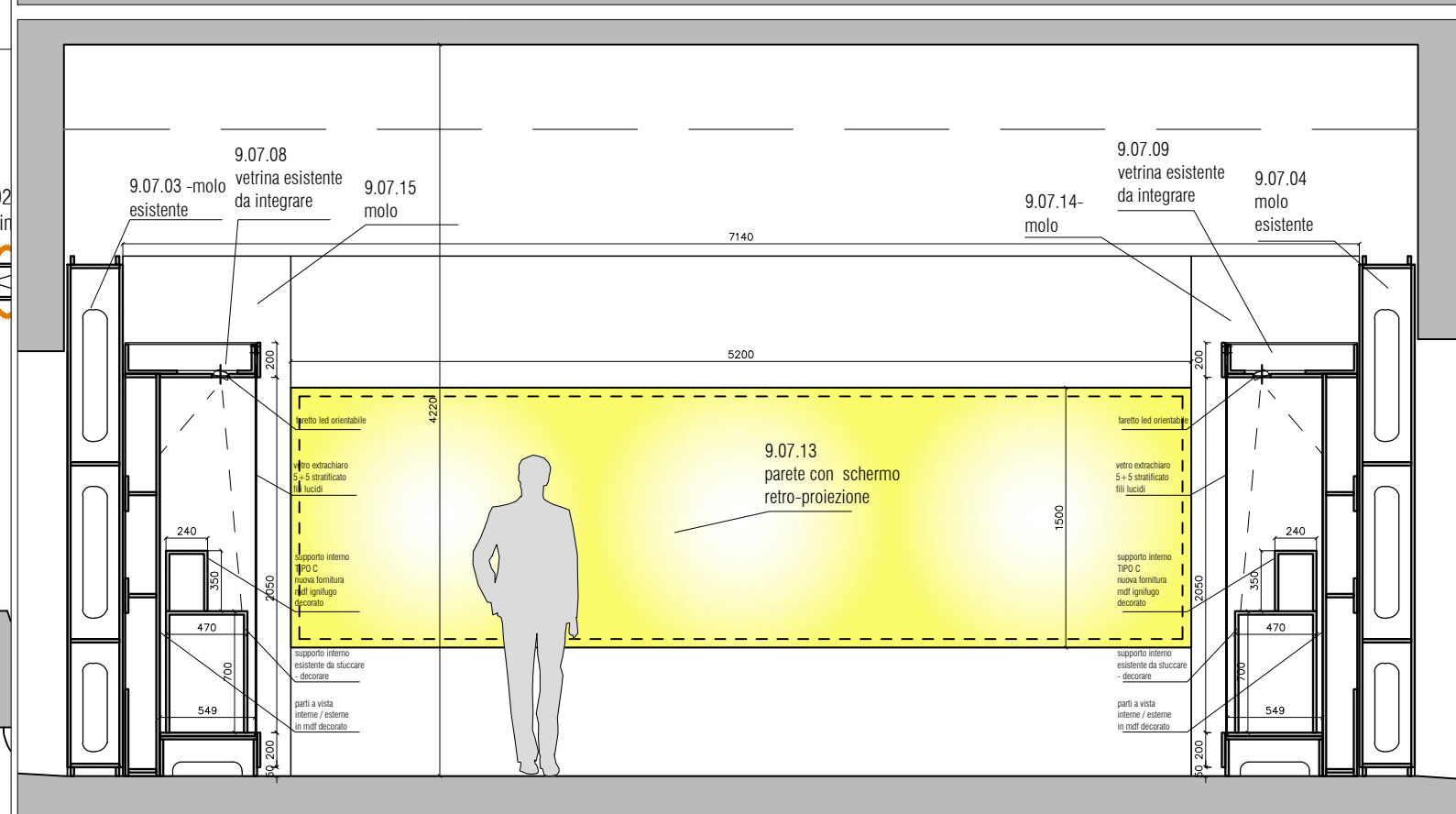
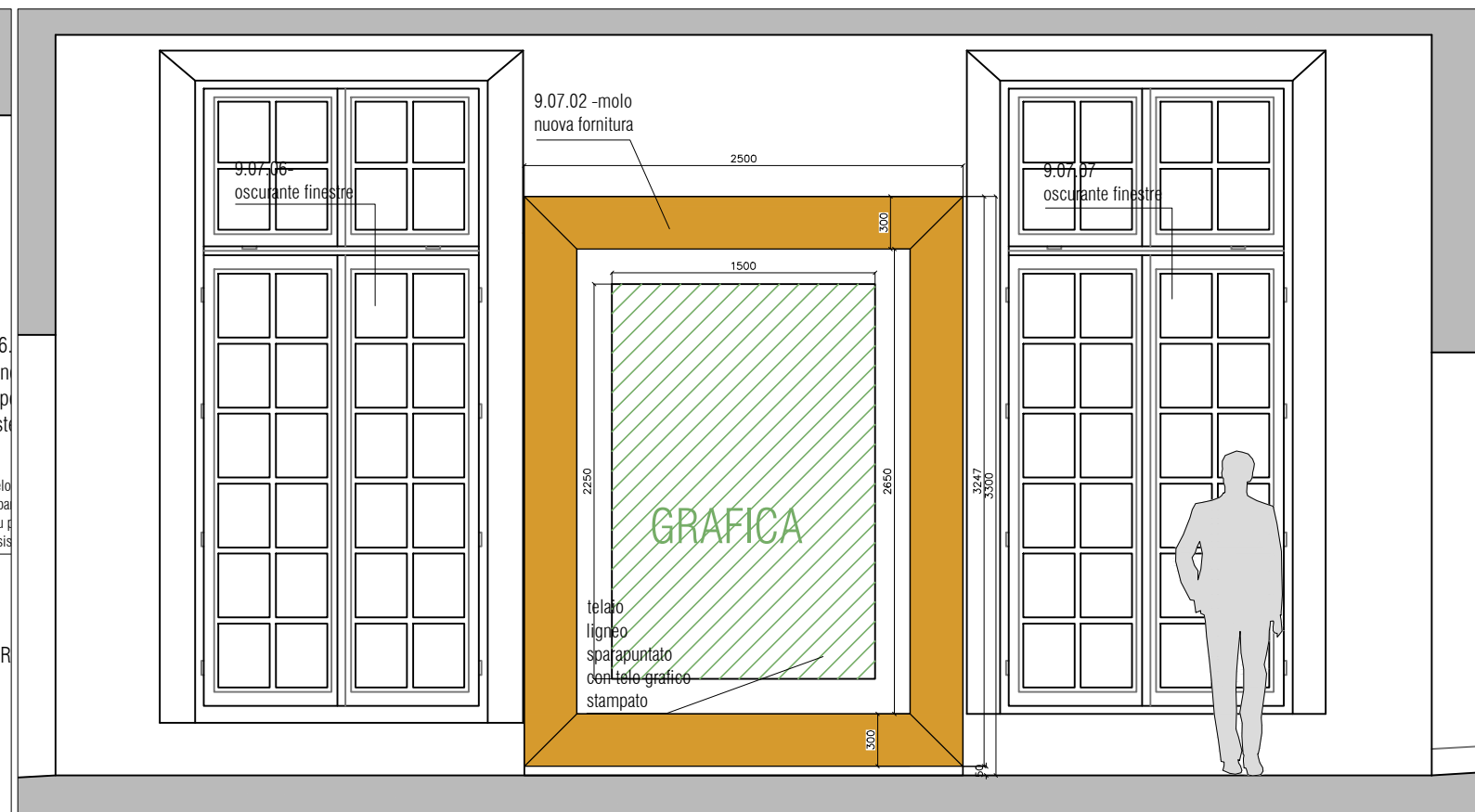
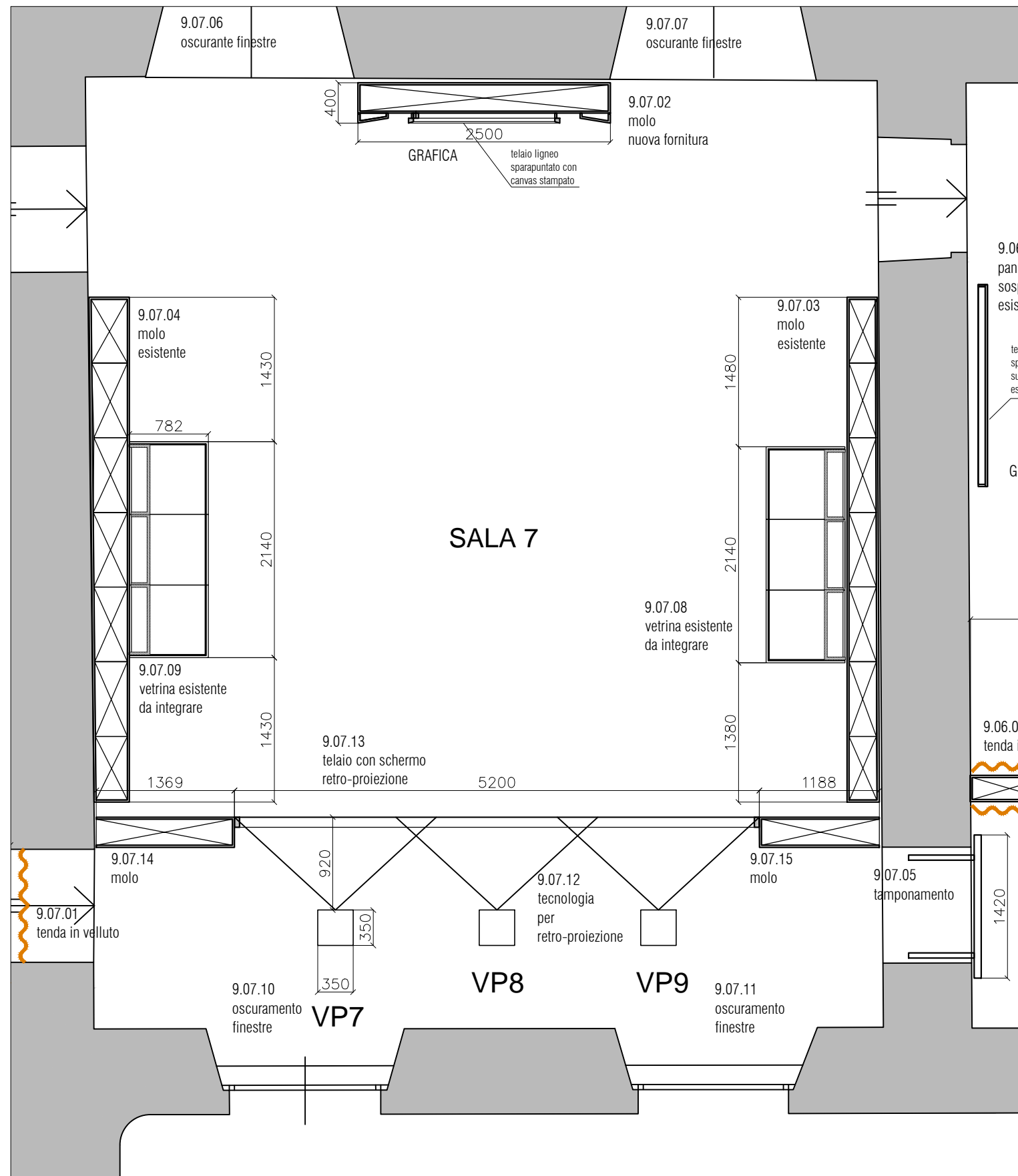

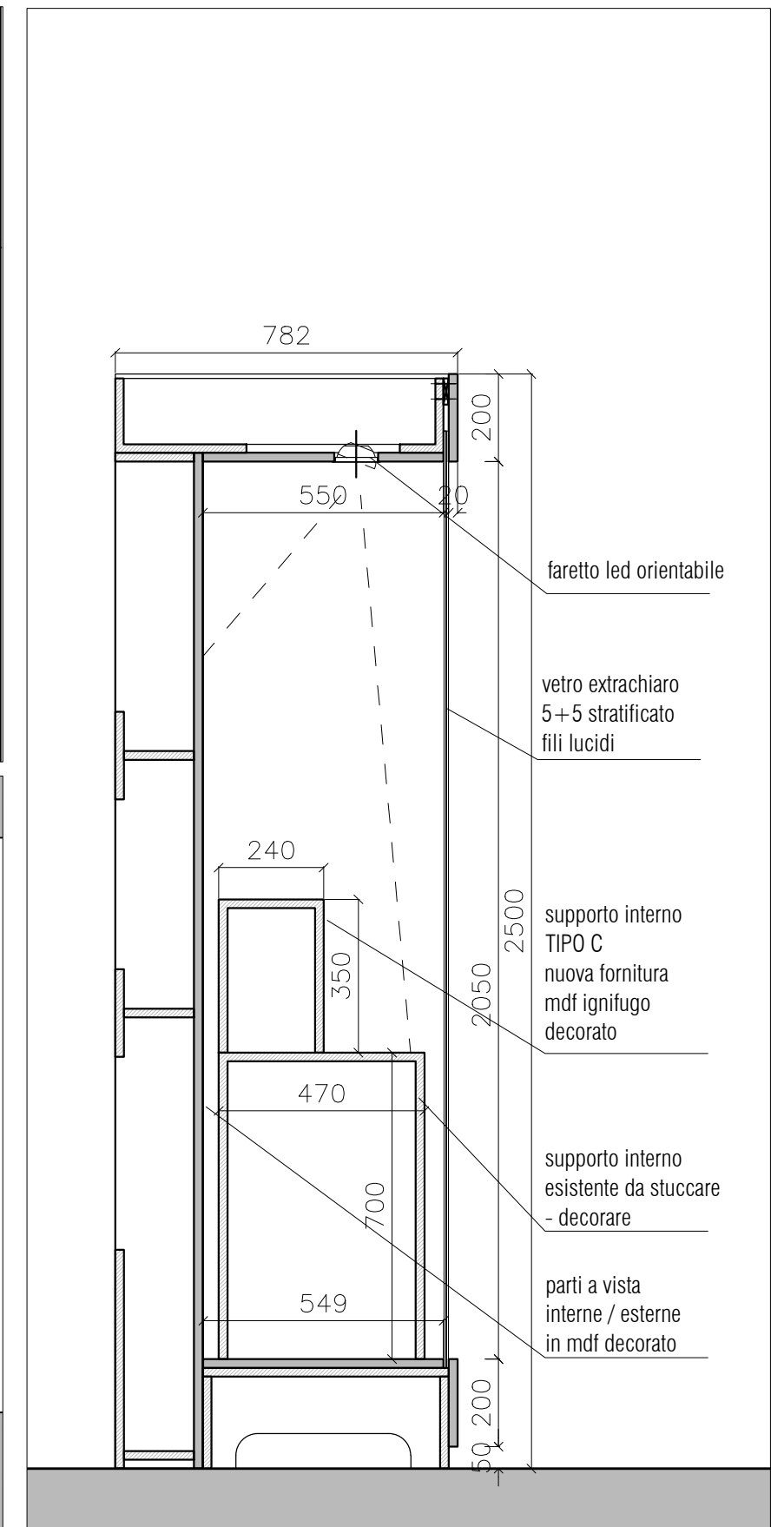
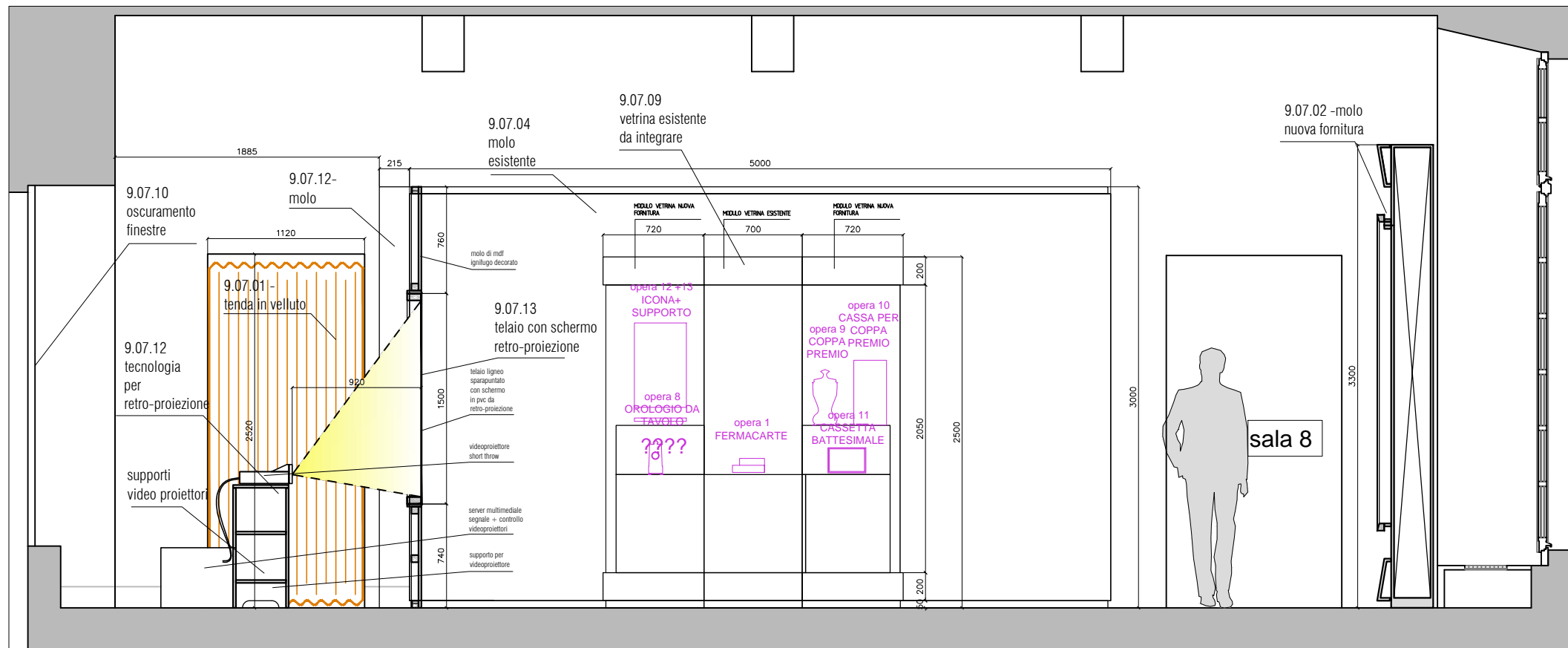
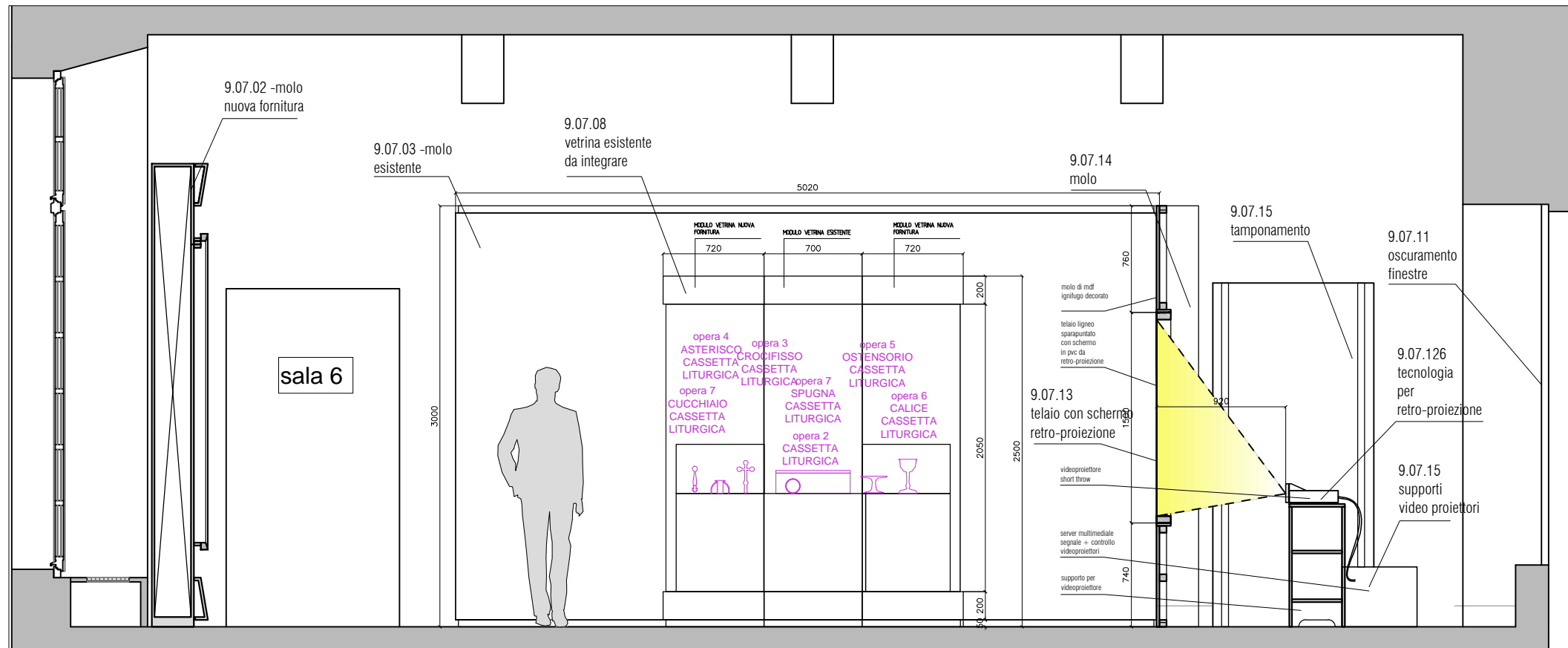

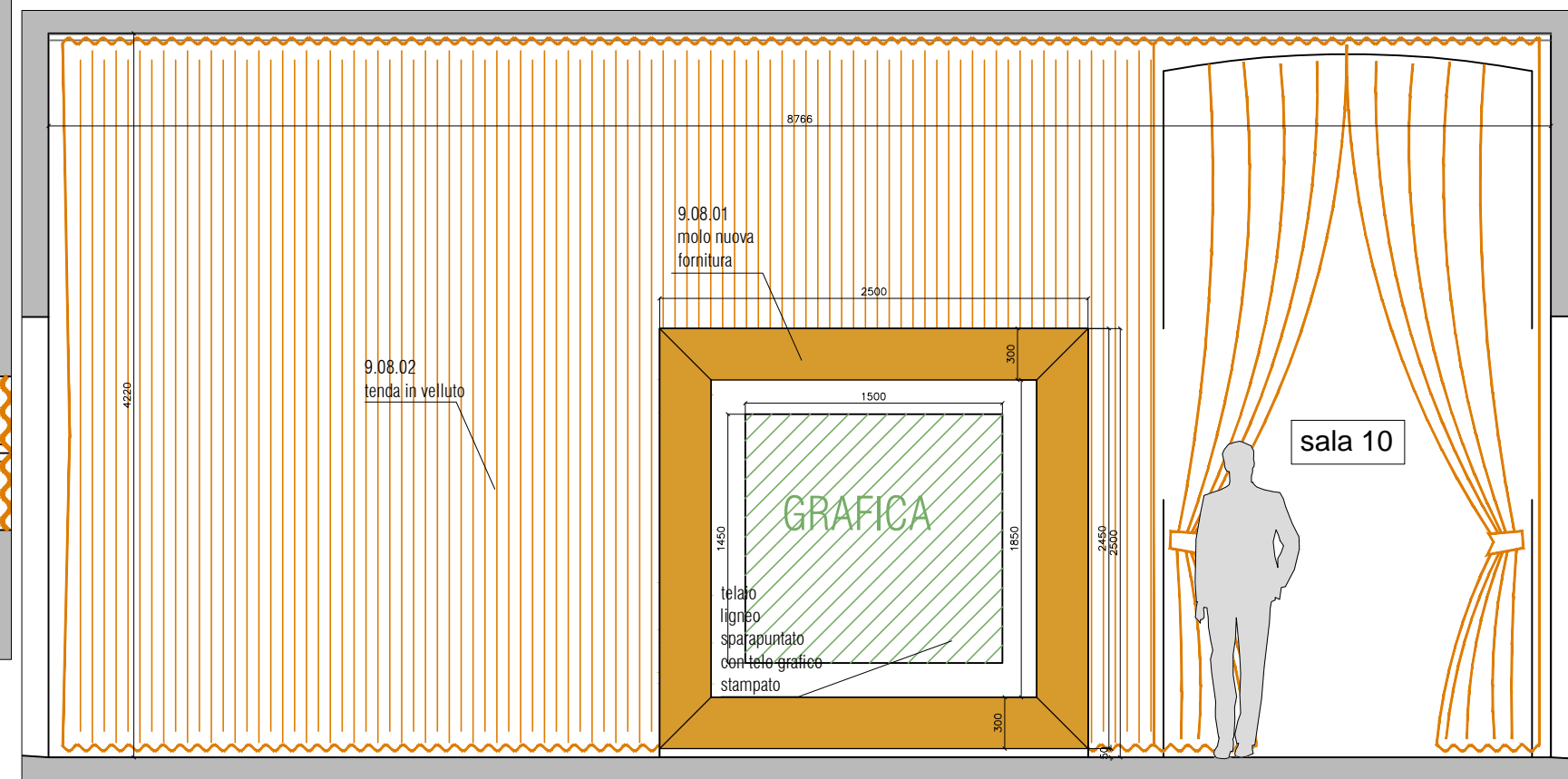
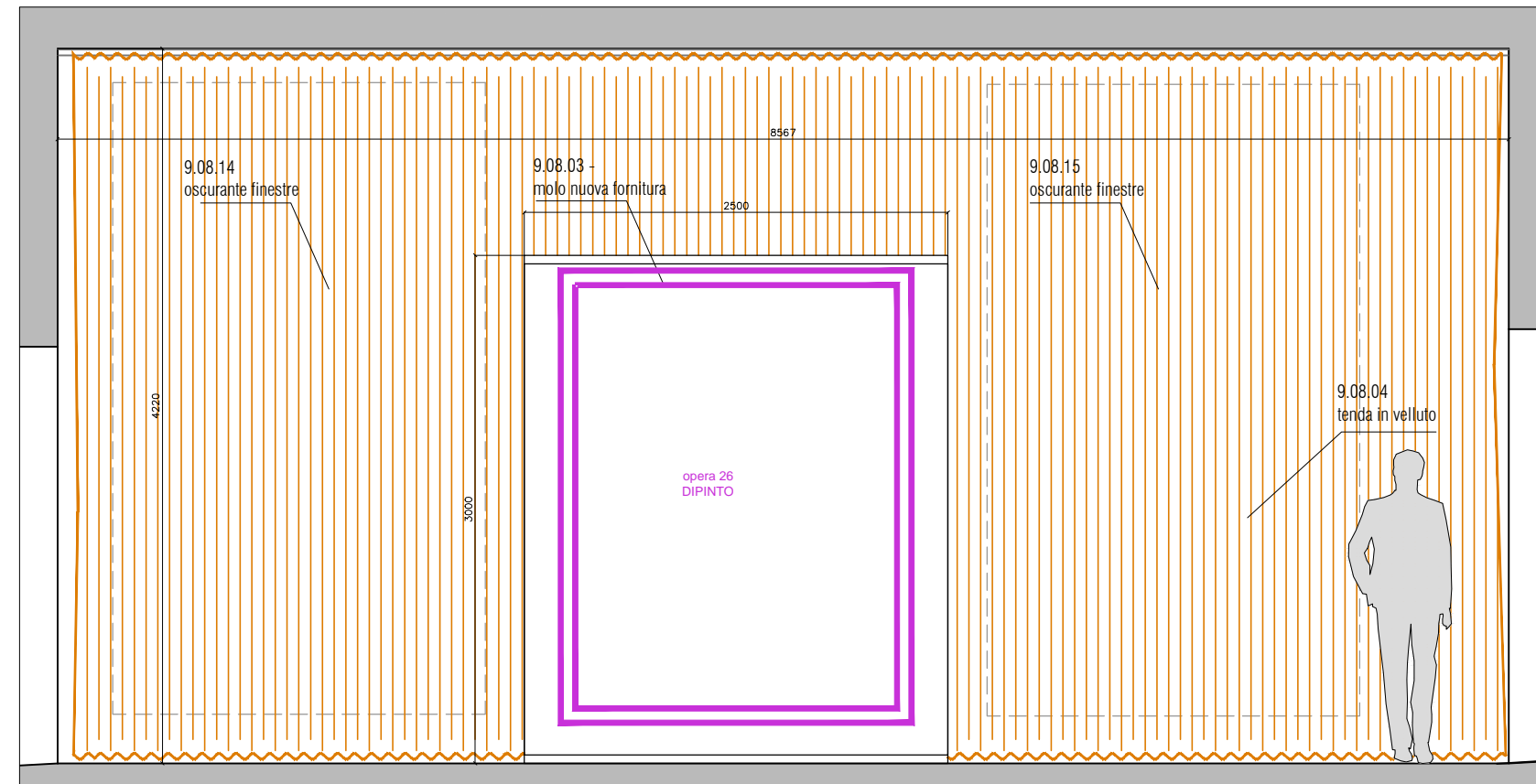
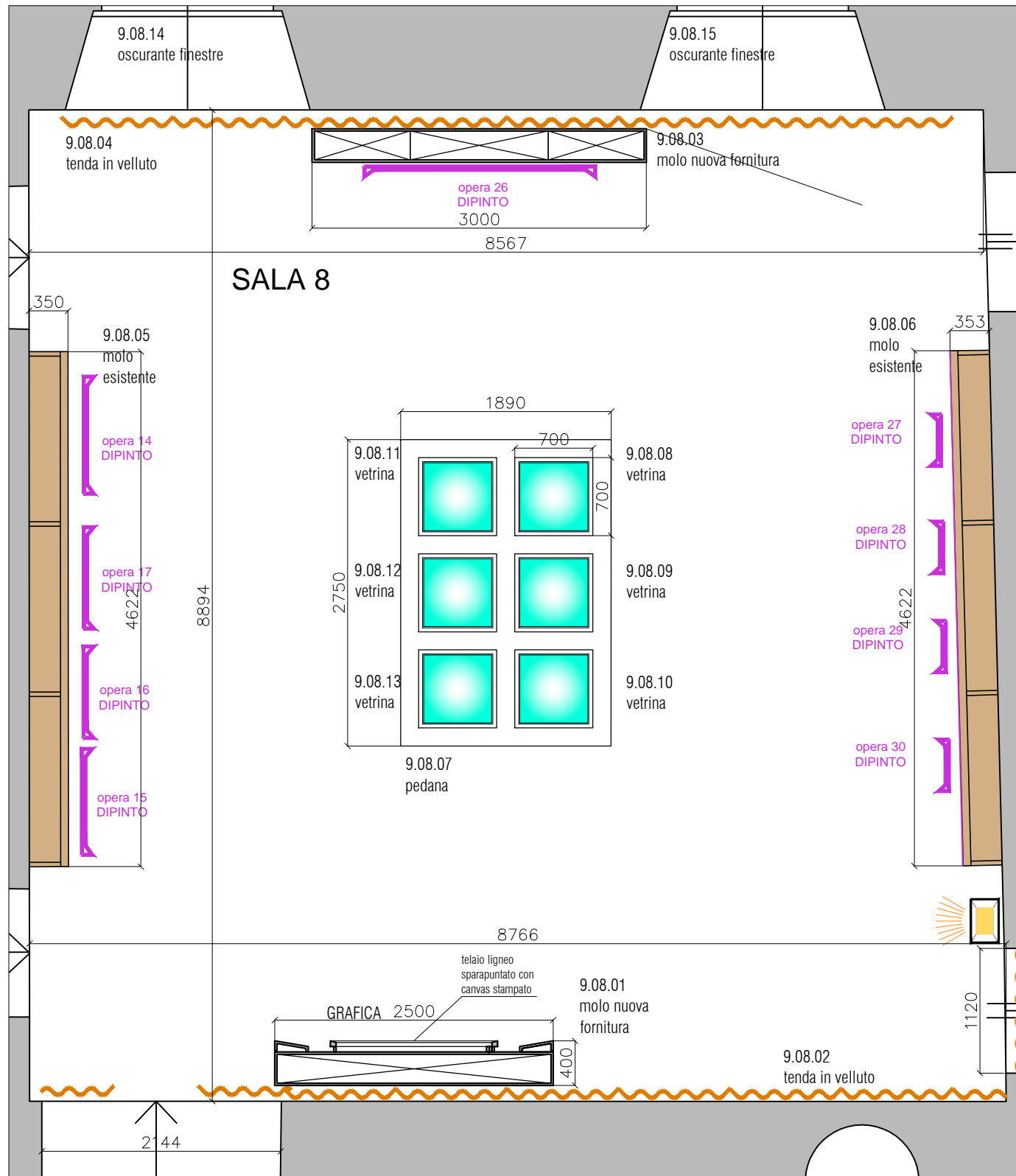

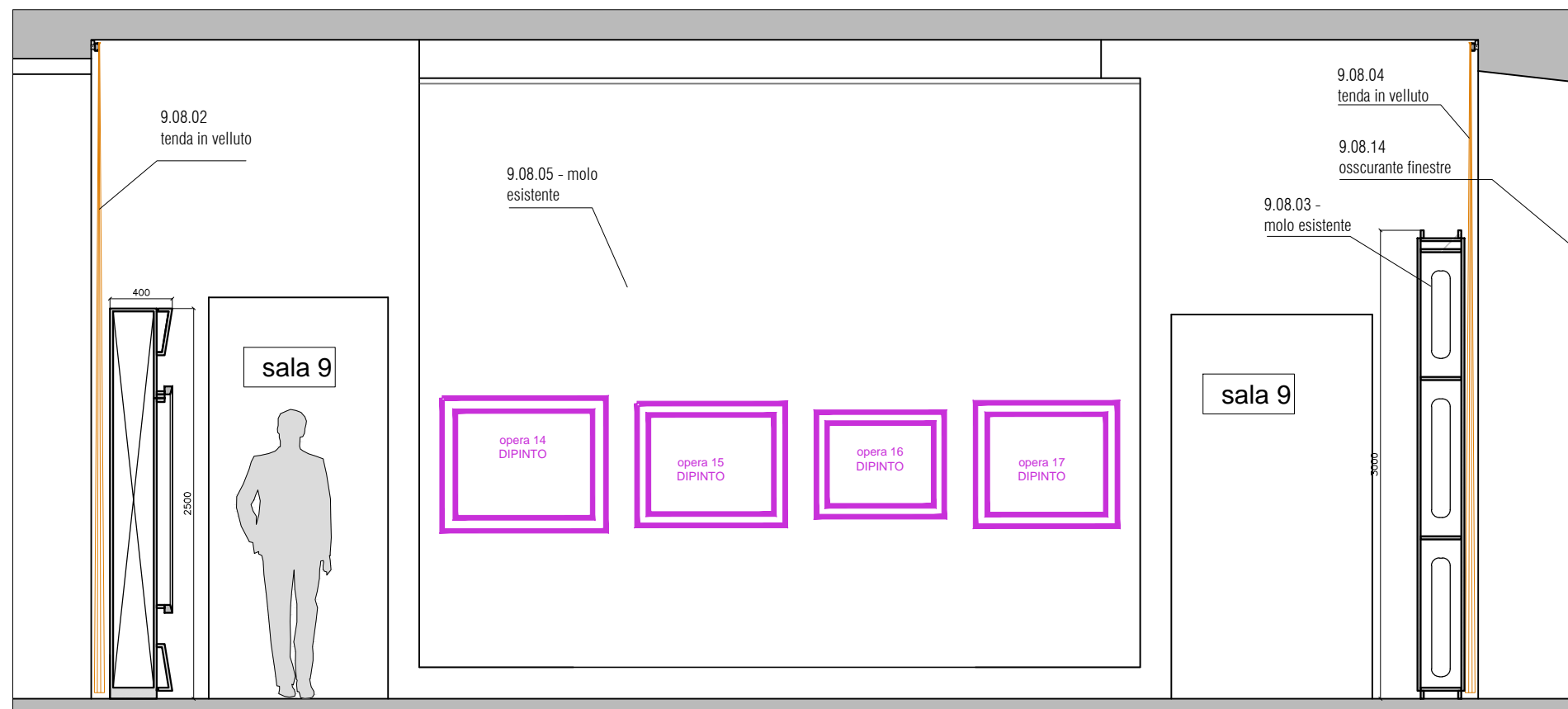
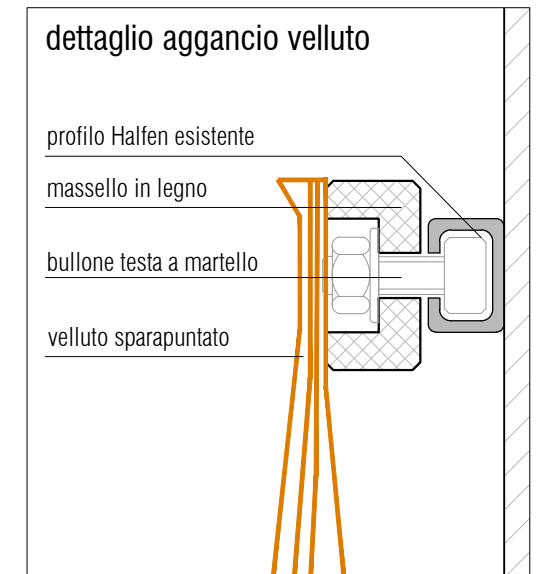
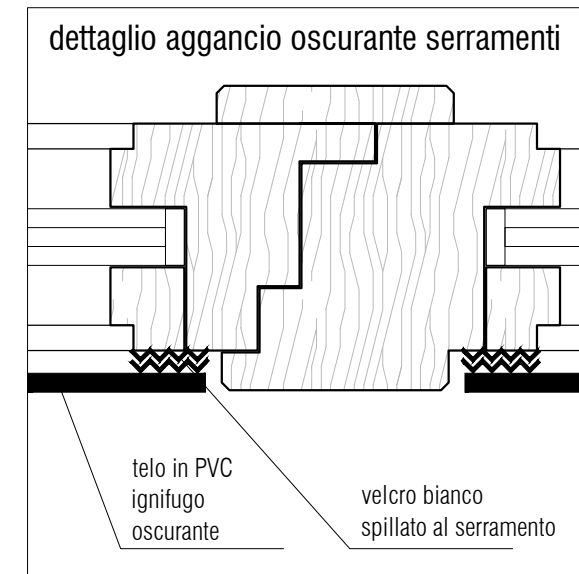
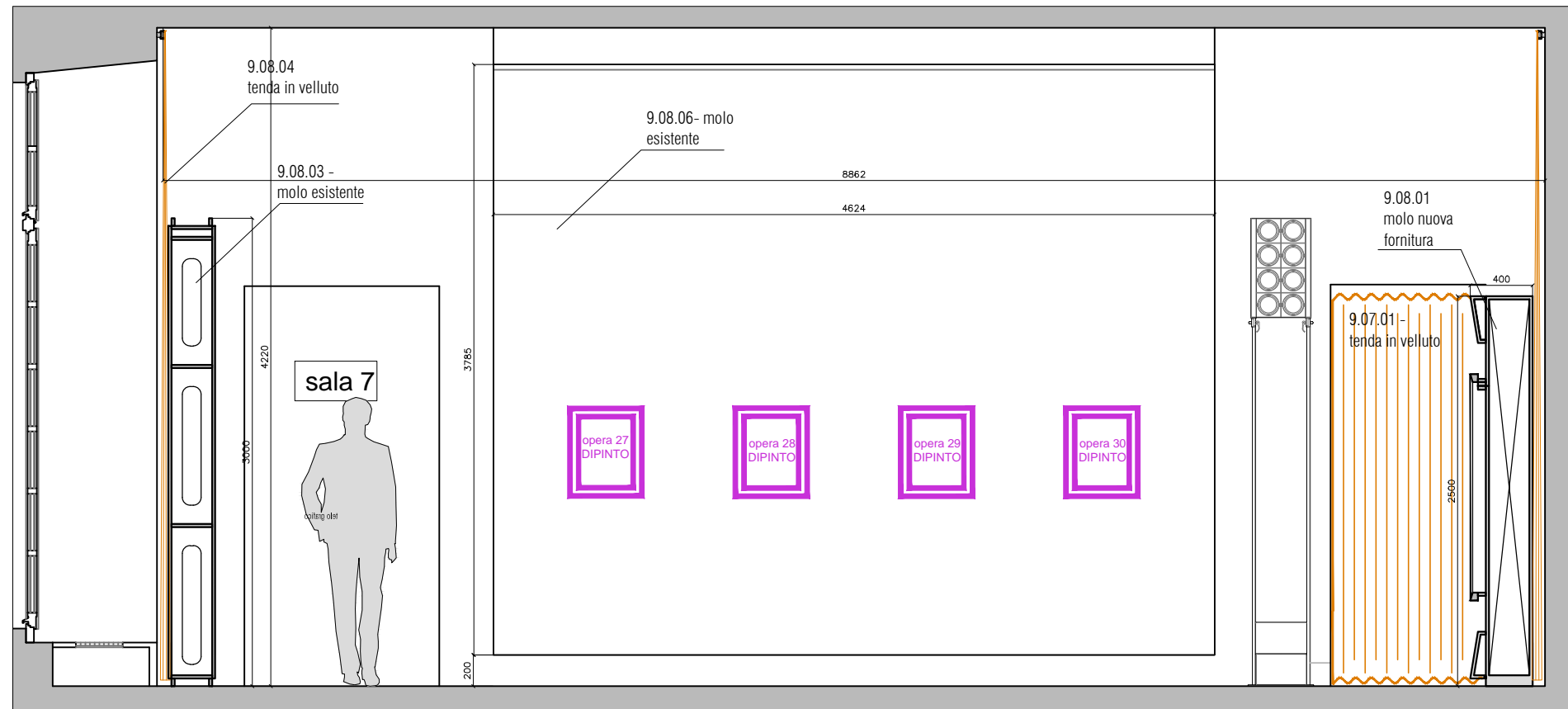

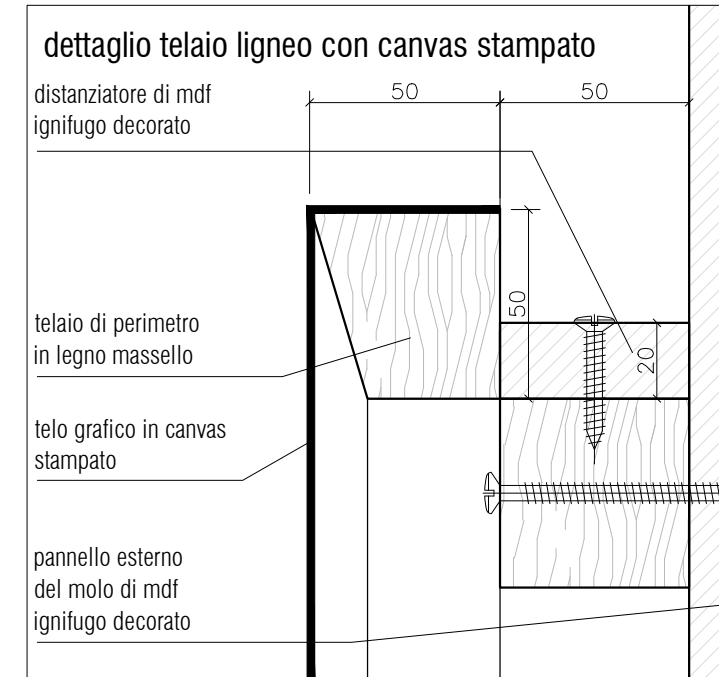
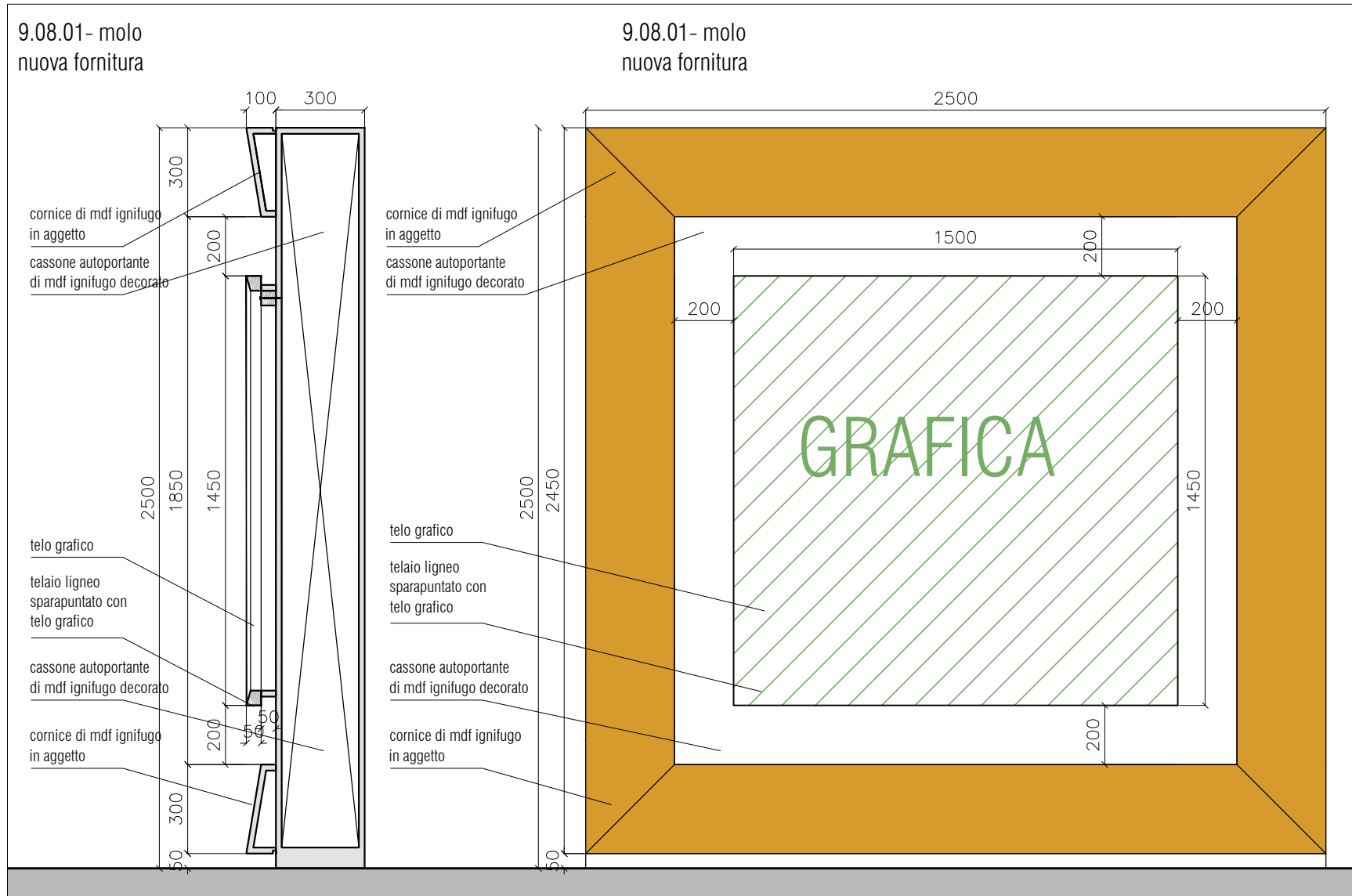

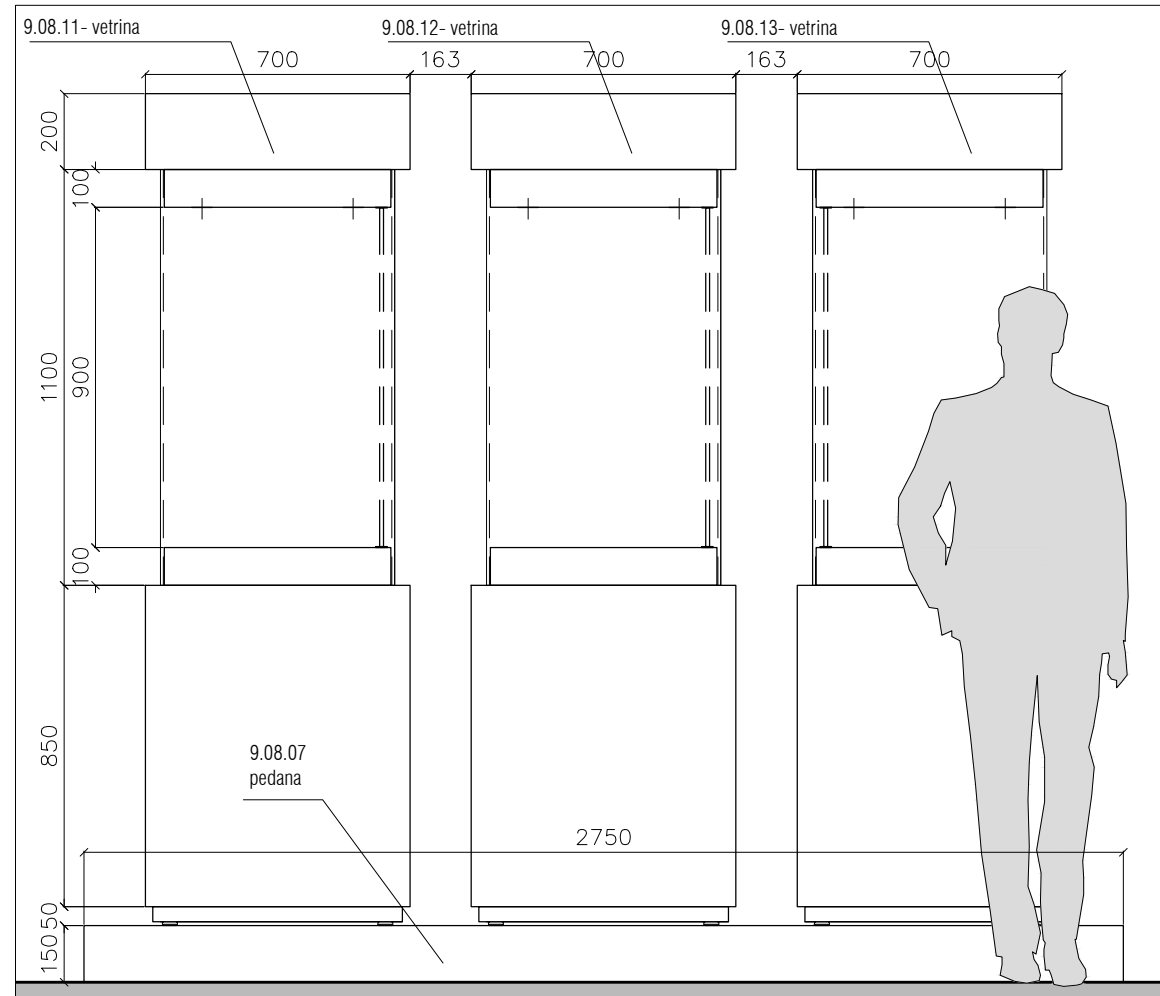

9.08.08 / 9.08.09 / 9.08.10
9.08.11 / 9.08.12 / 9.08.13 vetrine

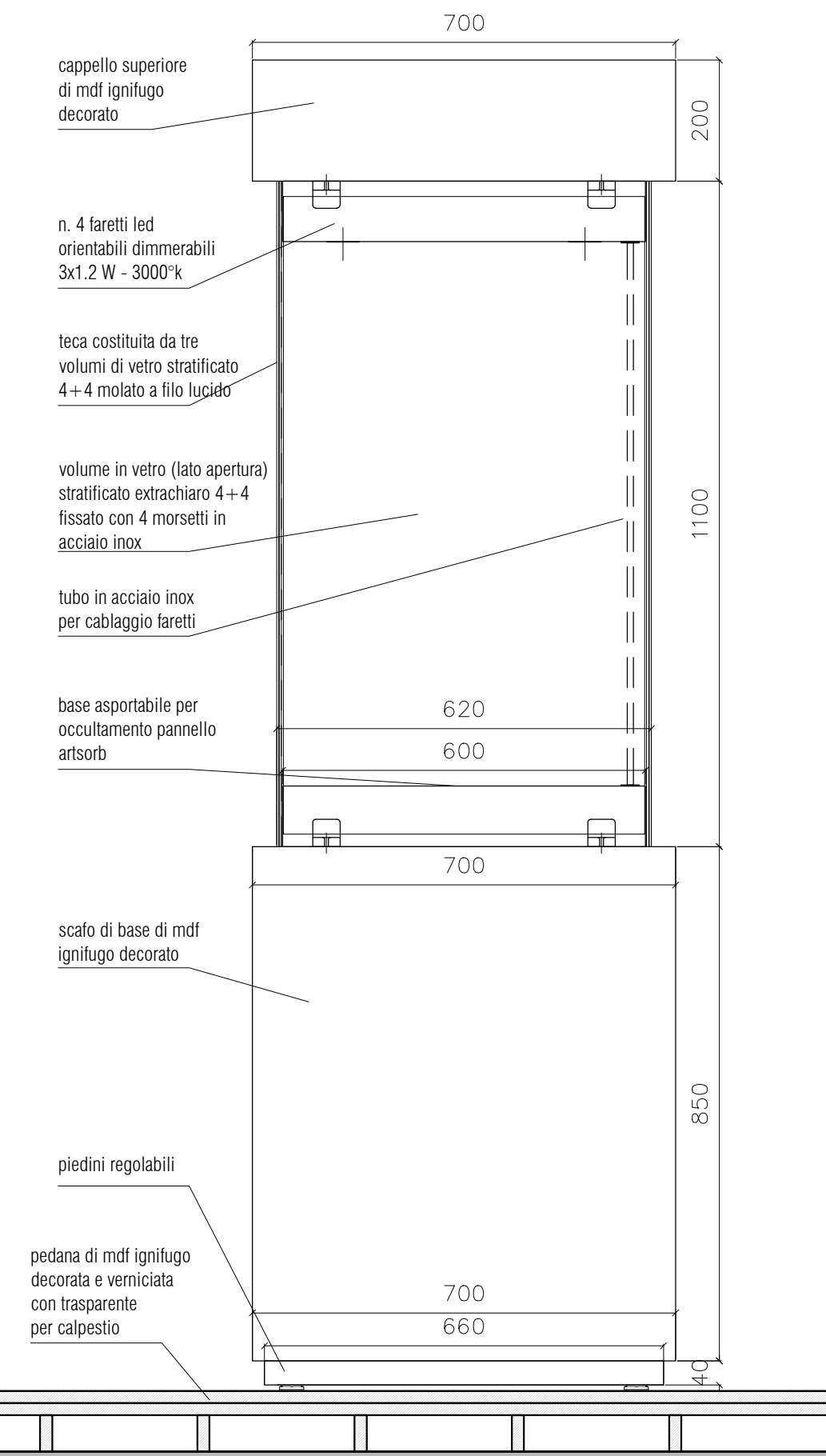
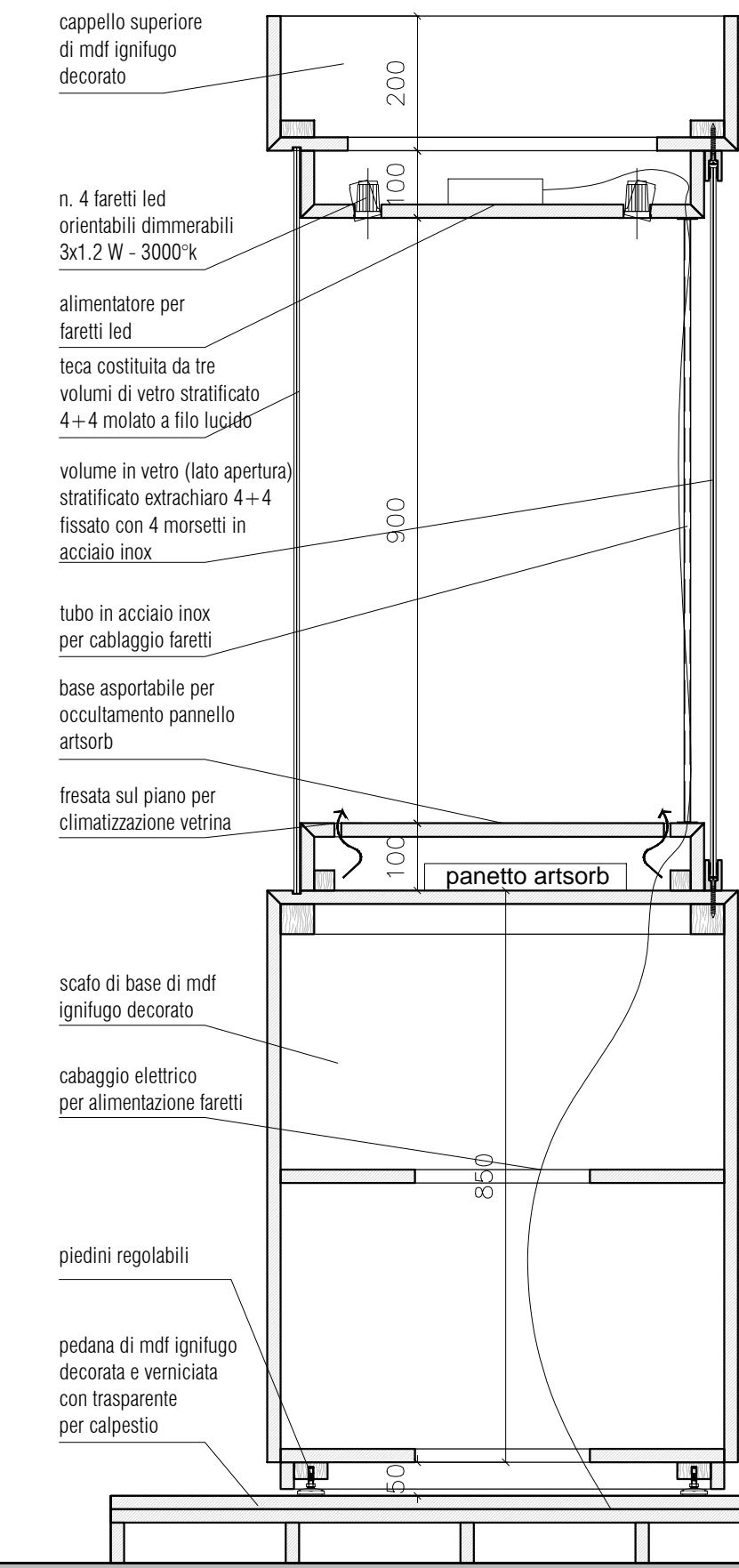

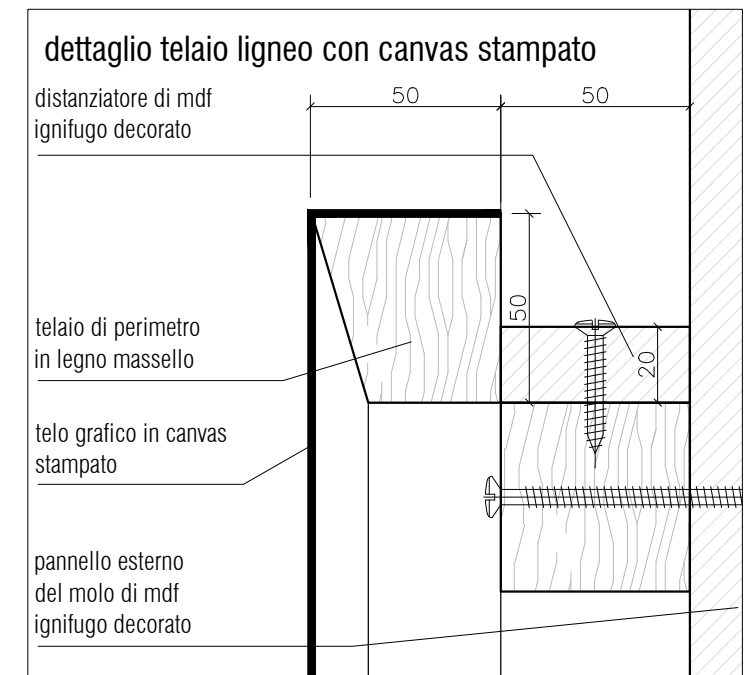
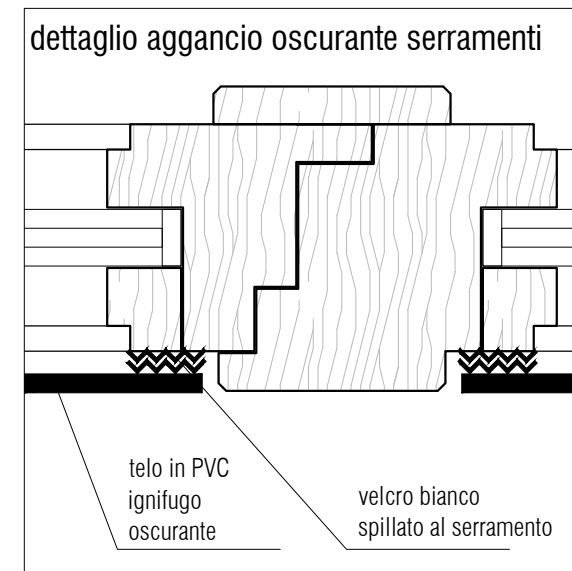
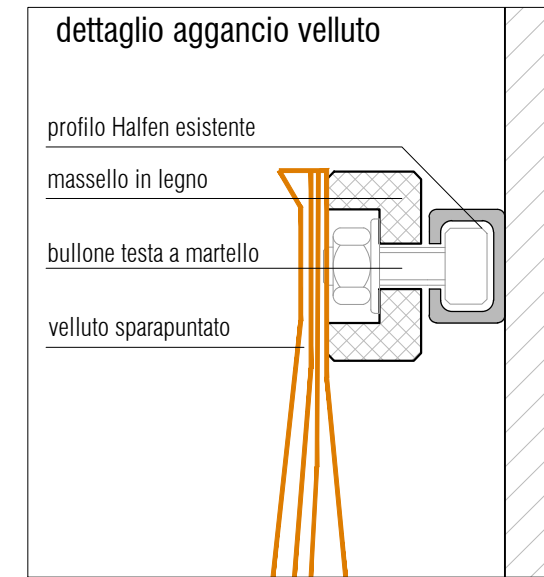
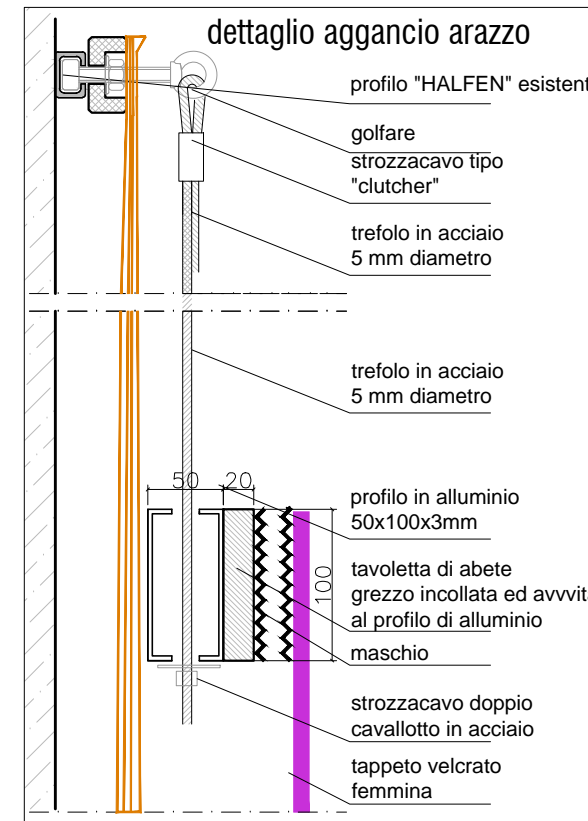
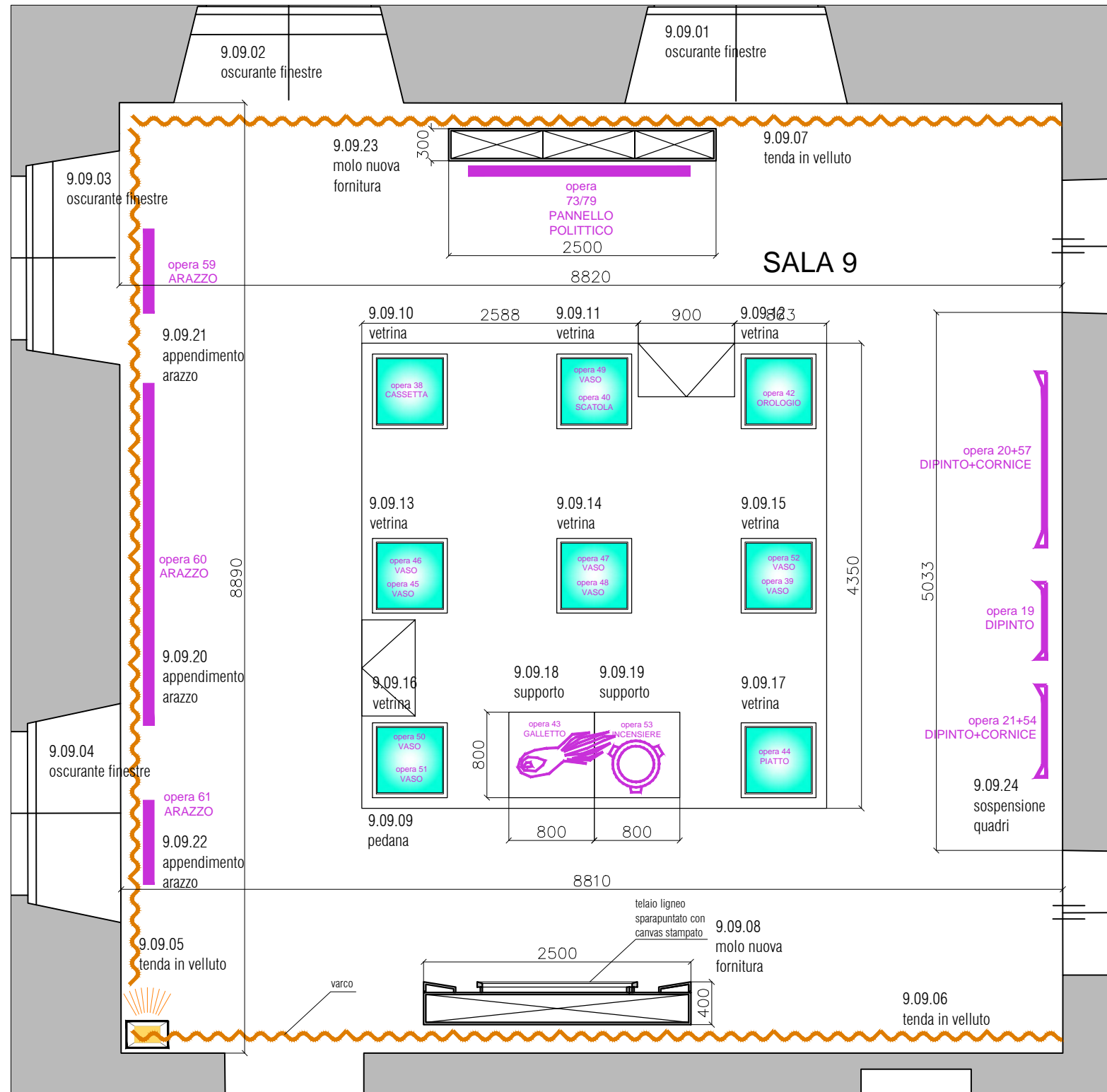

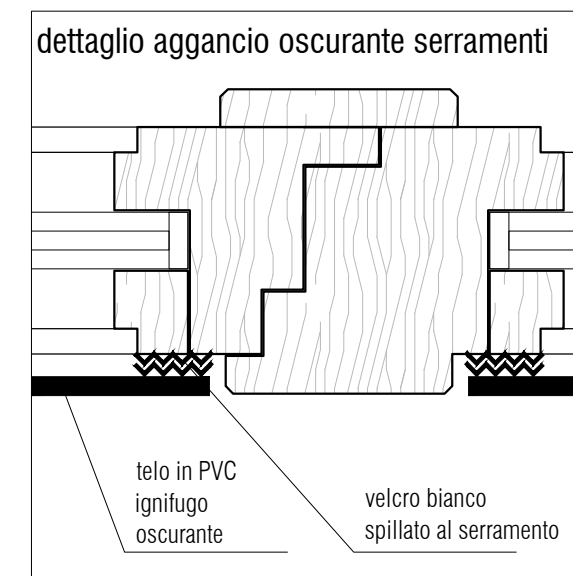
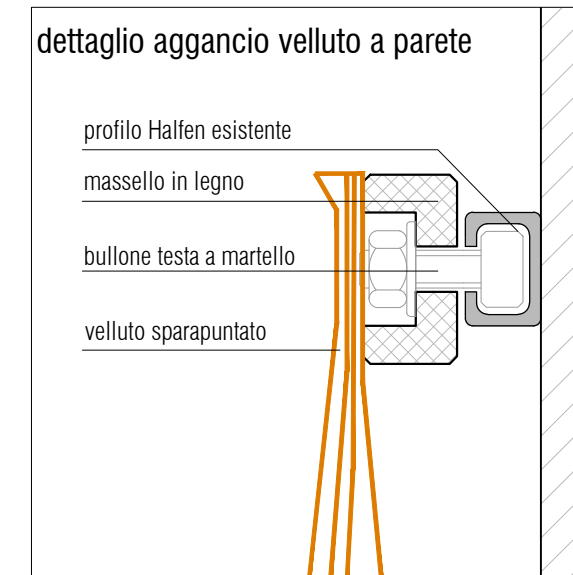
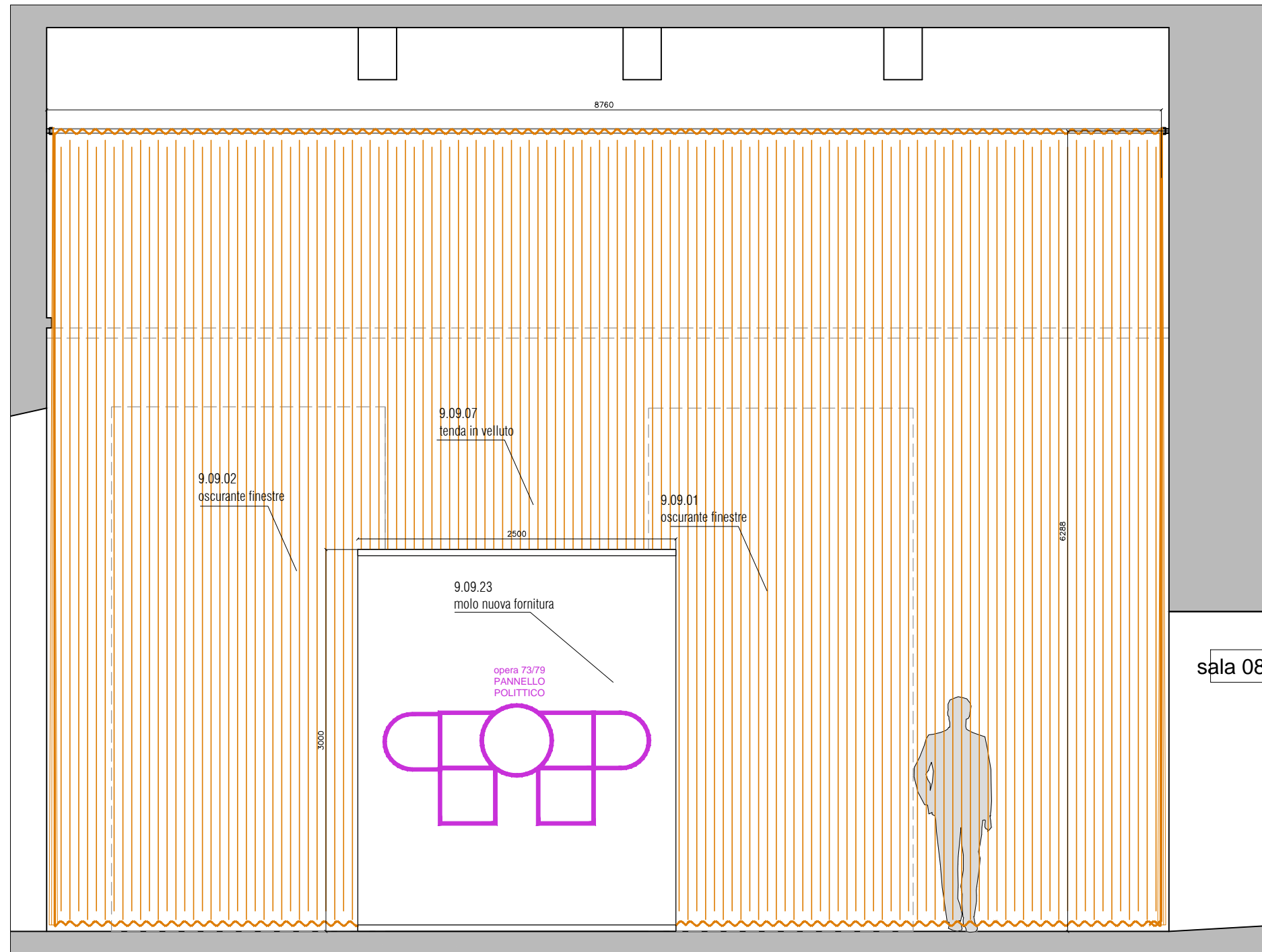

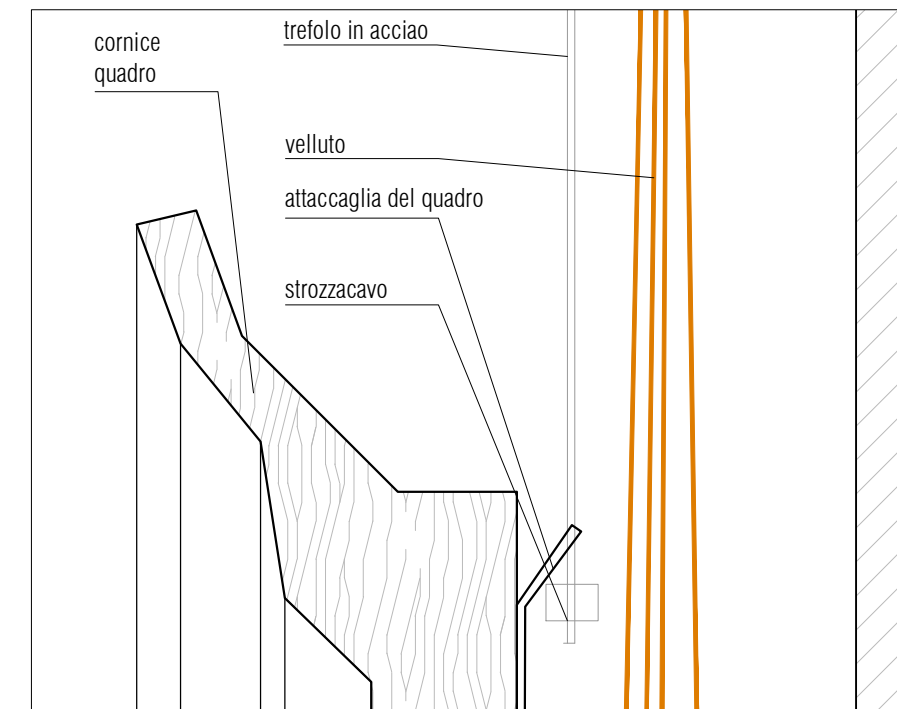
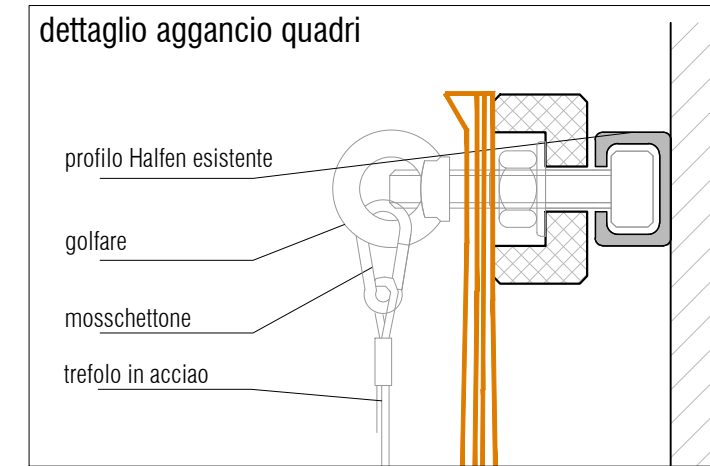
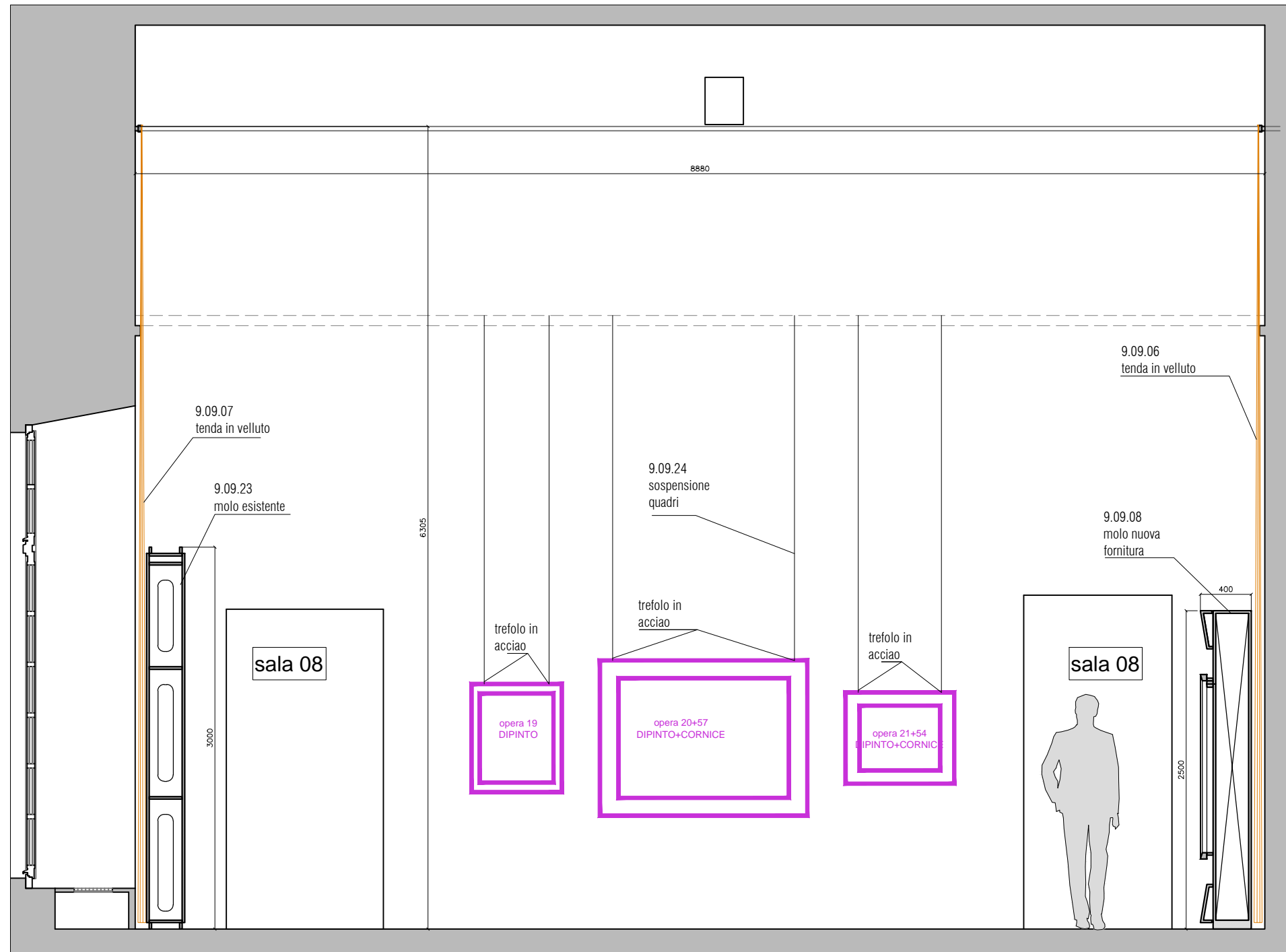

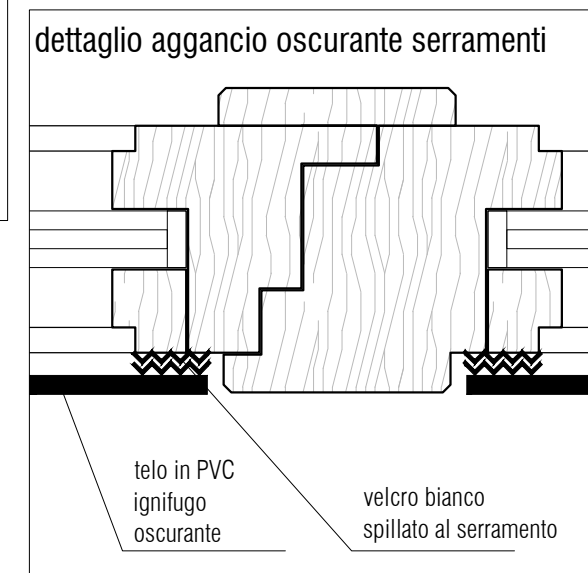
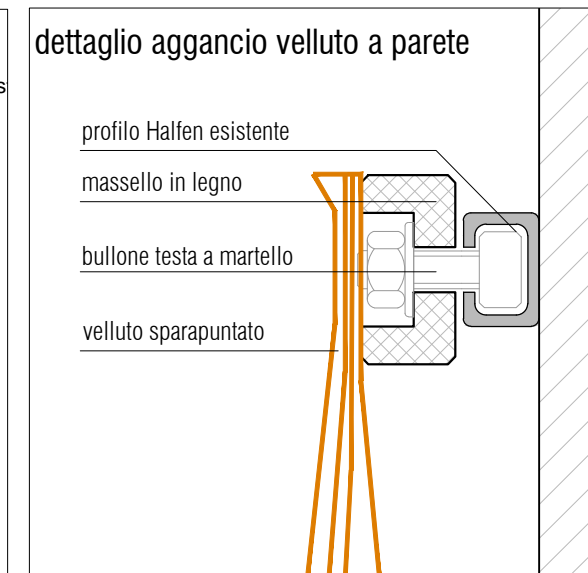
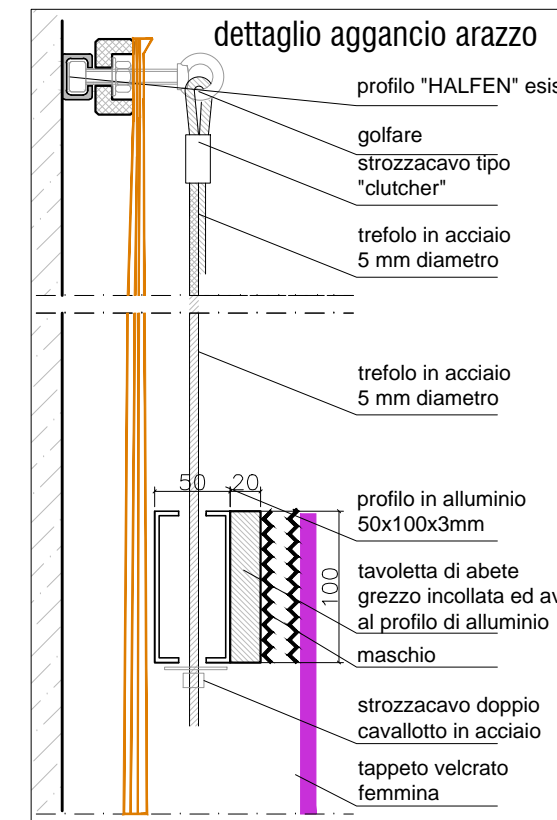
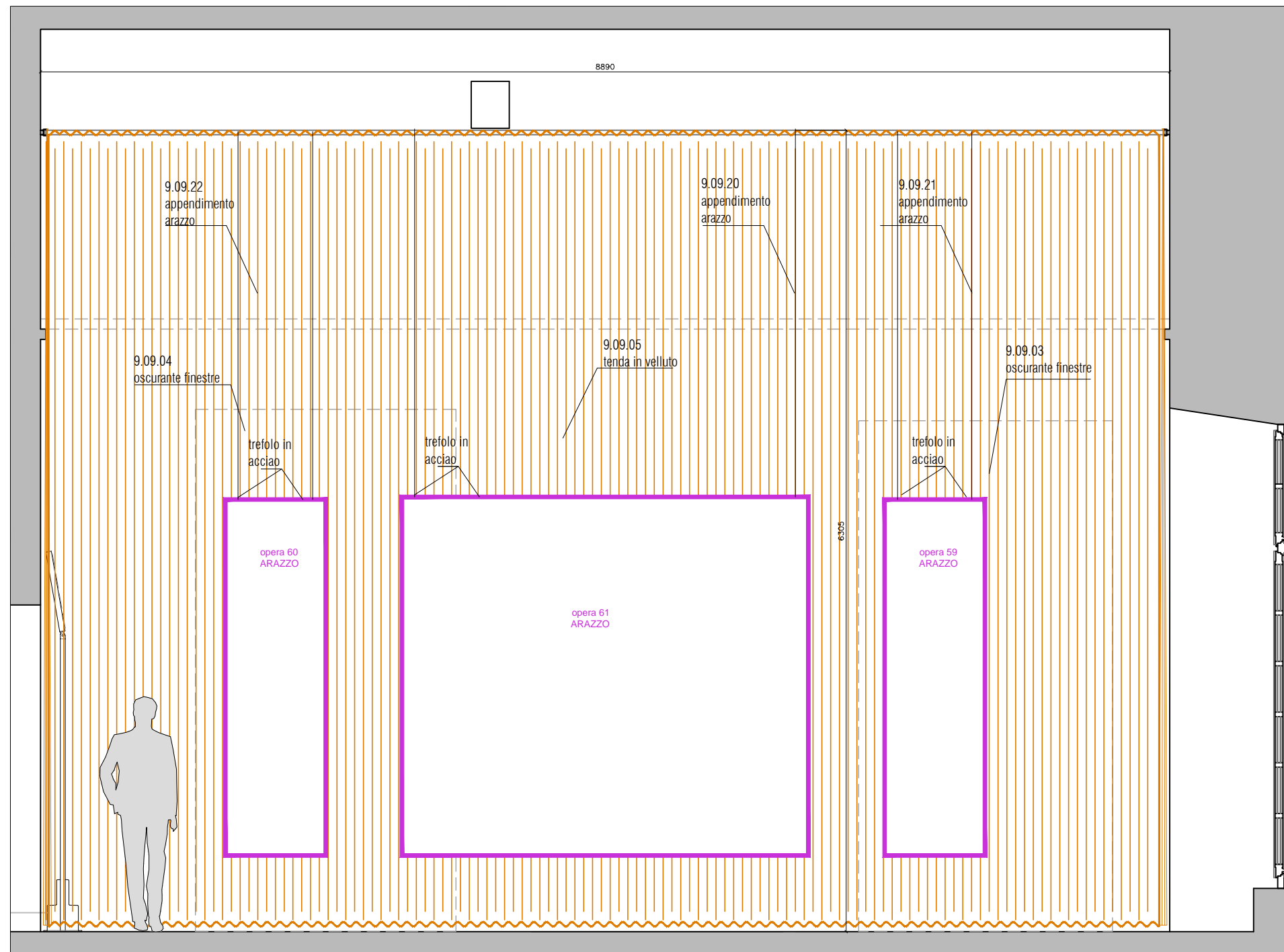

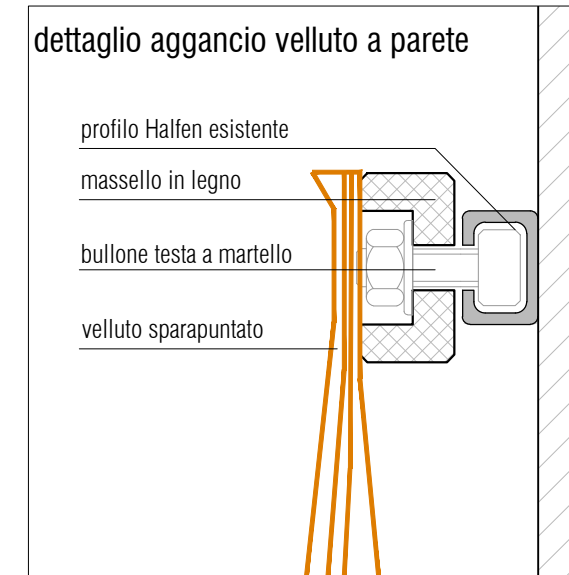
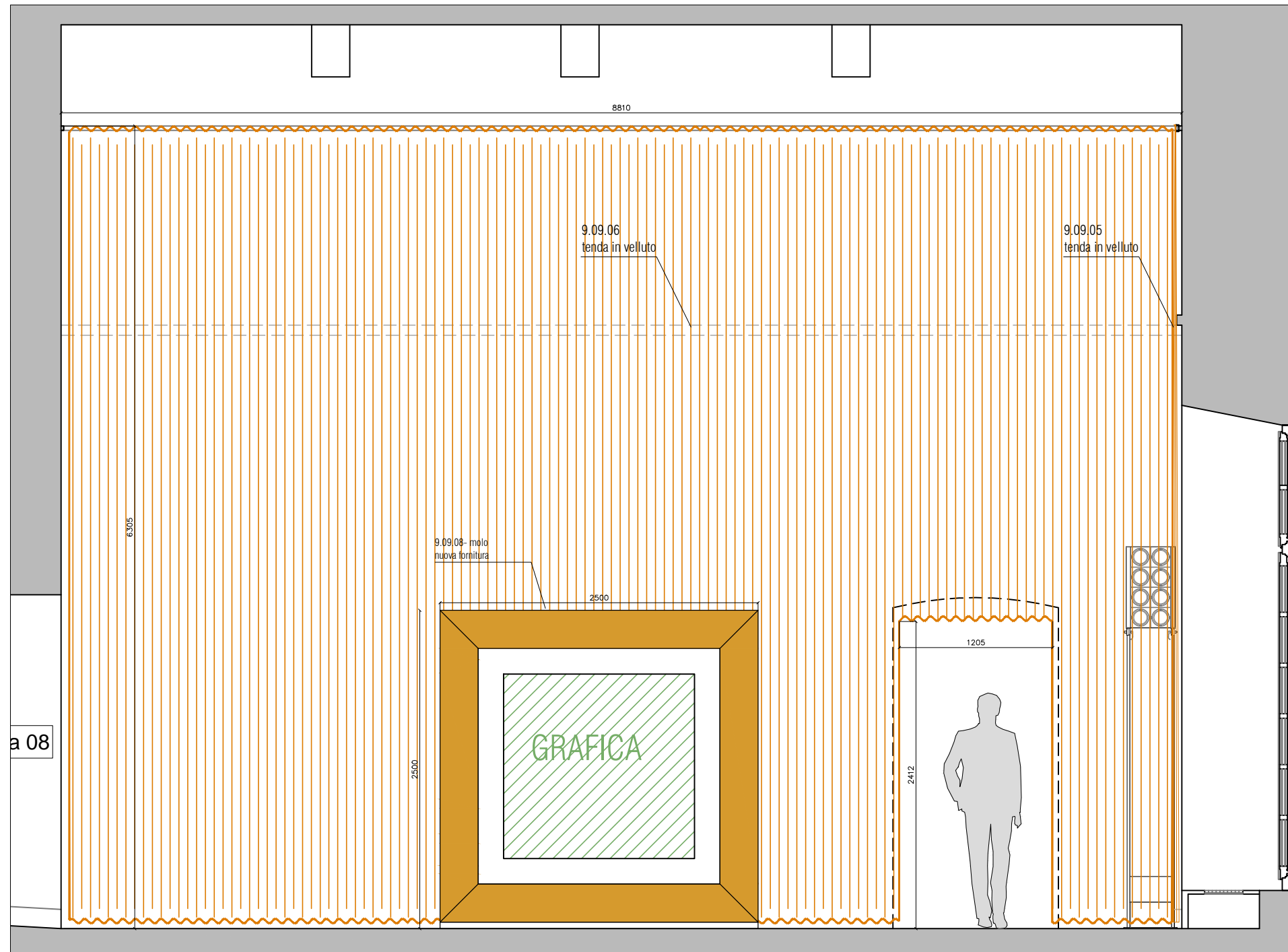

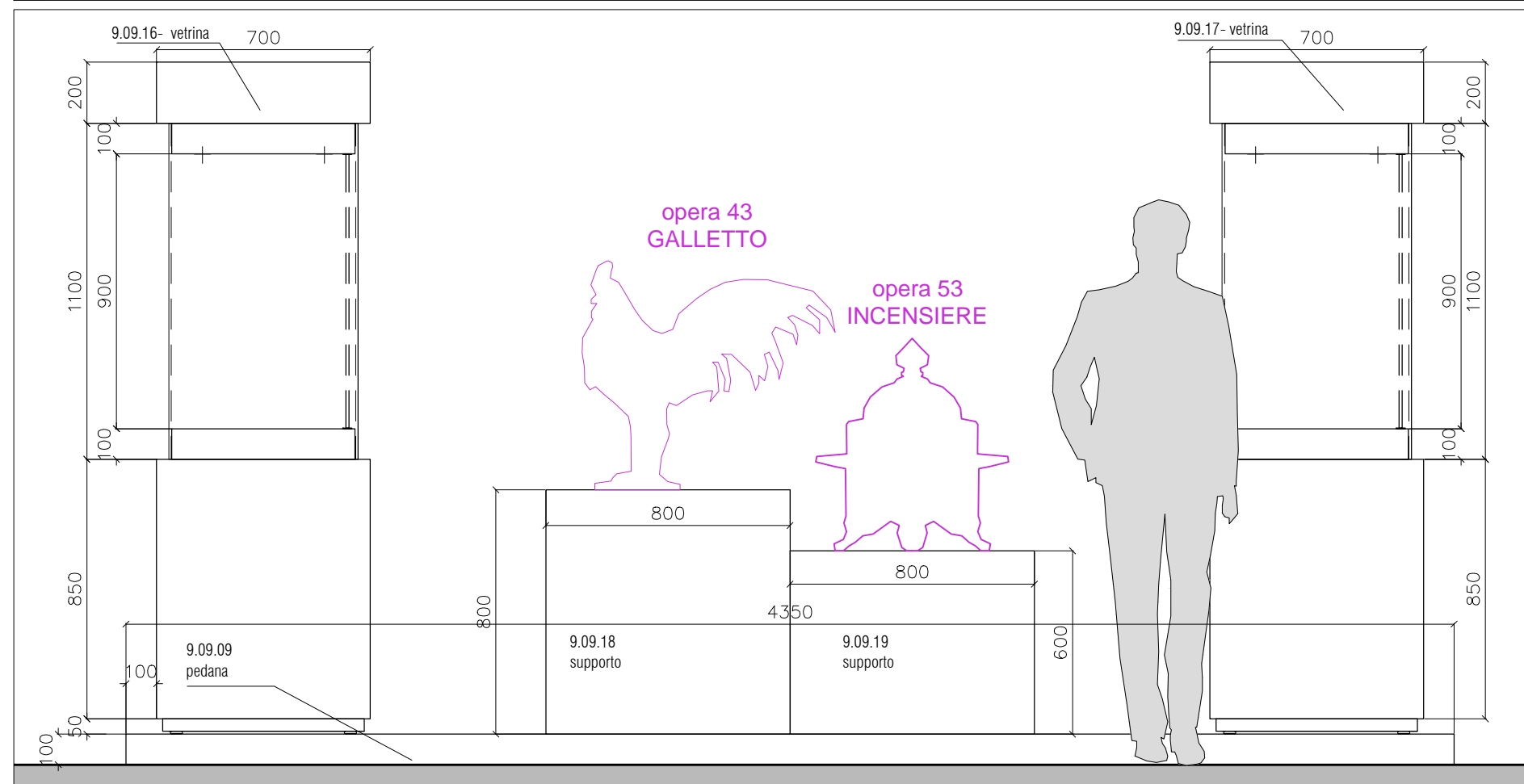
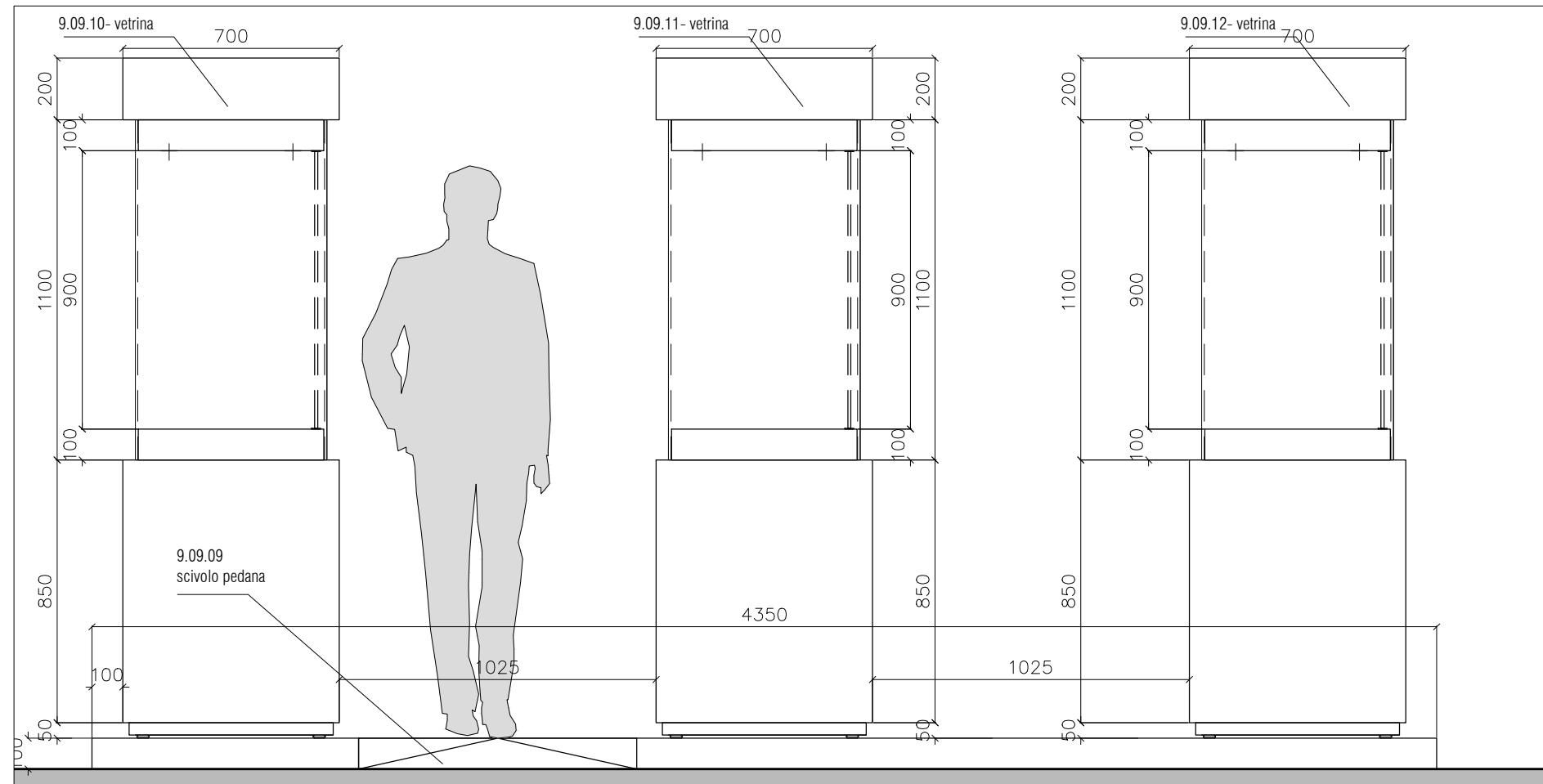

9.09.10 / 9.10.11 / 9.09.12 / 9.09.13 /
9.09.14 / 9.09.15 / 9.09.16 / 9.09.17 vetrine

